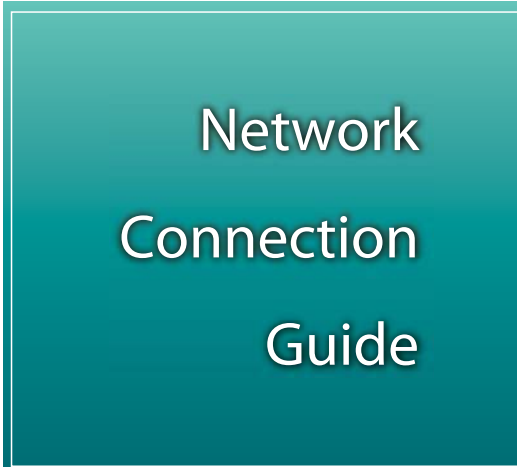

**Machine Automation Controller  
NJ Series**

**Serial (RS-232C) Communications  
Connection Guide**

**Smart Camera  
F430-F Series**

A teal-colored rectangular box with a thin white border is positioned on the right side of the page. It contains the text "Network Connection Guide" in white, centered vertically and horizontally.

**Network  
Connection  
Guide**

### **About Copyrights and Trademarks**

---

Screen shots of elements of Microsoft products are used with permission from Microsoft Corporation.

Windows is a registered trademark of Microsoft Corporation in the USA and other countries.

Sysmac and SYSMAC are trademarks or registered trademarks of OMRON Corporation in Japan and other countries for OMRON factory automation products.

Company names and product names in this document are the trademarks or registered trademarks of their respective companies.

---

## Contents

<b>1. Related Manuals .....</b>	<b>1</b>
<b>2. Terms and Definitions .....</b>	<b>2</b>
<b>3. Restrictions and Precautions .....</b>	<b>3</b>
<b>4. Overview .....</b>	<b>4</b>
<b>5. Applicable Devices and Device Configuration .....</b>	<b>5</b>
5.1. Applicable Devices .....	5
5.2. Device Configuration .....	6
<b>6. Serial Communication Settings .....</b>	<b>8</b>
6.1. Configuring the Serial Communication Settings .....	8
6.2. Cable Wiring Diagram .....	9
6.3. Communication Verification Example .....	11
<b>7. Steps for Connecting .....</b>	<b>12</b>
7.1. Operation Flow .....	12
7.2. Smart Camera Setup .....	14
7.3. Controller Setup .....	20
7.4. Confirm Serial Communications .....	40
<b>8. Initializing the System .....</b>	<b>46</b>
8.1. Initializing the Controller .....	46
8.2. Initializing the Smart camera .....	48
<b>9. Program .....</b>	<b>49</b>
9.1. Overview .....	49
9.2. Send/Receive Sequence .....	54
9.3. Error Judgment Processing .....	55
9.4. Variables Used .....	56
9.5. Functional Configuration of Program in ST Language .....	59
9.6. (Protocol Macro Data) .....	64
9.7. Timing Chart .....	71
9.8. Error Process .....	73
<b>10. Revision History .....</b>	<b>75</b>

# 1. Related Manuals

To ensure system safety, make sure to always read and follow the information provided in all Safety Precautions and Precautions for Safe Use in the manuals for each device which is used in the system.

The following Omron Corporation (hereinafter referred to as "Omron") manuals are related to this document:

Manual No.	Model	Manual Name
W500	NJ Series	NJ Series CPU Unit User's Hardware Manual
W501	NJ/NX Series	NJ/NX Series CPU Unit Software User's Manual
W336	CJ Series	CJ Series Serial Communications Unit User manual
W504	SYSMAC-SE2□□□	Sysmac Studio Version 1 Operation Manual
W502	NJ/NX Series	NJ/NX Series Instructions Reference Manual
Z433	F430-F Series	Smart Camera F430-F Series User Manual
Z444	F430-F Series	Smart Camera F430-F Series User Manual for Communications Settings

## 2. Terms and Definitions

Term	Description / Definition
Protocol Macro	This function enables data Send / Receive with general-purpose external devices by storing the data Send / Receive procedure (Protocol) used with the general-purpose external devices in the Serial Communication Board or Unit and executing the PMCR instruction in the CPU unit.
Protocol	The unit that comprises an independent communication processing for a specific general-purpose external device as a data Send / Receive procedure is called a "Protocol". A "Protocol" consists of multiple "Sequences".
Sequence	A unit of independent communication processing that can be activated from the PMCR instruction on the ladder program. The activated sequence sequentially executes the steps included in it.
Step	A unit of data to execute any Message or other Send / Receive process, Receive Buffer Clear, and Step Waiting process. A maximum of 15 Steps can be set for 1 Sequence.
Send Message	A communication frame (Command) sent to a general-purpose external device. It is called from a Step in the sequence and sent to a general-purpose external device.
Receive Message	A communication Frame (Response) sent from a general-purpose external device. It is called from a Step in the sequence and compared with the data received from the general-purpose external device.
Receive Matrix	The Receive Matrix is used when it is not possible to identify only one communication frame (response) sent from a general-purpose external device. It is possible to register multiple communication frames in the Receive Matrix.
Case	A unit to register multiple communication frames (responses) in the receive matrix. 1 communication frame is registered as 1 case. It is possible to register a maximum of 15 case types in the Receive Matrix.

## 3. Restrictions and Precautions

- (1) Understand the specifications of devices which are used in the system. Allow some margin for ratings and performance.
- (2) Provide safety measures, such as installing a safety circuit, in order to ensure safety and minimize the risk of abnormal occurrence.
- (3) To ensure system safety, make sure to always read and follow the information provided in all Safety Precautions and Precautions for Safe Use in the manuals for each device which is used in the system. The user is encouraged to confirm the standards and regulations that the system must conform to.
- (4) It is prohibited to copy, to reproduce, and to distribute a part or the whole of this document without the permission of OMRON Corporation.
- (5) The information contained in this document is current as of January 2020.  
It is subject to change for improvement without notice.

The following notations are used in this document.

 <b>WARNING</b>	Indicates a potentially hazardous situation which, if not avoided, may result in minor or moderate injury, or may result in serious injury or death. Additionally, there may be severe property damage.
---	---

 <b>CAUTION</b>	Indicates a potentially hazardous situation which, if not avoided, may result in minor or moderate injury, or property damage.
--	--



### **Precautions for Safe Use**

---

Precautions on what to do and what to avoid doing to ensure the safe use of the product.

---



### **Precautions for Correct Use**

---

Precautions on what to do and what not to do to ensure proper operation and performance.

---



### **Note**

---

Additional information to read as required.

This information is provided to increase understanding and make operation easier.

---

### **Symbols**

---



- This indicates operations that you must do.  
The specific operation is shown in the circle and explained in text.
-

---

This example shows a general precaution for something that you must do.

---

## 4. Overview

This document describes the procedures for connecting the Omron smart camera (F430-F Series) to the NJ Series Machine Automation Controller (hereinafter referred to as Controller) via serial communications and for verifying the serial connection.

Refer to Section 6. EtherNet/IP Settings and Section 7. EtherNet/IP Connection Procedure to understand setting methods and key points for setting up Serial Communications.

Using the user program in the "CX-Programmer Project File" and the protocol data in the "CX-Protocol Project File" prepared in advance, use the "Measurement trigger" command for the smart camera to check the serial communication connection.

Obtain the Sysmac Studio project file in advance before proceeding. Contact Omron for information on how to obtain this file.

Name	Filename	Version
Sysmac Studio Project File (Extension: smc2)	OMRON_F430_NJ_PMCR232C_V100.smc2	Ver.1.00
CX-Protocol Project File (extension: psw)	OMRON_F430_NJ_PMCR232C_V100.psw	Ver.1.00



The purpose of this document is to explain the wiring method, the communication settings required for connection of the devices and the step by step setting procedure. The program included with the document was created using the same procedures and can be used to confirm that all the settings have been made correctly and that a connection can be established (Confirm Connection). It is not a program created on the premise of constant use in the field, so its functionality and performance aspects have not been fully considered. When building an actual system, it is necessary to refer to the wiring method and communication setting contents and setting procedures described in this document, and to design a new program according to the customer's purpose for the program.



## 5. Applicable Devices and Device Configuration

### 5.1. Applicable Devices

The devices for which connection is supported and guaranteed are as follows.

Manufacturer	Name	Model	Version
OMRON	NJ Series CPU Unit	NJ501-1500 NJ501-1400 NJ501-1300 NJ301-□□□□	Same or higher version as indicated in section 5.2.
OMRON	Serial Communications Unit	CJ1W-SCU□1-V1 CJ1W-SCU□2	
OMRON	Smart camera	F430-F□□□□□□□-□□□	



#### Note

In this document, from among the above target devices, connection confirmation is performed using the devices listed in section 5.2. When using a device that is not described in section 5.2. Among the above target devices, check the connection referring to the contents of this document.



#### Note

This document describes the procedure for establishing the communication connection of the device, and does not describe the operation, installation and wiring method of the device. For detailed information on the above products (other than communication connection procedure), please refer to the instruction manual of the product or contact OMRON.



#### Precautions for Correct Use

In this document, the devices with models and versions listed in section 5.2.

You cannot use devices with versions lower than the versions listed in section 5.2.

To use the above devices with models not listed in 5.2. or versions higher than those listed in 5.2., check the differences in the specifications by referring to the manuals before operating the devices.



## 5.2. Device Configuration

The system components required for reproducing the connection procedures described in this document are as follows.

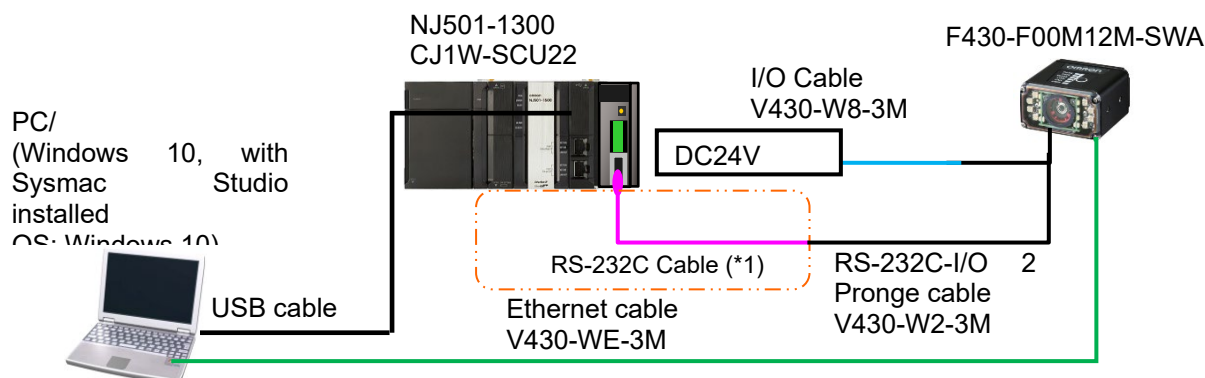

Manufacturer	Name	Model	Version
OMRON	NJ Series CPU Unit (Built-in EtherNet/IP Port)	NJ501-1300	Ver.1.15
OMRON	Power Supply Unit	NJ-PA3001	
OMRON	Serial Communications Unit	CJ1W-SCU22	Ver.2.1
OMRON	Sysmac Studio	SYSMAC-SE2□□□	Ver.1.29
OMRON	Sysmac Studio Project File	OMRON_NJ_F430_PMC R232C_V100.smc2	Ver.1.00
OMRON	CX-Protocol Project File	OMRON_NJ_F430_PMC R_V100.psw	Ver.1.00
-	Computer (OS: Windows 10)	-	
-	USB cable (USB 2.0-compliant B-type connector)	-	
OMRON	Smart camera	F430-F00M12M-SWA	Ver.5.2.0
OMRON	RS-232C-I/O 2 Prong cable	V430-W2-3M	
OMRON	I/O cable	V430-W8-3M	
OMRON	Ethernet Cable (*1)	V430-WE-3M	
	RS-232C Cable (*2)		
	DC24V Power Supply		

\*1: The Ethernet cable is used for the connection to the PC running the AutoVision software.

\*2: Please refer to section 6.2 RS-232C Cable wiring diagram.



### Precautions for Correct Use

Please prepare the latest file of "Sysmac Studio project file" from Omron Corp. beforehand.  
(Contact Omron for information on how to obtain these files.)



### Precautions for Correct Use

Use the Auto Update tool to update Sysmac Studio and CX-Protocol software to the version indicated in this document (or higher). If you use a version other than the version specified in this section, there may be differences in the procedures in Chapter 7 and after. In this case, please refer to "Sysmac Studio Version 1 Operation Manual (W504)" or "CX-Protocol

---

Operation Manual" (W344) for additional procedures to follow.

---



**Note**

If the device configuration or versions are different, it may not be reproducible. After confirming the configuration, models and versions, if it is different from your configuration, please contact Omron.

---



**Note**

In this document, a USB connection is described. For information on how to install the USB driver, refer to A-1 Driver Installation for Direct USB Cable Connection in Appendices of the Sysmac Studio Version 1 Operation Manual (Cat. No. W504).

---



**Note**

Refer to the "Smart Camera F430-F Series User Manual" (Z433) for the power supply specifications that can be used for DC24V power supply (for Smart camera).

---

## 6. Serial Communication Settings

An explanation of the communication parameter specifications and cable wiring.



### Note

If you wish to use communication settings other than those described in this chapter, you must also change the program used. For more information on the program, please refer to "9. Program".

### 6.1. Configuring the Serial Communication Settings

The Following are the Serial Communication Settings.

Parameter (Setting)	SCU Unit *	Smart camera
Unit Number	0	-
Connection Port	Port 2 (RS-232C)	-
Serial Communication Mode	Protocol Macro	-
Data Bits	8 bit	8 bit (default)
Stop Bits	1 bit	1 bit (default)
Parity	No	None (Default)
Baud Rate	115,200bps	115,200Bps (default)
Protocol macro transmission method	Full Duplex	-
Header	-	None (default)
Footer	-	<CR+LF>

\* SCU Unit: Serial Communications Unit



### Precautions for Correct Use

It is assumed that the serial communication unit used is "CJ1W-SCU22", the unit number is "0", the communication (connection) port is "port 2" and these have been set ahead of time. When connecting under conditions other than this, refer to Section 9 "Program" and change the control data of the assigned Relay Area and PMCR Instruction to create a program.

## 6.2. Cable Wiring Diagram

For details on cable wiring, refer to "Chapter 3 Installation and Connection" of "CJ Series Serial Communication Board / Unit User's Manual" (W336).

Check the connector shape and signal line (pin assignment) before creating a cable.

### ■ Connector Type and Signal Wires (Pin Assignments)

<CJ1W-SCU22> Applicable connector: D-SUB 9 Pin (CJ1W-SCU22 side connector shape: female)

ピン No.	略称	信号名称	入出力
1	FG	シールド	—
2	SD	送信データ	出力
3	RD	受信データ	入力
4	RS	送信要求	出力
5	CS	送信可	入力
6	5V	電源	—
7	DR	データセットレディ	入力
8	ER	データターミナルレディ	出力
9	SG	信号用接地	—
シエル	FG	シールド	—

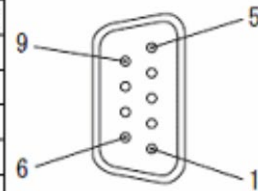

<V430-W2-3M> Applicable connector: D-SUB 9 Pin (V430-W2-3M side connector shape: female)

ピン番号	信号名	ピン配置図
1	-	
2	HOST_RxD	
3	HOST_TxD	
4	-	
5	0V	
6	-	
7	-	
8	-	
9	-	

■ RS-232C Cable / Pin Layout

Create the RS-232C cable referring to the following wiring.

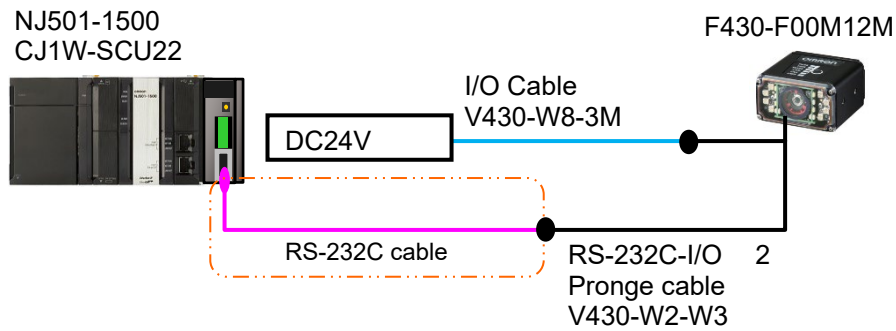
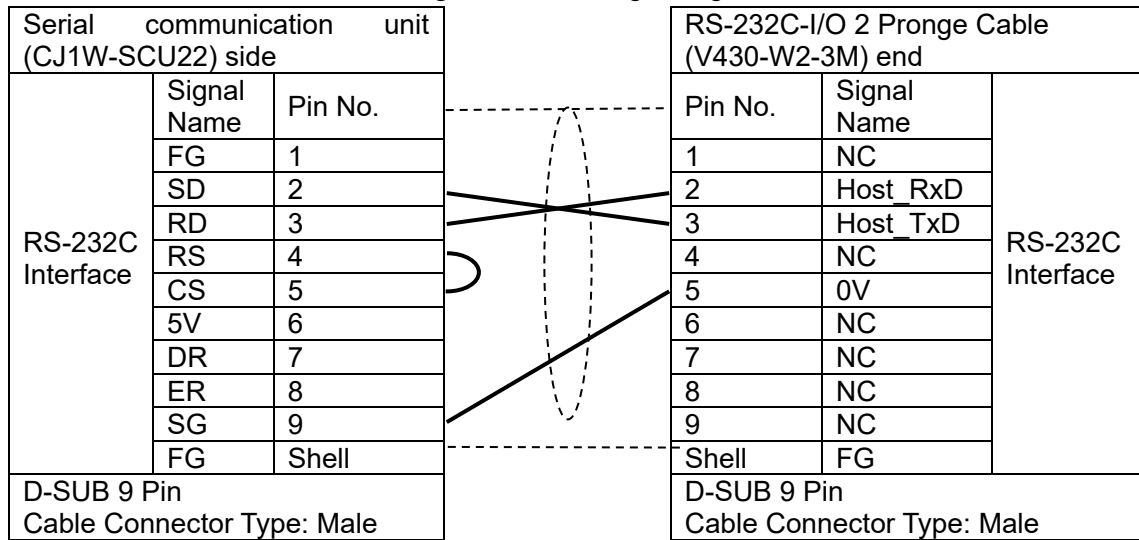

### 6.3. Communication Verification Example

The example used in this document, is the case where a program is sent and received from the controller to the smart camera using a program in structured text (ST) language and Protocol Macro data.

The controller and smart camera send and receive the message "Inspection trigger (Sequence No.900)". An Overview of the Sequence Operation

- Sequence Operation Overview

- ① Execute a protocol macro instruction (ExecPMCR instruction) specifying sequence No. 900 of protocol macro data in the ST language program.
- ② "Serial trigger" command of Sequence No. 900 is selected from Protocol Macro data and sent to the smart camera
- ③ Execute command with smart camera according to the data sent from the controller.
- ④ The result of the command executed by the smart camera is received by the controller and stored in the specified variable

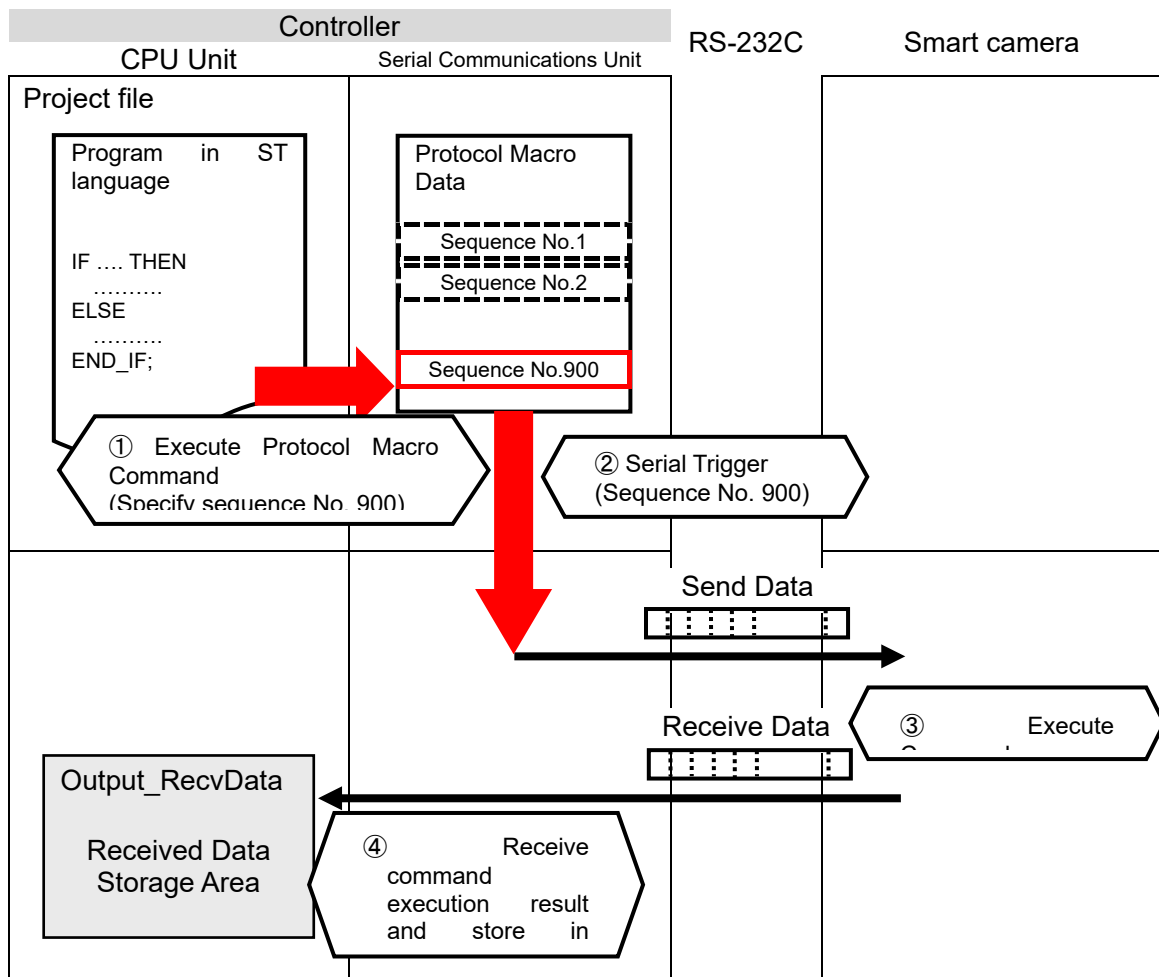

## 7. Steps for Connecting

This section describes the procedures for connecting the Smart camera and Controller by serial communications.

The explanations of procedures for setting up the PLC and smart camera given in this document are based on the use of the factory default settings. If initialization is required, refer to Section 8. Initialization Method.

### 7.1. Operation Flow

Use the following procedures to set up a Serial connection on the controller (PLC).

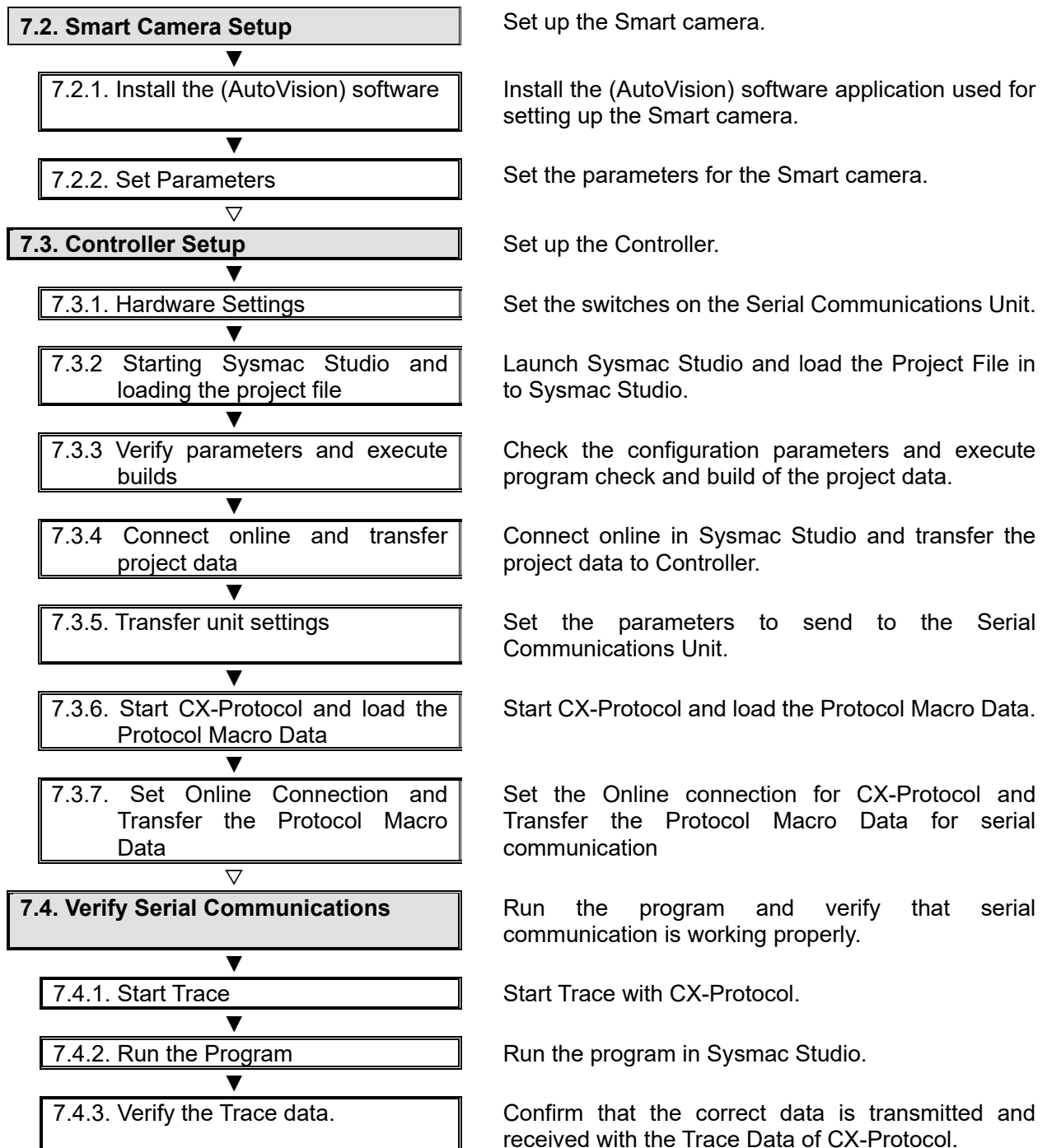



#### 7.4.4. Verify the Receive Data

In Sysmac Studio, check that the correct data is written to the controller variable.



## 7.2. Smart Camera Setup

Set up the Smart camera.



### Precautions for Correct Use

Use a PC (personal computer) to set the parameters for the smart camera.

Note that there may be some changes required for the PC settings depending on the current state of PC.

#### 7.2.1. Install the (AutoVision) software

Install the (AutoVision) software application used for setting up the Smart camera. For more details on installing the Autovision software, please refer to the "AutoVision Quick Start Guide" (Z434).

#### 7.2.2. Set Parameters

Set the parameters for the Smart camera.

Set the IP address of your computer to "192.168.188.100" and its subnet mask to "255.255.0.0".

- 1 Connect the RS-232C-I/O 2 Pronge cable (V430-W2-3M) to the I/O Connector. Then connect the V430-W2-3M I/O connector side to I/O cable V430-W8-3M.

Connect the 24V and 0V wires of V430-W8-3M to the 24 VDC power supply.

\* In this document, only the power supply line of the I/O cable is connected and connection confirmed. Be careful not to short-circuit any other wires.

\* Ground the shielded wire as needed. For more information on Grounding, please refer to the "Smart Camera F430-F Series User Manual" (Z433) - "2-7 Grounding and Power"

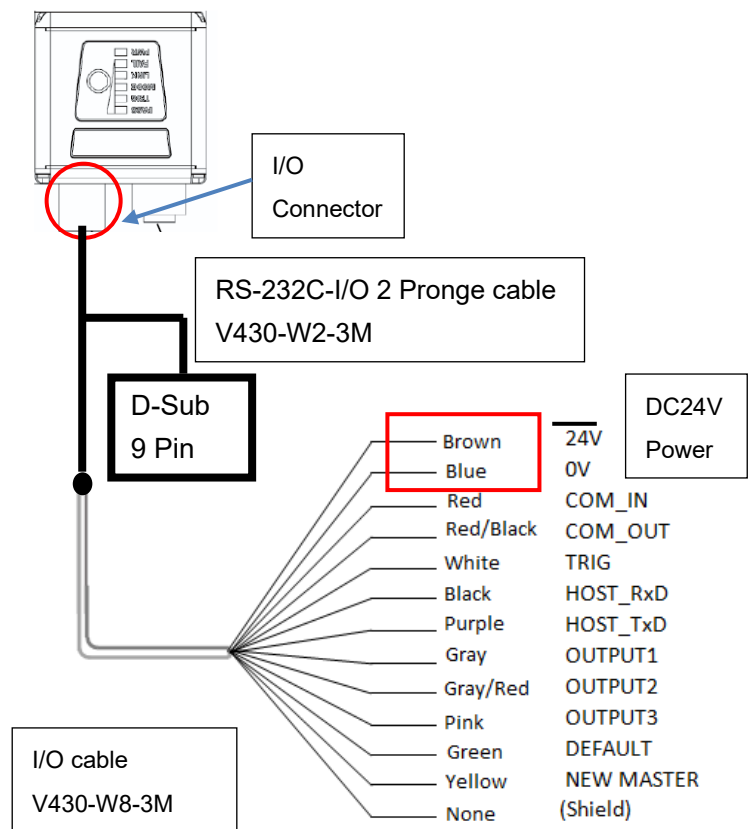

2 Connect the Ethernet connector on the smart camera to the PC using the Ethernet cable V430-WE-2M.

Turn ON the DC24V power supply.

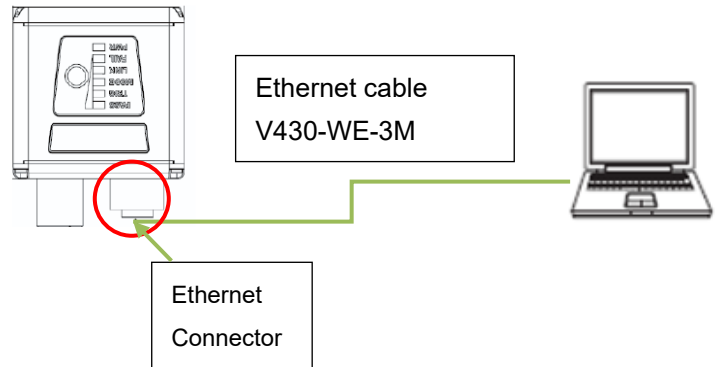

3 Set the IP Address of the PC.  
Set the IP Address to "192.168.188.100"  
set the subnet mask to "255.255.0.0".

Refer to Step 4 for the procedure to open the dialog on the right on a Windows 7 system.

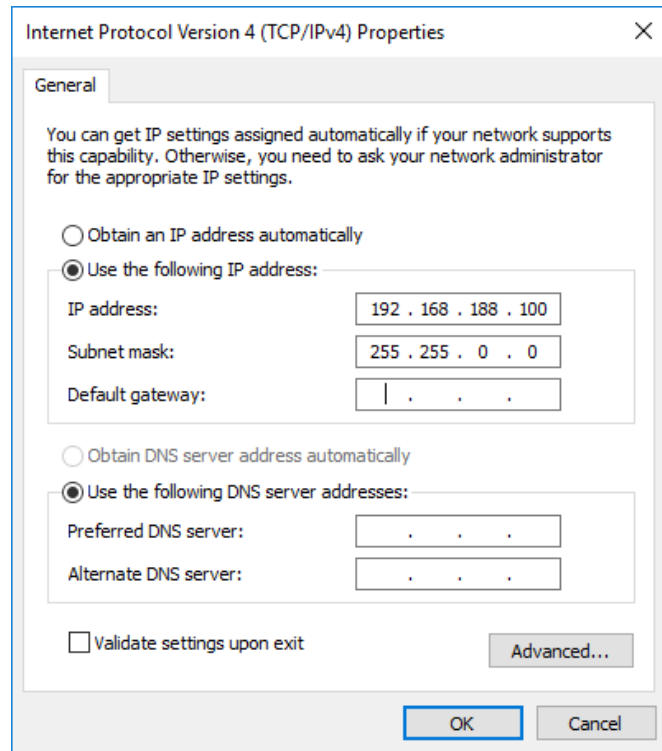

4 (1) From the Windows Start menu, select Control Panel - Network and Internet - Network and Sharing Center.  
(2) Click on Local Area Connection. The Local Area Connection Status Dialog Box is displayed. Click Properties.  
(3) In the [Local Area Connection Properties] dialog box, select [Internet Protocol Version 4 (TCP / IPv4)], and click the [Properties] button.  
(4) Click the "OK" button

5 Launch the AutoVision software.

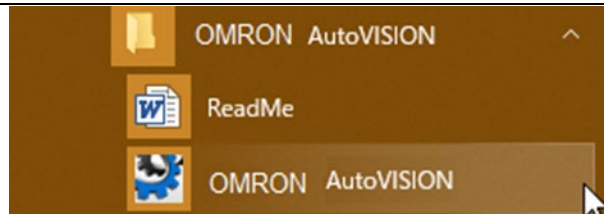

6 After starting Autovision, if the smart camera is displayed in the device selection list, proceed to Step 8.

If the AutoVision startup screen does not appear, go to step 7.

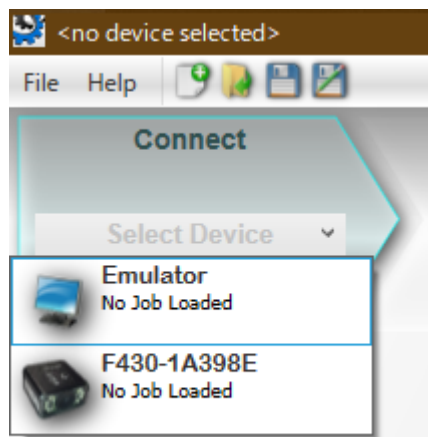

7 If the AutoVision startup screen does not appear, it means that communication between the smart camera and the PC has not been established so please check the following.

- Does the F430 and the PC have a proper physical (cable) connection?
- Are the respective IP Addresses on the PC and on the F430 Smart Camera set correctly?  
→ Refer to 4. for setting the IP Address of the PC.
- Do a hardware reset of the F430.  
→ When turning the power on, press and hold the setup button on the Smart Camera body until its light turns on.

8 After selecting the smart camera, the settings screen will display.

Check the settings indicated by the red boxes.

Some are the default settings and do not need to be changed.  
Serial port: RS232C-1  
Baud Rate: 115200  
Data bit: 8  
Parity: None  
Stop Bit: 1  
Flow control: None

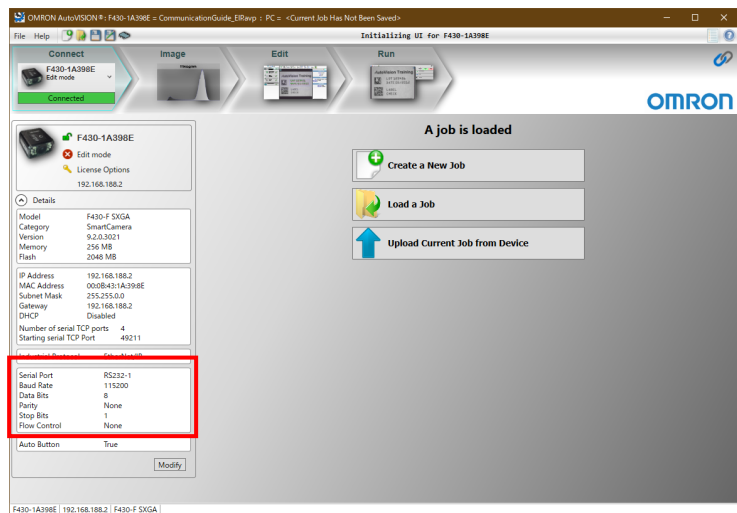

9 Create a new job and set the "Locate Shape", "OCR" and "Decode" tools.

\* In this chapter, you will create a job to output the detection points from the Locate Shape tool, the text string read by the OCR tool and character text decoded from a 2D Code using Serial (RS232C) communications.

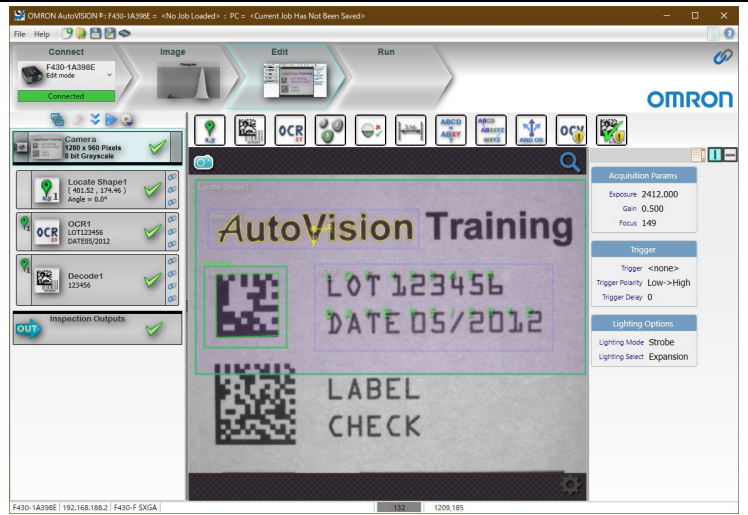

10 Select the camera tool and set the trigger to "Serial Trigger," "RS232C-1," "T".

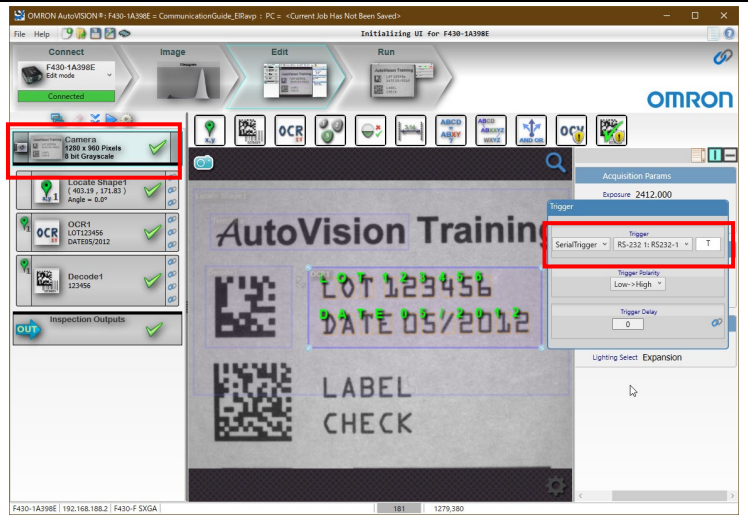

11 Click on Inspection Outputs and in its menu select "TCP/IP and Serial Out".

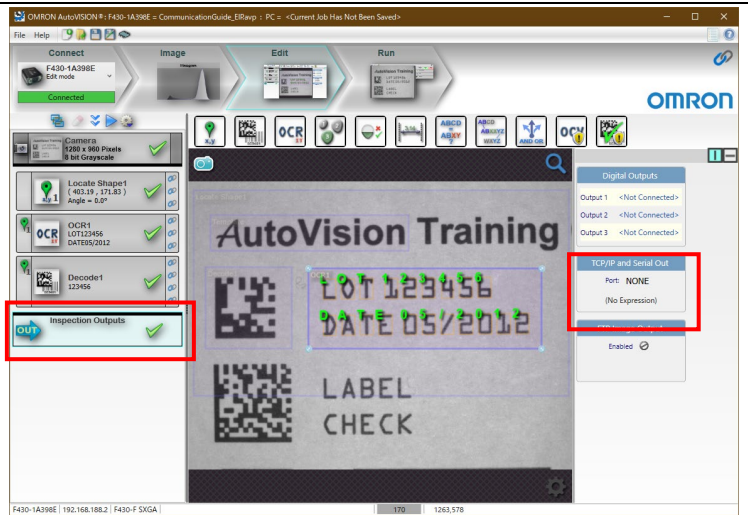

12 In the popup dialog, set "Character output port" to "RS232C-1"

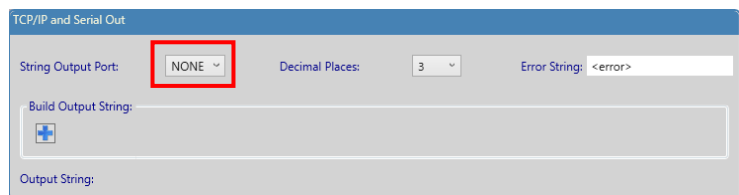



13 Click the  icon in the Output String and select Output Value.

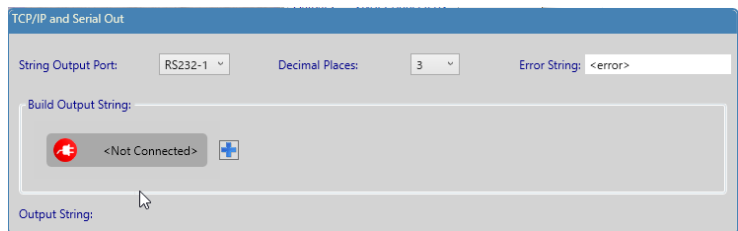

14 Click the icon in the red frame and select the data to output.

Here, select the location from "Locate Shape".

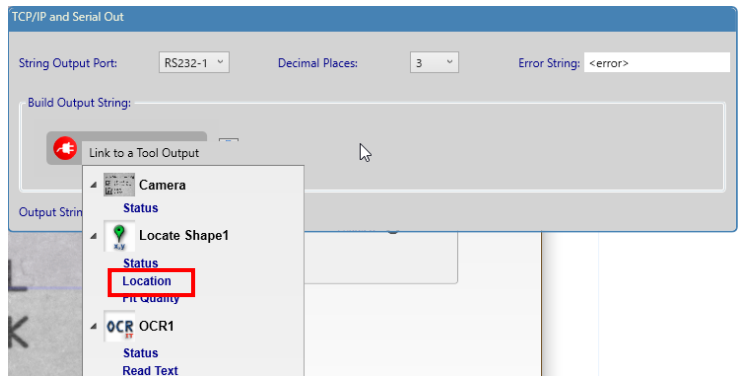
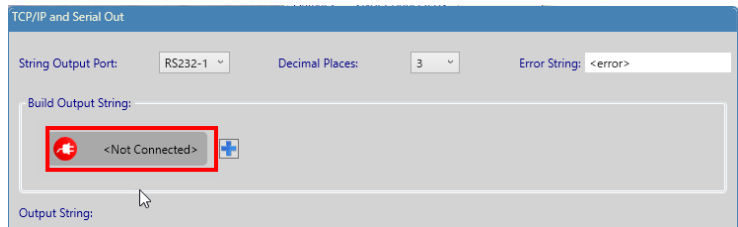

When selected, the current value is displayed in the "Output String" part of the red frame.



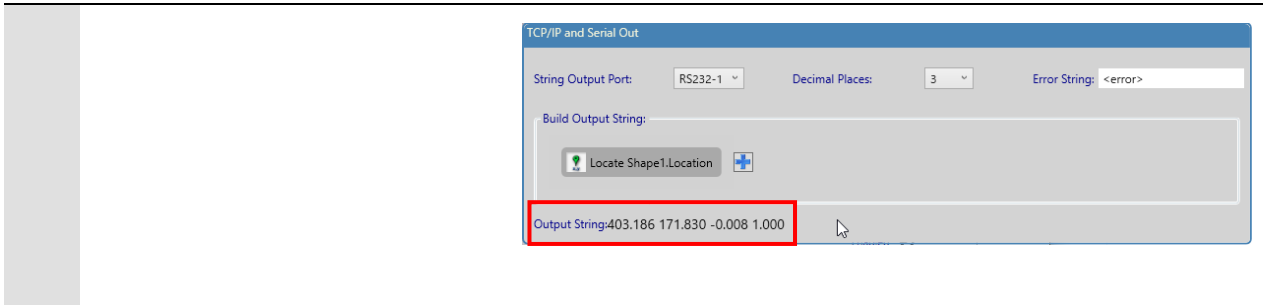

15 Repeat steps 13-14 to build the output string.

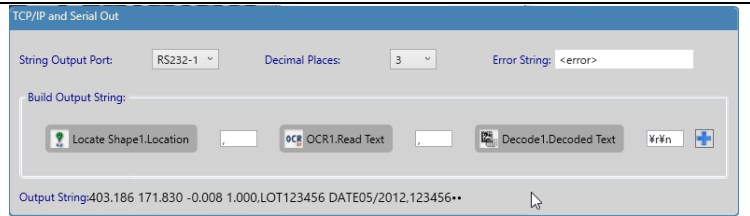

16 Go to Run view and download the job to smart camera.

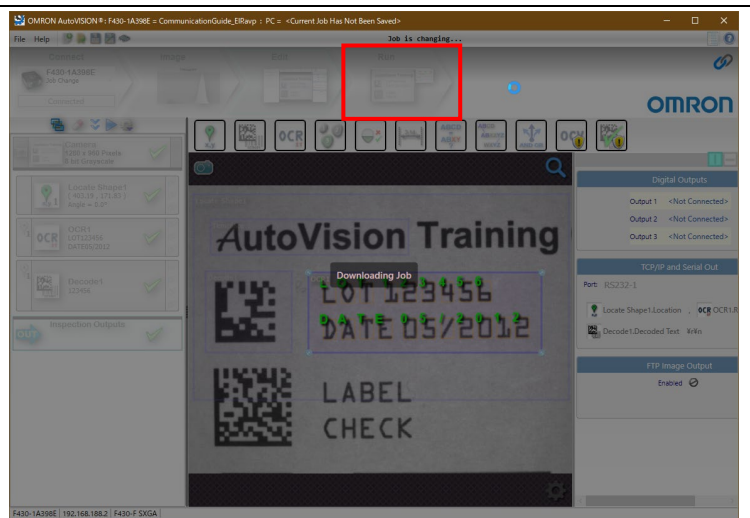

17 The download is complete when you can successfully transition to the Run screen.

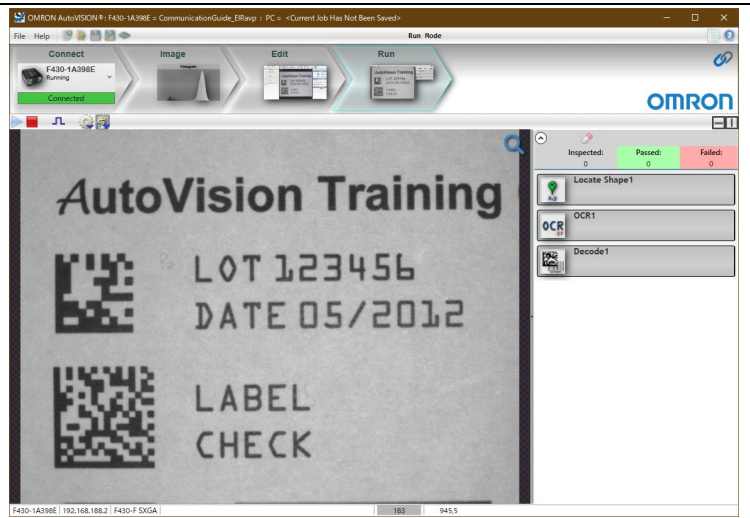

## 7.3. Controller Setup

Set up the Controller.

### 7.3.1. Hardware Settings

Set the switches on the Serial Communications Unit.



#### Precautions for Correct Use

These hardware settings must be done with the power OFF.

- 1 Confirm that the power to the controller is OFF.

\* If the power is ON, you may not be able to proceed in subsequent operations according to the described procedures.

Confirm the position of the physical switches on the front of the Serial Communications Unit according to the figure on the right.

Check the position of the "Port 2" (RS-232C) connector, referring to the figure on the right.

\* Assumes the use of "Port 2" on the Serial Communication Unit.

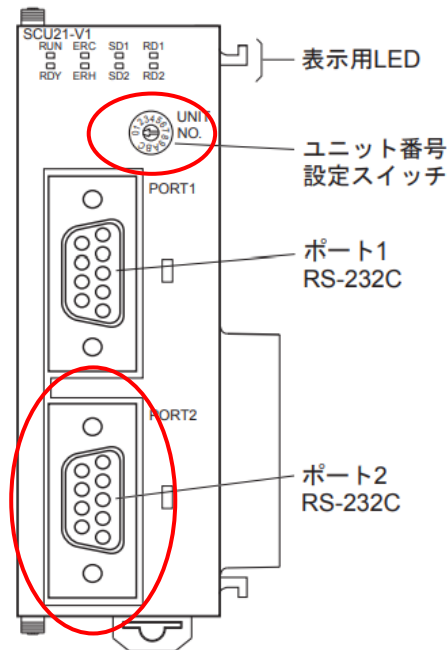

- 2 Set the Unit. No. switch to [0].  
(The factory default unit number is "0")



- 3 Connect the Serial Communication Unit to the controller as shown on the right. Connect the Smart Camera cable to the Serial Communication Unit. Connect the controller to the PC by USB cable.

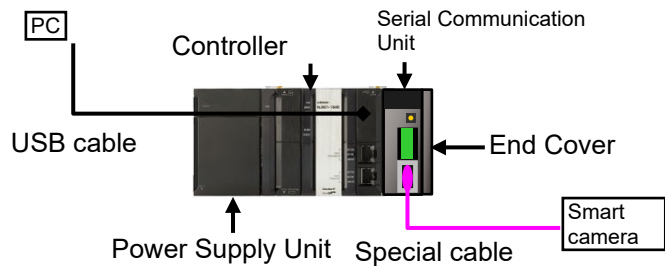

### 7.3.2. Start Sysmac Studio and Load the Project File

Launch Sysmac Studio and load the Project File in to Sysmac Studio.

Install Sysmac Studio and USB driver on the computer beforehand.

- 1 Make sure that the PC and controller are connected with the USB cable, and power on the controller.

Launch Sysmac Studio and click on [Import].

- \* If the User Account Control Dialog Box is displayed at startup, select the option to start.

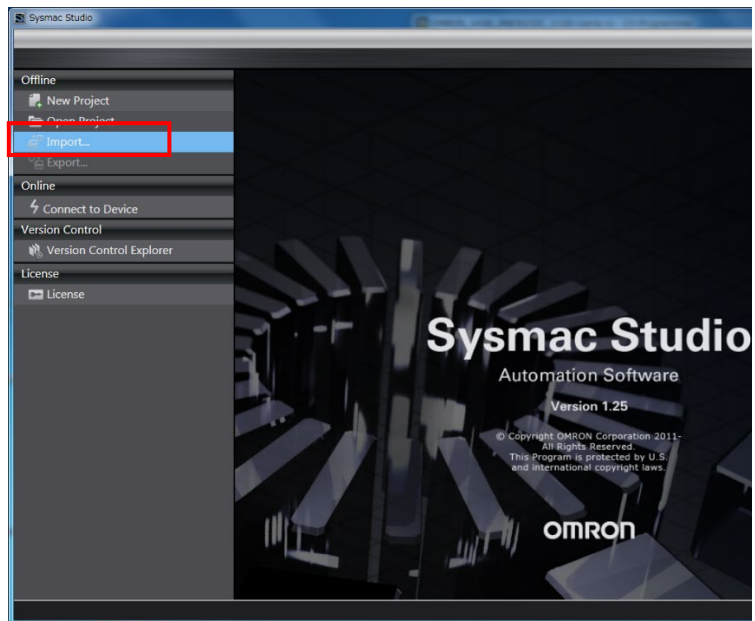

- 2 The [Import File] dialog opens. Select [OMRON\_F430\_NJ\_PMCR232\_C\_V100.smc2] and click [Open].

- \* Obtain the latest version of the project file from the OMRON Corporation website.

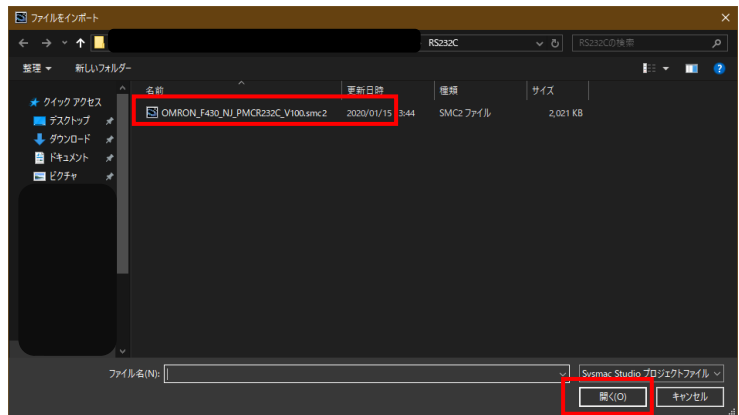

- 3 The [OMRON\_F430\_NJ\_PMCR232\_C\_V100] Project is displayed. The left side of the screen is called "Multiview Explorer", the right side is called "Toolbox", and the center is called "Edit window".

- \* If the error message "Cannot compare the repositories, the version on the target different from the source." Is displayed, change the Sysmac Studio version to at least the version indicated in "5.2. Device Configuration" or higher.

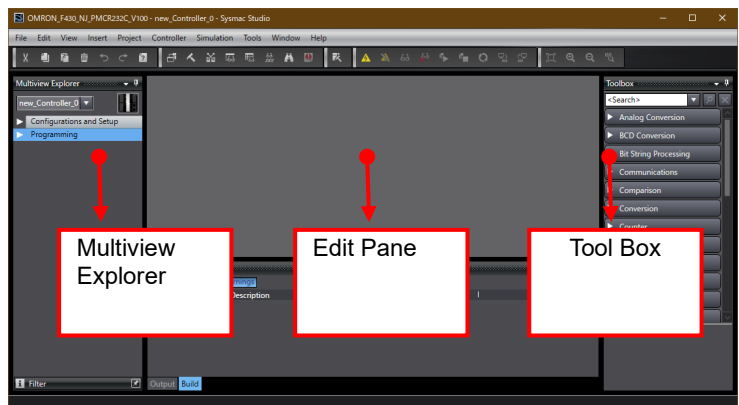



### 7.3.3. Verify Parameters and Execute Builds

Check the configuration parameters and execute program check and build of the project data.

- 1 Double-click [CPU EXPANSION RACKS] under "Configurations and Setup" in the Multiview Explorer.

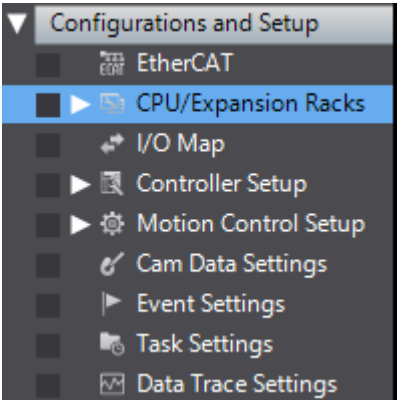
  
- 2 The [CPU EXPANSION RACKS] Tab Page is displayed in the Edit Pane. Connect the Serial Communication Unit as shown on the right. Confirm that the setting value of [CJ1W-SCU22] is displayed, [Device name] is [J01], and [Unit No.] is [0].

\* If the settings differ, change them to be the same as shown.

Click on [Edit Special Unit Settings].

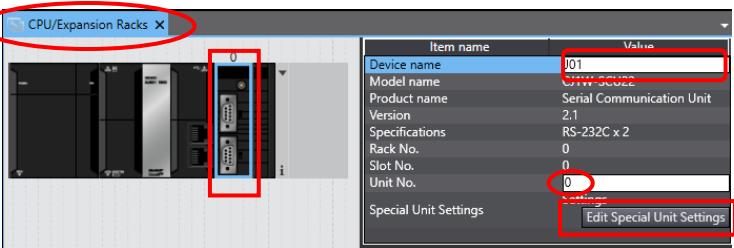

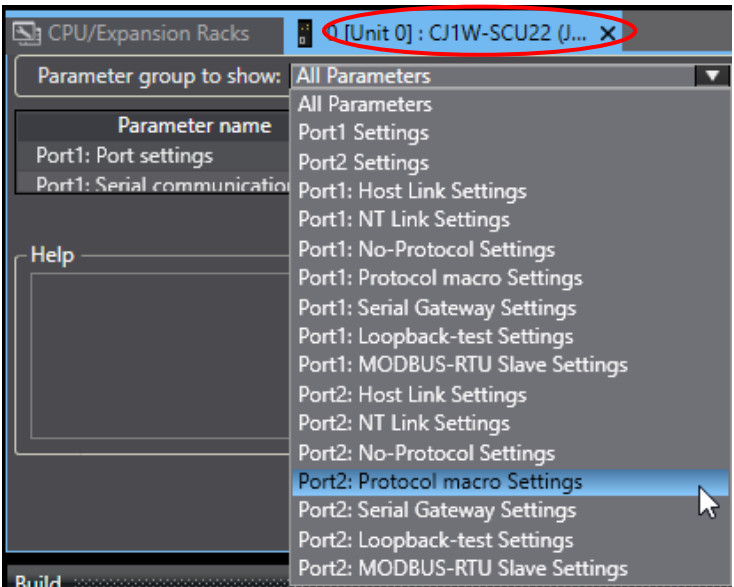
  
- 3 The [0[Unit 0] : ] Tab is displayed. Select "Port 2: Protocol macro settings" from the pull-down menu of "Display parameter group".



4 [Display Parameter Group] becomes [Port 2: Protocol Macro Setting].

The settings of [Port 2: Protocol macro setting] are displayed. Confirm that [Port 2: Arbitrary setting] is [Arbitrary setting] and that the other items are the same as the settings in section 6.1.

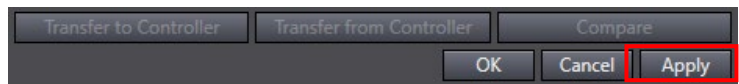
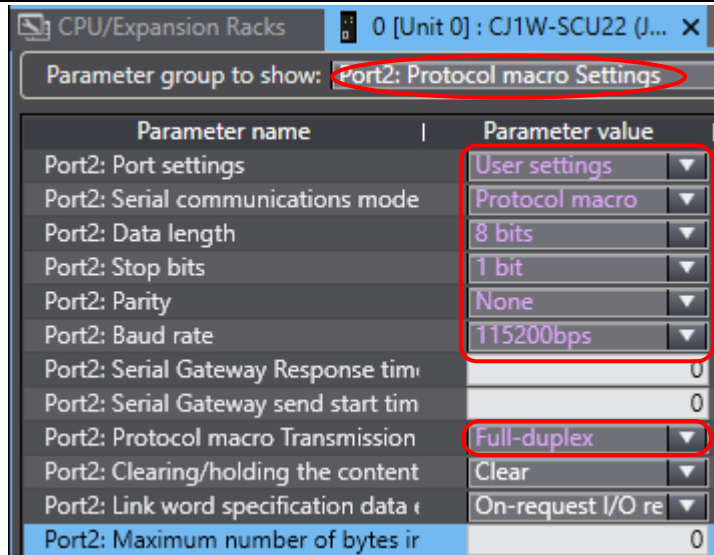
\* If the settings differ, change them to the values in the pull-down menu. If you change the value, click Apply.



5 Double-click [I/O Map] under "Configurations and Setup" in the Multiview Explorer. The [I/O Map] tab appears and the unit parameters are displayed.

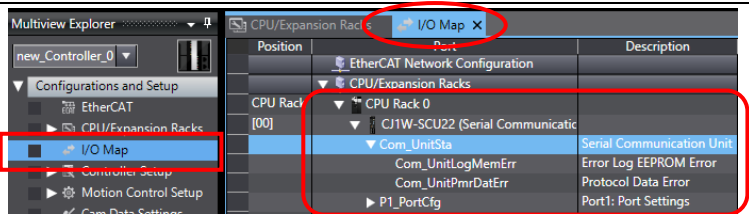

6 Make sure that the beginning of the data in the [Variable] area of the [I/O Map] screen is [J01], and that the [Variable type] area is set to [Global Variable].

\* If the settings are different, select [Create Device Variable] from the right mouse button menu with [CJ1W-SCU22] selected as shown in the right figure.

Port	Description	R/W	Data Type	Variable	Variable Comment	Variable Type
Serial Communication Unit	Serial Communication Unit	R	WORD	J01_Com_UnitSta		Global Variables
Error Log EEPROM Error	Error Log EEPROM Error	R	BOOL	J01_Com_UnitLog		Global Variables
Protocol Data Error	Protocol Data Error	R	BOOL	J01_Com_UnitPmr		Global Variables
Port1: Port Settings	Port1: Port Settings	RW	WORD	J01_P1_PortCfg		Global Variables
Port1: User-specified Settings	Port1: User-specified Settings	RW	BOOL	J01_P1_SerSetCfg		Global Variables

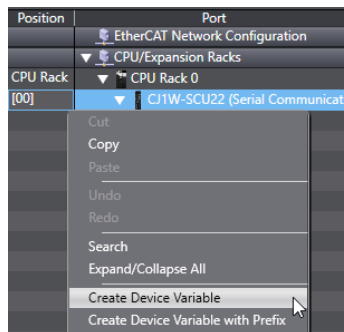

7 Double-click "Task Settings" under "Configurations and Setup" in the Multiview Explorer.

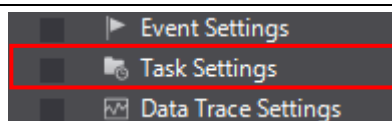

8 The [Task Settings] tab will be displayed in [Edit Pane]. Select [Program Assignment Settings] and confirm that [Program0] is set in [PrimaryTask].

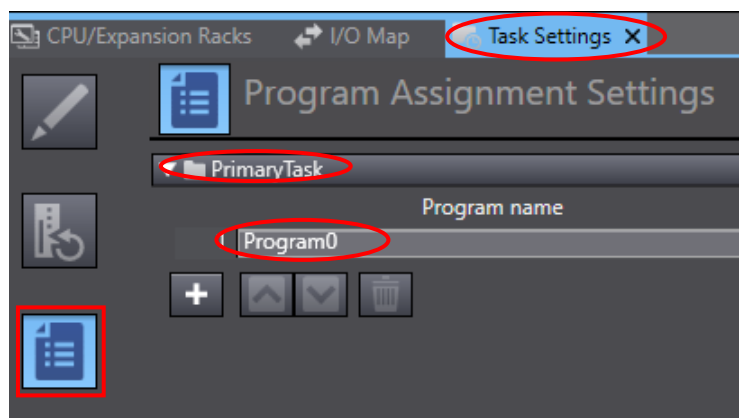

9 From the Main Menu in Sysmac Studio, select [Project] – [Check All Programs].

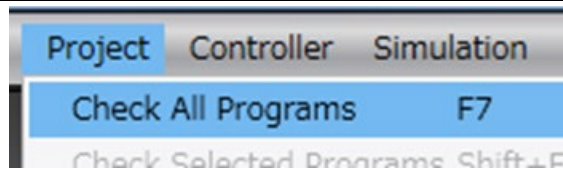

10 [Build Tab Page] is displayed under [Edit Pane]. Confirm that both the Error and Warning are "0".

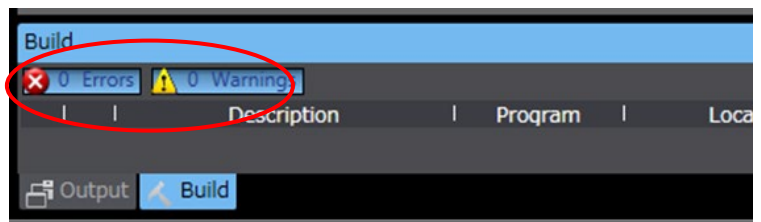

11 From the Menu Bar, select [Project] – [Rebuild Controller].

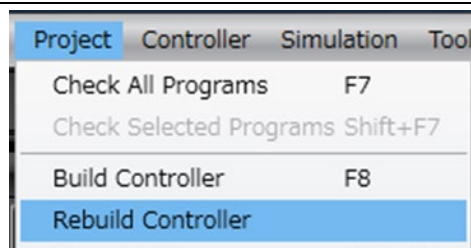

The build progress screen is displayed.

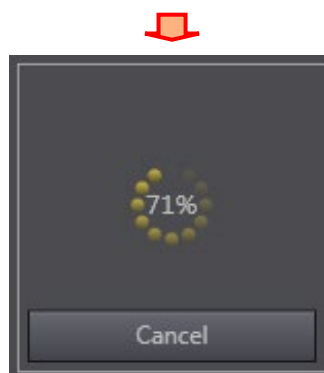

12 On the Build tab page, confirm that [0] is shown for both Errors and Warnings.

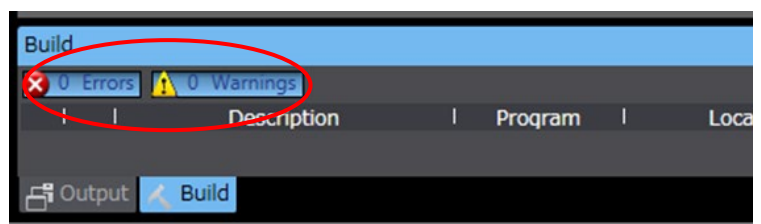

### 7.3.4. Connect Online and Transfer Project Data

Connect online in Sysmac Studio and transfer the project data to Controller.

 **WARNING**

Before transferring the user program, "Configuration / Setup" data, device variables, and CJ unit memory values from Sysmac Studio, check the safety of the transfer destination node.

The device or machine may operate unexpectedly regardless of the operation mode of the CPU module.



 **CAUTION**

Be sure to confirm safety before resetting the controller or unit.

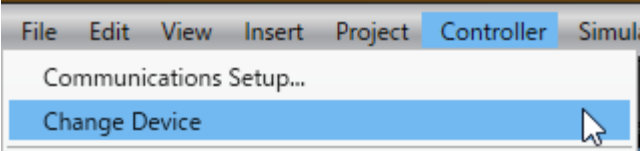

- 1 From the Menu Bar, select [Controller] – [Change Device].

- 2 The Change Device Dialog Box is displayed. Confirm that [Device] and [Version] are set to use the controller in the right figure, and click [OK].

\* If the settings are different, select from the pull-down menu.

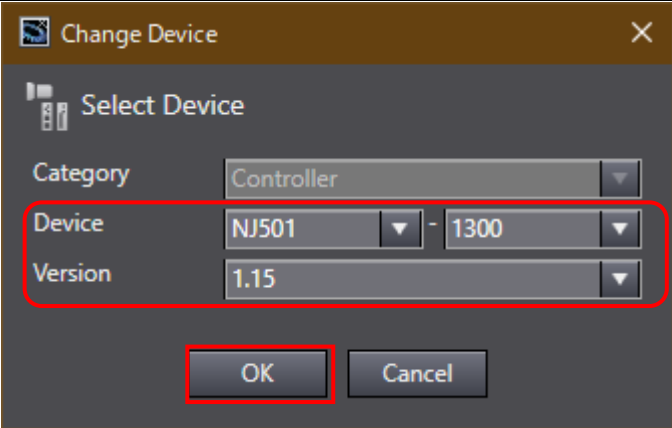
- 3 If the setting shown in Item 2 is changed, the [Build] dialog is displayed. Click [Yes].

\* If it has not been changed, this dialog will not appear.

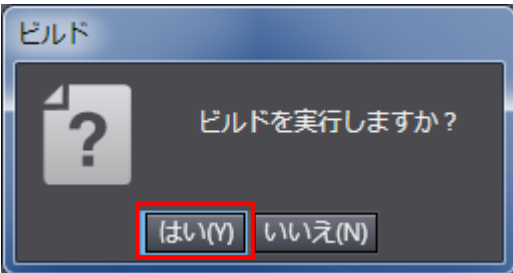

4 From the Menu Bar, select [Controller] – [Communications Setup].

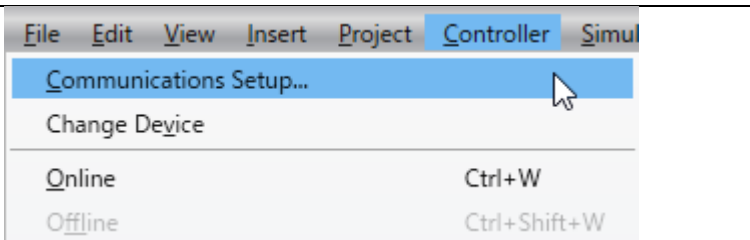

5 The [Communications Setup] dialog opens. For [Connection type], select [Direct connection via USB]. Click [OK].

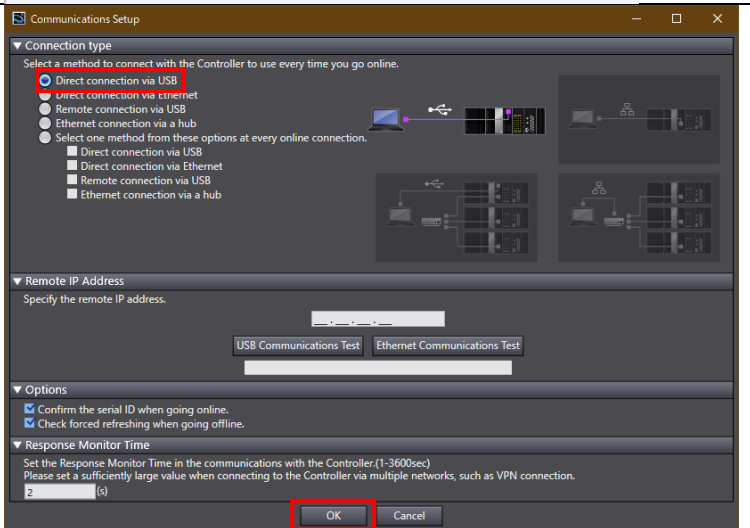

6 From the Menu Bar, select [Controller] – [Online].

\* If the confirmation dialog box shown on the right is displayed, the controller format or version is different from the device setting in the project file. Confirm the controller model and version, and the device settings in the project file, return to Step 1, and execute the procedure in this section again. Click [OK] in the dialog to close it.

\* The model and version displayed in the confirmation dialog differ depending on the controller used and the device settings of the project file.

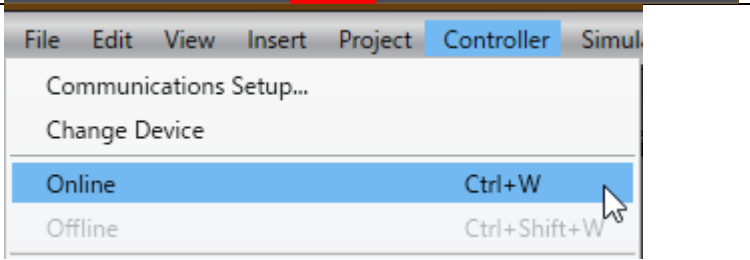

\* Confirmation Dialog example 1

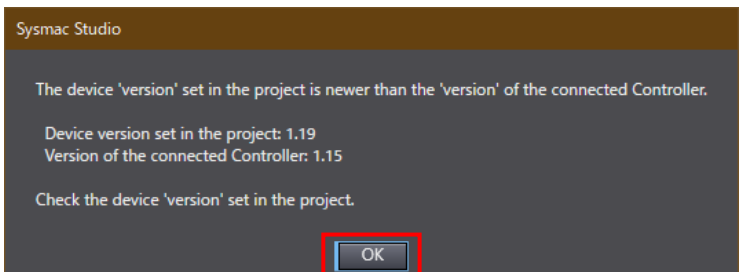
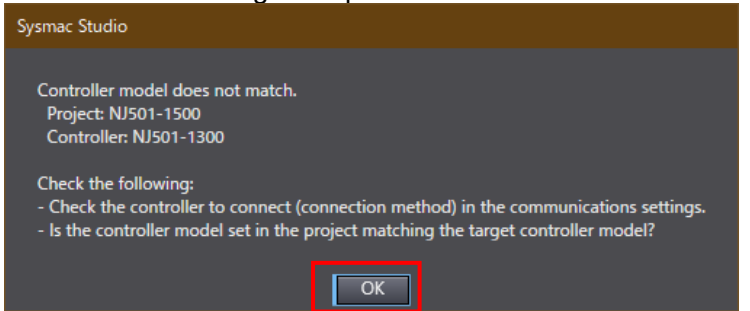

7 The Confirmation dialog shown on the right will be displayed. Click [Yes].

- \* The dialog that is displayed differs depending on the status of the controller you are using, but make the selection to proceed with processing.
- \* The Serial ID displayed differs by device used.

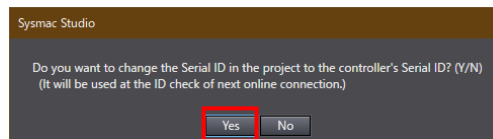
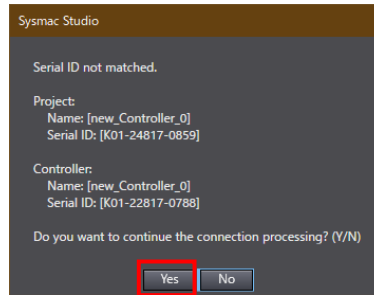
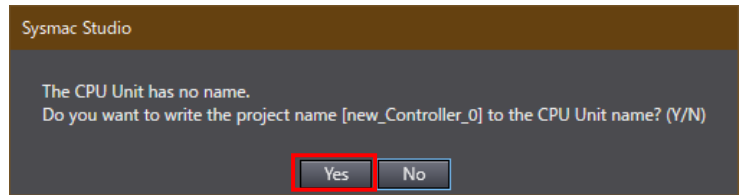

**Note**

Refer to Chapter 5 "Controller Configurations and Setup" in the "Sysmac Studio Version 1.0 Operation Manual" (W504) for details on online connection to the controller.

8 When you are online, a yellow frame will be displayed in the upper part of the [Edit window].

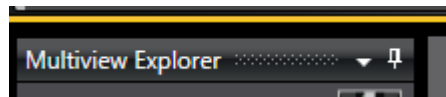

9 From the Menu Bar, select [Controller] – [Synchronization].

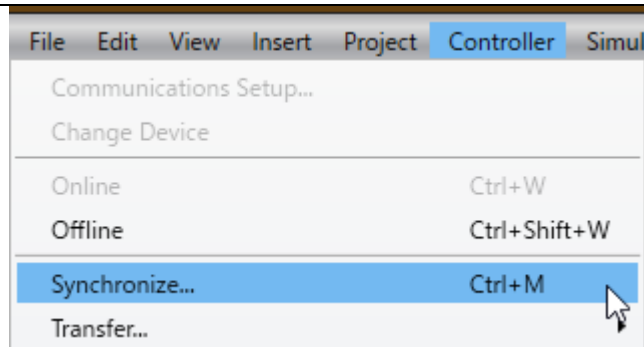

10 The [Synchronization] dialog opens. Make sure that the data you want to transfer (in the right figure, [NJ501]) is checked, and click [Transfer to Controller].

- \* Executing [Transfer to Controller] transfers the Sysmac Studio Project data to the controller and checks that the data was received.

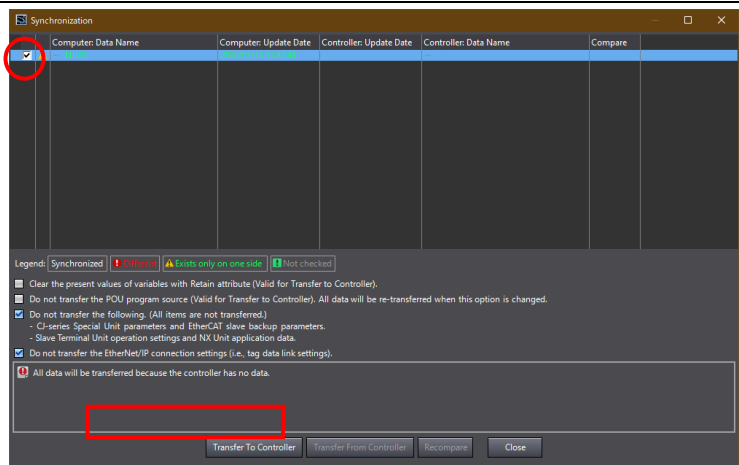

11 The Confirm dialog is displayed. Click [Yes].

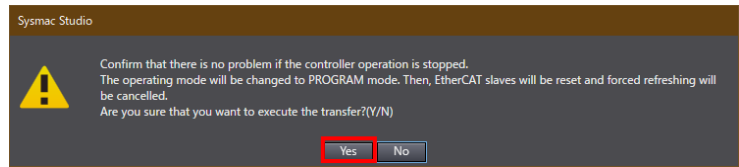

The "Synchronizing" dialog appears.



The Confirm dialog is displayed. Click [No].

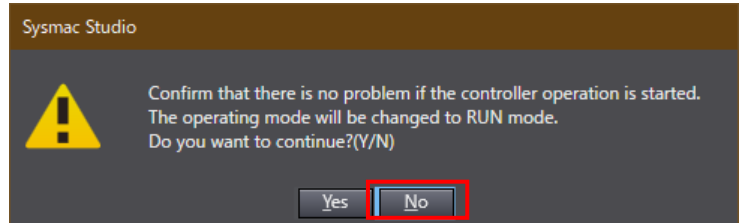

\* After this, the Operating Mode will be in "Program mode", so select [No] here.

12 Confirm that the text color of the synchronized data becomes the color indicated for "Synchronized" and the "Synchronization Successful" message is displayed. If there is no problem, click [Close].

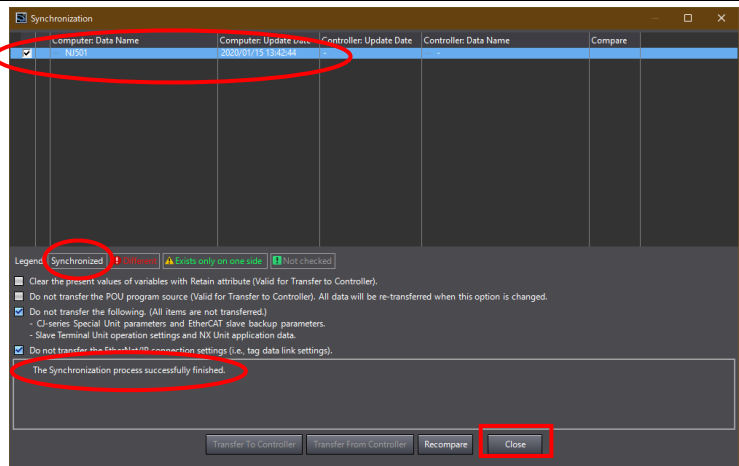

\* If synchronization fails, check the wiring and re-execute the procedure in this section.

13 From the Menu Bar, select [Controller] – [Reset].

\* If [Reset] cannot be selected, [Operating Mode] is [RUN Mode]. From the menu bar, select [Controlller]-[Operating Mode]-[PROGRAM Mode]. After you have changed it to [PRORAM Mode], you can then perform the procedure in this section.



14 The Confirmation dialog may be displayed multiple times. Click [Yes].

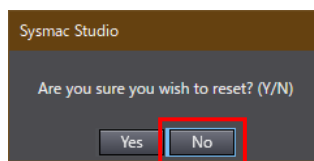
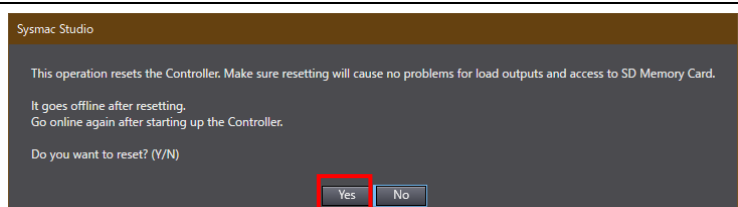

15 The controller is reset, SysmacStudio goes offline, and the yellow frame at the top disappears. After performing Steps 6 to 8 again, it will become Online.

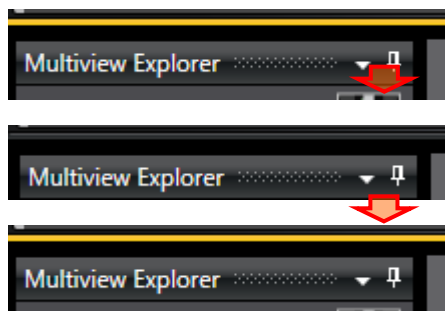



### 7.3.5. Transfer Unit Settings

Set the parameters to send to the Serial Communications Unit.

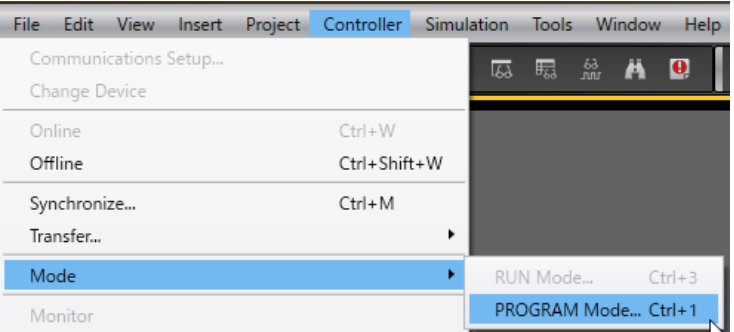
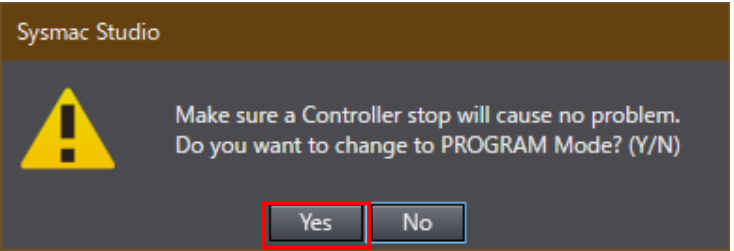
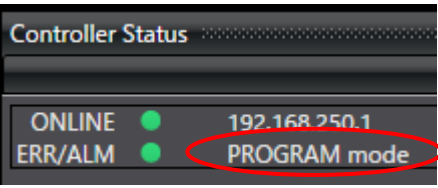
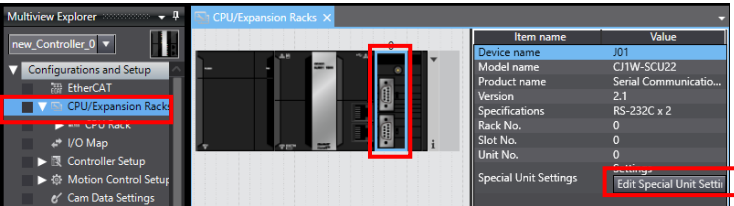
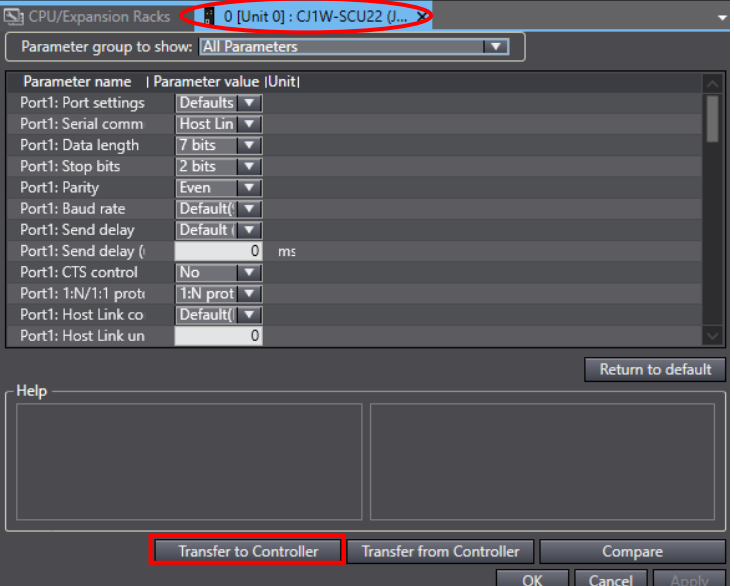
<p>1 From the Menu select [Controller] - [Operating Mode] - [PROGRAM Mode].</p>	
<p>2 The Confirm dialog is displayed. Click [Yes].</p>	
<p>3 In the [Controller Status] pane, [PROGRAM Mode] is displayed.</p>	
<p>4 Double-click [CPU EXPANSION RACKS] under "Configurations and Setup" in the Multiview Explorer. Select the Serial Communication Unit at the top of the screen. Click [Unit Editor].</p>	
<p>5 The [0[Unit 0] : ] Tab is displayed. Click the [Transfer to Controller] Button.</p>	

6 The Confirmation dialog is displayed.  
Click [Yes].

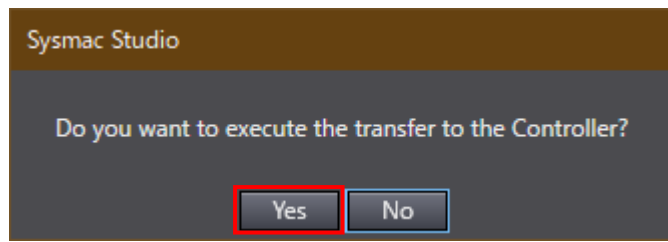

After the Transferring dialog is displayed, a Confirmation dialog is displayed.  
Click [Yes].

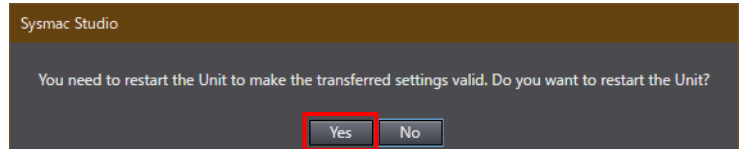

7 The [Port Selection] dialog opens.  
Select [All Ports] and click [OK].

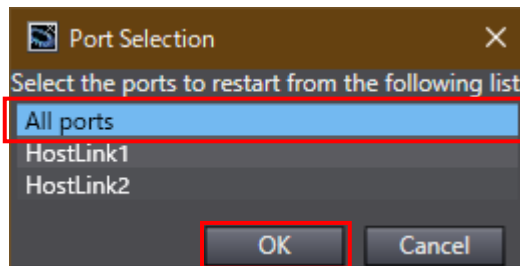

8 The Confirmation dialog is displayed.  
Click [OK].

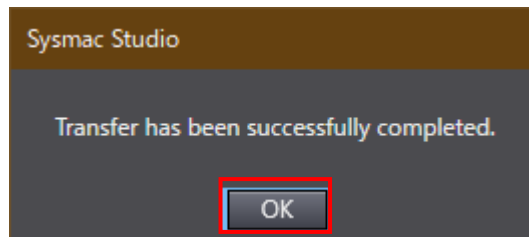

9 Open the pull-down menu of [Display Parameter Group] and select [Port 2: Protocol Macro Setting].  
Click [Compare].

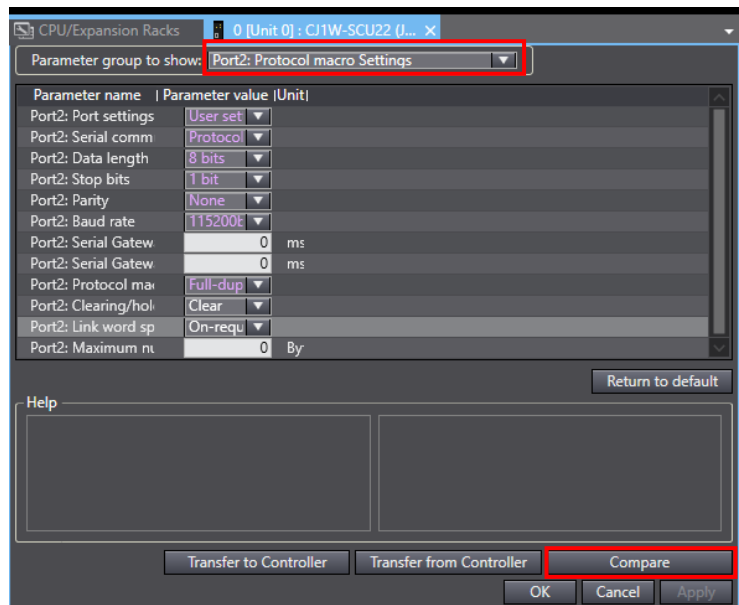

- 10 Check that "≠" (mismatch) does not occur as shown in the red frame in the right figure.

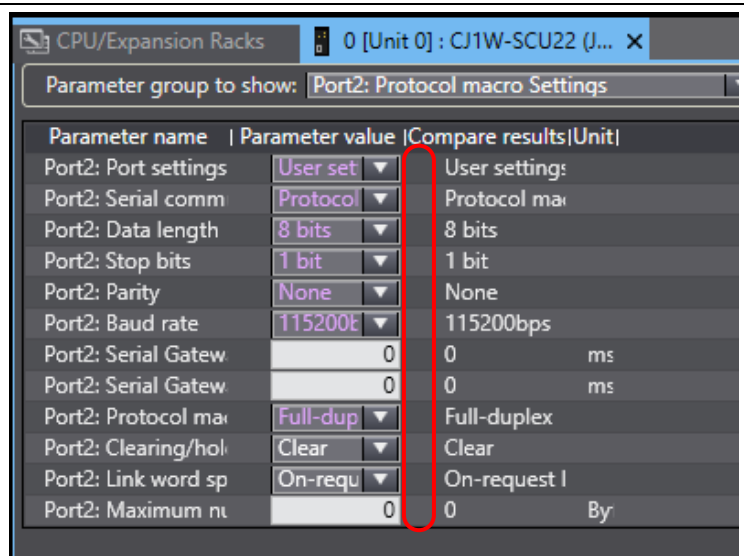

CPU/Expansion Racks 0 [Unit 0] : CJ1W-SCU22 (J... x

Parameter group to show: Port2: Protocol macro Settings

Parameter name	Parameter value	Compare results	Unit
Port2: Port settings	User set		User settings:
Port2: Serial comm	Protocol		Protocol ma
Port2: Data length	8 bits		8 bits
Port2: Stop bits	1 bit		1 bit
Port2: Parity	None		None
Port2: Baud rate	115200		115200bps
Port2: Serial Gatew.	0		ms
Port2: Serial Gatew.	0		ms
Port2: Protocol ma	Full-dup		Full-duplex
Port2: Clearing/hol	Clear		Clear
Port2: Link word sp	On-requ		On-request I
Port2: Maximum nt	0		By

### 7.3.6. Starting CX-Protocol and Loading Protocol Macro Data

Start CX-Protocol and load the Protocol Macro Data.

1 Start CX-Protocol.

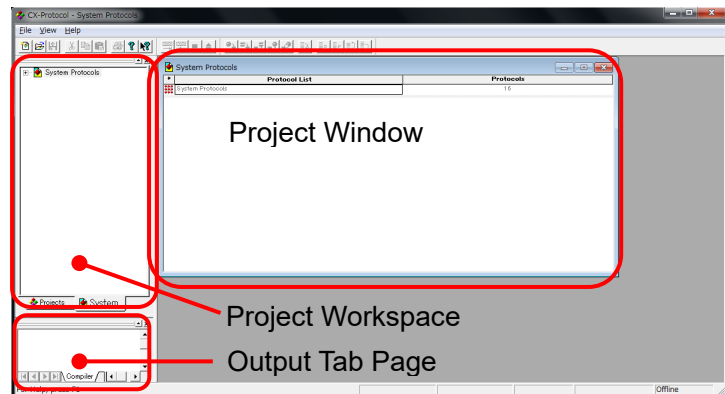

(CX-Protocol)

2 From the Menu Bar, select [File] – [Open].

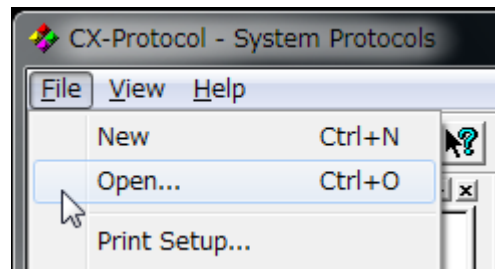

3 The [Open] dialog appears. Select [OMRON\_F430\_PMCR\_V100.p sw] and click [Open].

\* Obtain the latest version of the Protocol Macro Data file from the OMRON Corporation website.

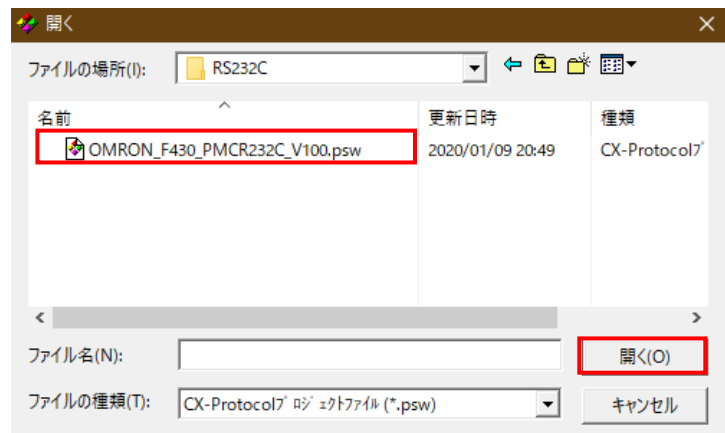

4 The protocol macro data loaded is displayed in the project workspace and project window respectively.

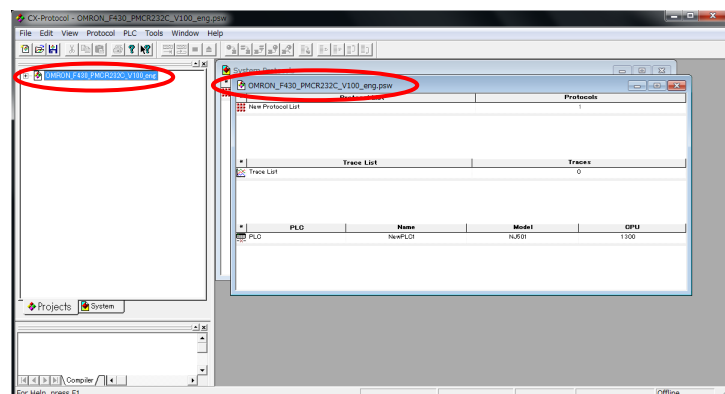

### 7.3.7. Set Online Connection and Transfer the Protocol Macro Data

Set the Online connection for CX-Protocol and Transfer the Protocol Macro Data for serial communication

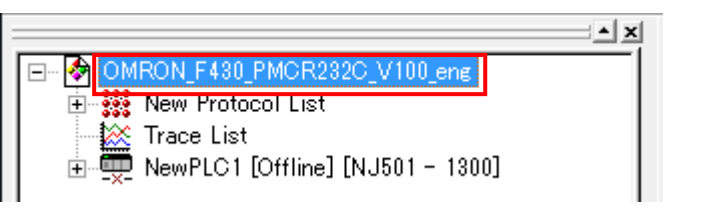
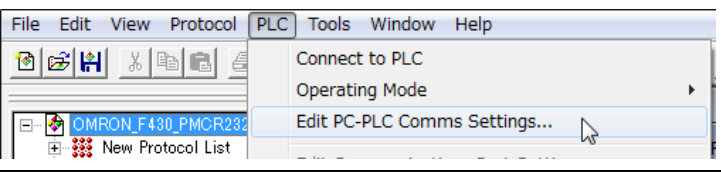
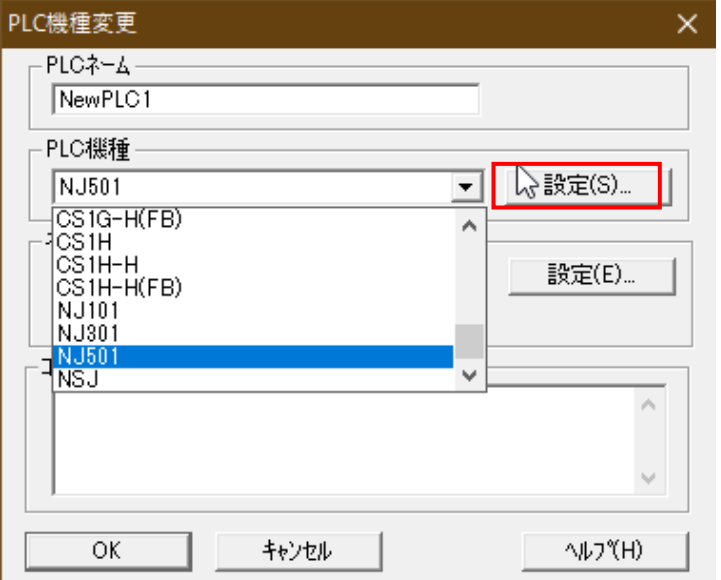
<p>1 Double-click [OMRON_F430_PMCR_V100] in the project workspace to open the tree.</p>	
<p>2 From the menu bar, select [PLC] – [Connect].</p>	
<p>3 The [Change PLC] dialog appears. From the [Device type] pulldown list, select the PLC type and click [Settings].</p> <p>* In this document, [NJ501] is used.</p>	

- 4 The [Change PLC] dialog is displayed. From the [CPU type] pulldown list, select the CPU type and click [OK].

\* In this document, [1300] is used.

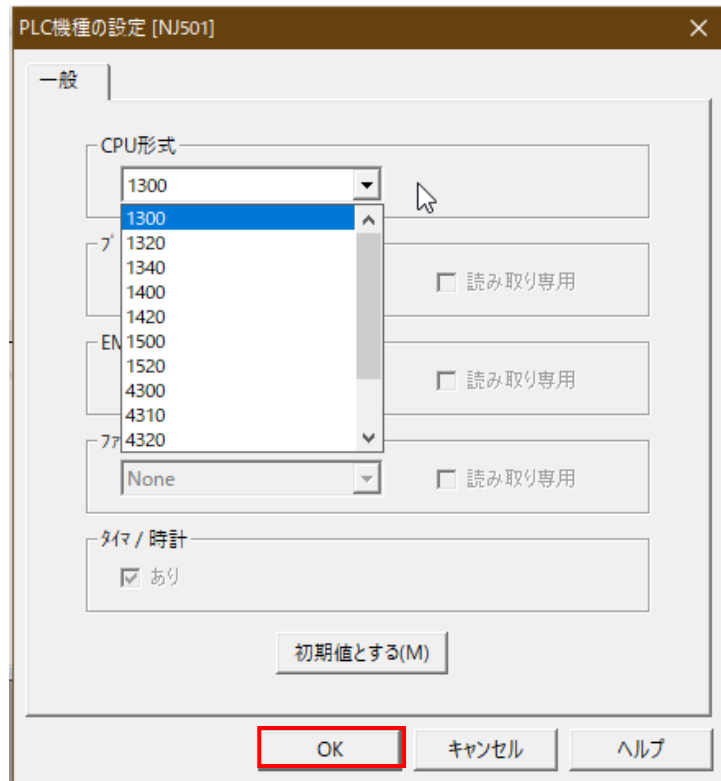

- 5 In the [Change PLC] dialog, confirm that [USB] is set as the [Network type] and click [OK].

\* If [USB] is not already set as the [Network type], select it from the pulldown menu.

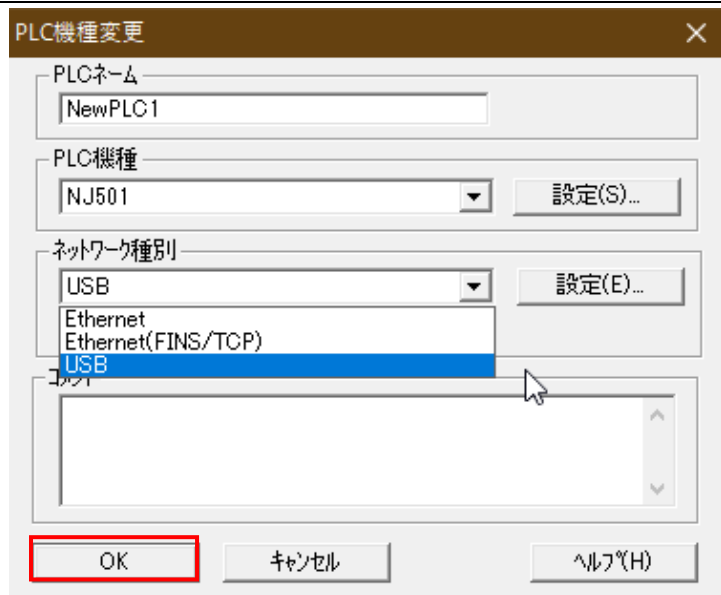

- 6 From the menu bar, select [PLC] - [Connect].

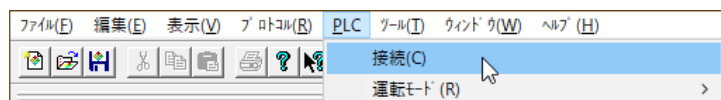

- 7 Change the display of PLC icon in the project workspace from [Offline] to [Program], and confirm that online connection with the controller is possible.

\* If [RUN] is displayed, perform steps 8 to 9 below to change to [Program].

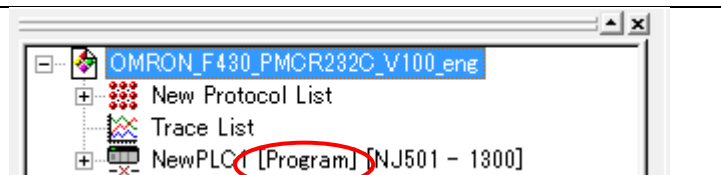

8 If the Operating Mode of the controller is [Run], select [PLC] - [Operating Mode] - [Program] from the menu bar.

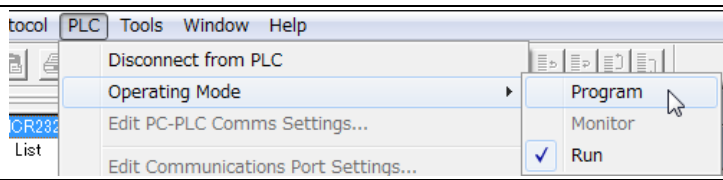

9 The dialog shown on the right will be displayed. Click [Yes]. Make sure that the mode is changed to Program mode, as shown in step 7.

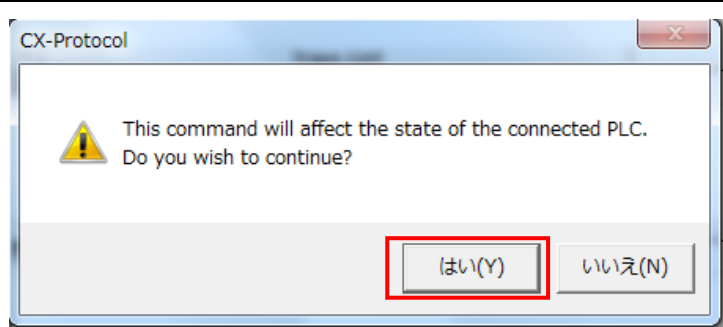

10 Double-click "New Protocol List" in the project workspace to open the tree.

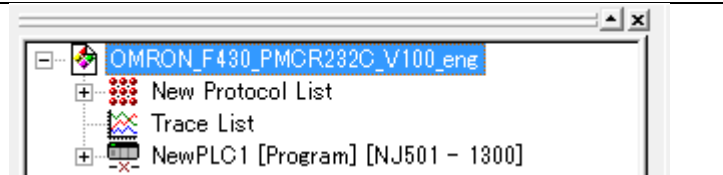

11 The project window shown on the right will be displayed. Make sure that [SCU[0]] is entered in [Target].

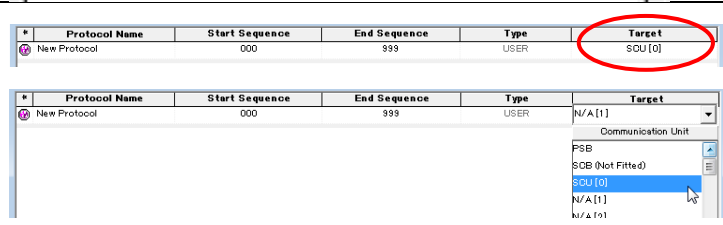

\* If [SCU[0]] is not already entered, select [SCU[0]] as shown on the right.

12 With "New Protocol List" selected, from the menu select [Protocol] - [Download Protocols].

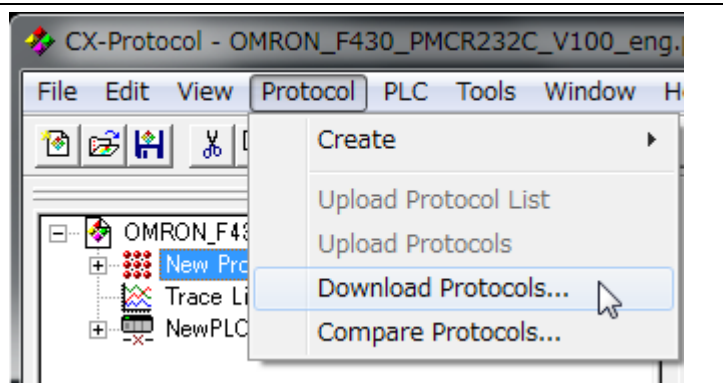

13 The dialog on the right is displayed. Check Include Source Information, and click Compile.

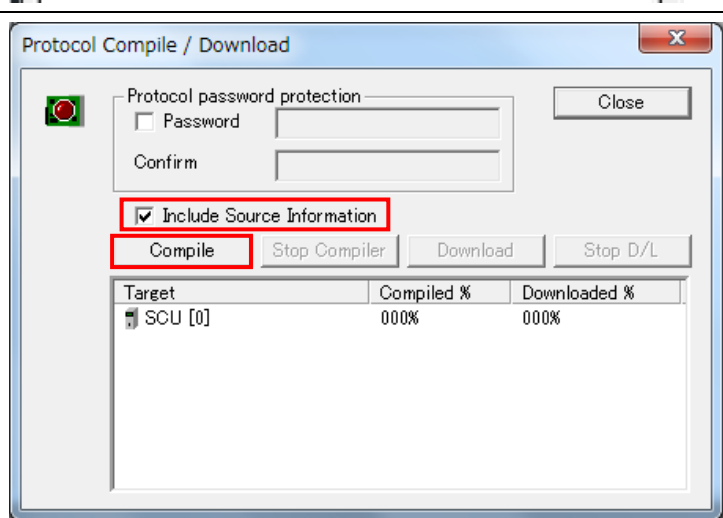

- 14 Compiling is complete when [Compiled%] becomes [100%] in the dialog on the right. After confirming Compile is finished, click on [Download].

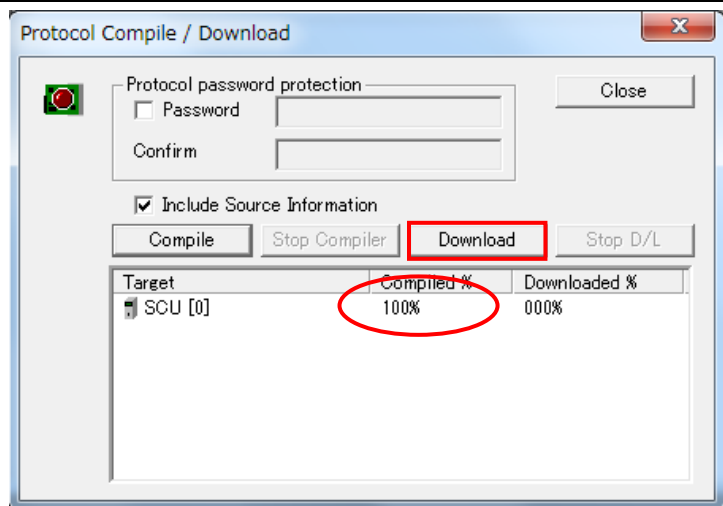

- 15 The dialog shown on the right will be displayed. Click [OK].

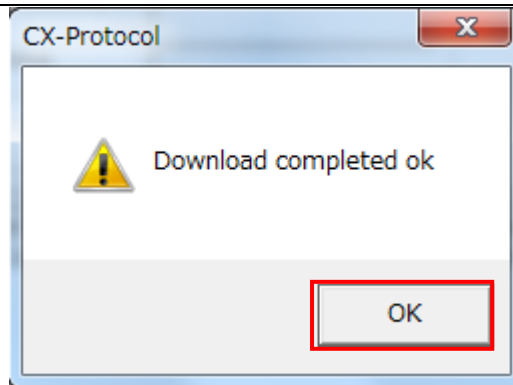

- 16 Confirm that the transfer is complete [100%] as shown on the right, and then click Close.

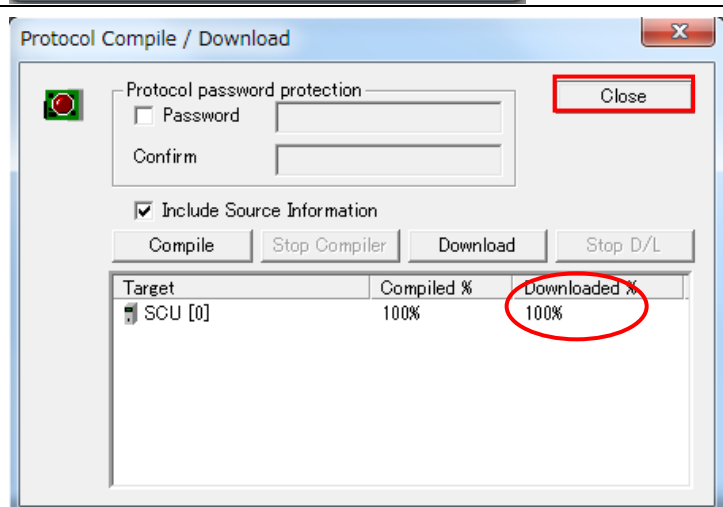

- 17 With "New Protocol List" selected, from the menu select [Protocol] - [Compare Protocols].

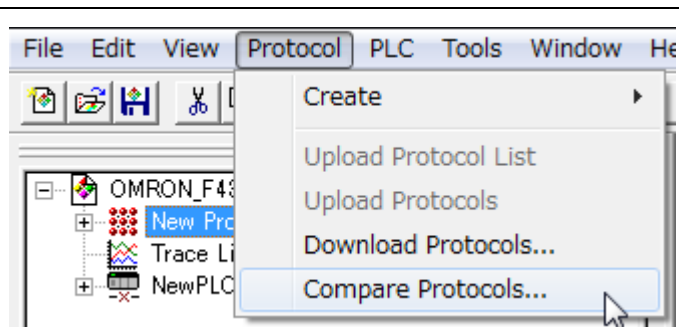



- 18 The dialog on the right is displayed. Check Include Source Information, and click Compile.

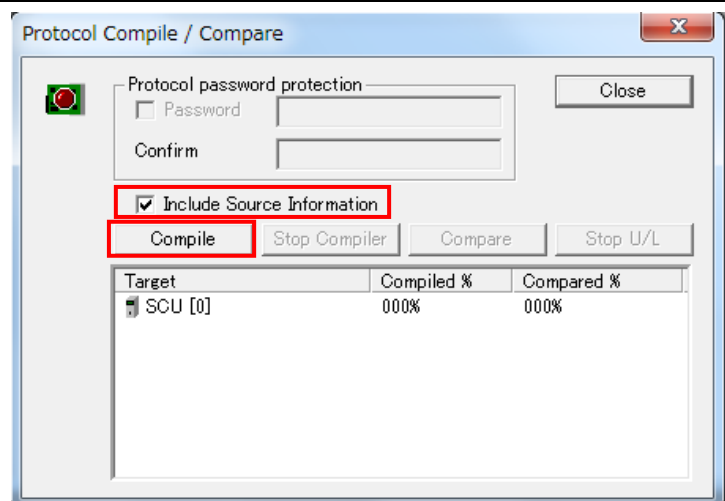

- 19 Compiling is complete when [Compiled%] becomes [100%] in the dialog on the right. After confirming Compile is finished, click on [Download].

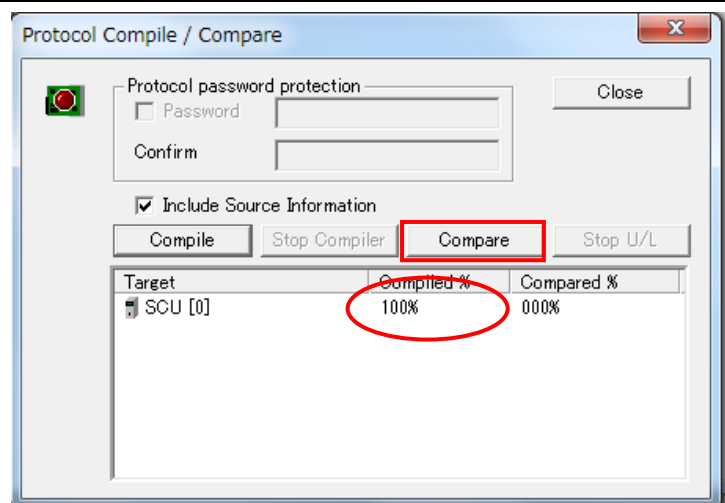

- 20 The dialog shown on the right will be displayed. Click [OK].

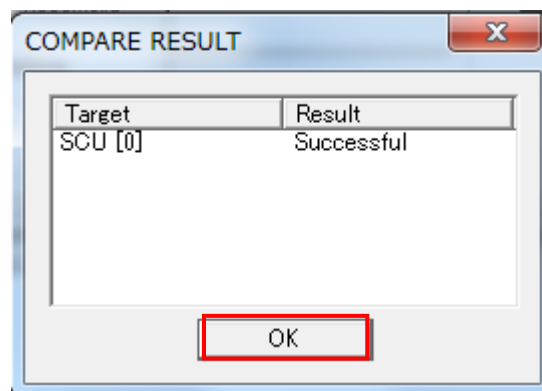

21 Confirm that the [Comparison%] is complete [100%] as shown on the right, and then click Close.

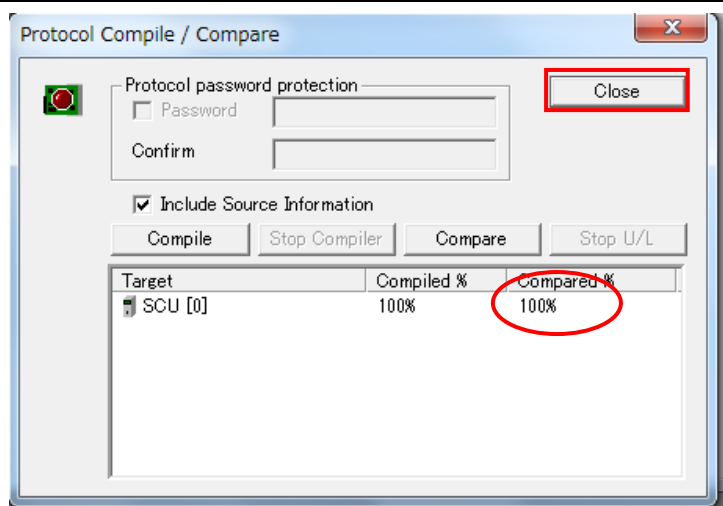

## 7.4. Confirm Serial Communications

Run the program and verify that serial communication is working properly.



Sufficiently confirm safety before you change the values of variables on a Watch Tab Page when the Sysmac Studio is online with the CPU Unit. Incorrect operation may cause the devices connected to the output unit to operate regardless of the operation mode of the controller.



### Precautions for Correct Use

The explanations of procedures given in this document are based on the use of the factory default settings for the smart camera. If the smart camera is not in the factory default settings, be sure to initialize it referring to the procedures described in section "8.2. Initializing the smart camera".

### Precautions for Correct Use

Before performing the following steps, confirm that the serial cable is securely connected. If it is not connected, first turn the power to each device OFF and then connect the serial cable.

#### 7.4.1. Start Trace

Start Trace with CX-Protocol.

- 1 From the CX-Protocol menu bar, select [PLC] - [Operating Mode] - [Run].

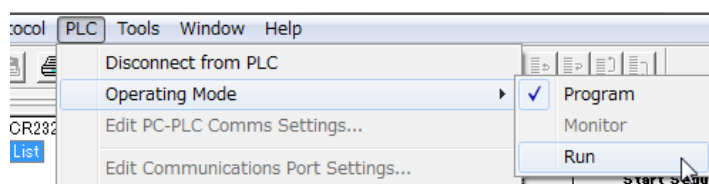

- 2 The dialog shown on the right will be displayed. Click [Yes].

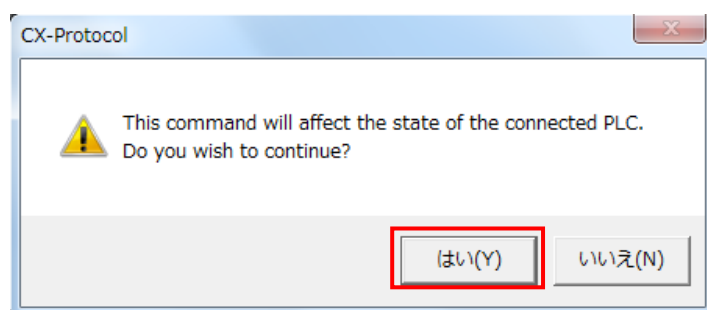

- 3 After confirming that the Operating Mode has changed to [Run], double click [NewPLC1 [Run] [NJ501 - 1300]].

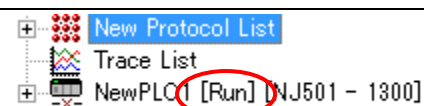

4 The tree under [NewPLC1] will open. Select the Serial Communication Unit. ([SCU[0]] in the figure on the right).

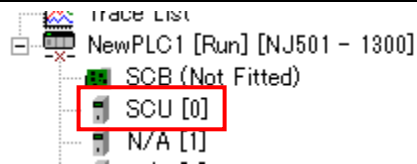

5 In the Project window, select the [Trace2] icon ( ). (Verify that [Trace 2] is highlighted as shown on the right)



\* [Trace 2] corresponds to "Port 2" of the serial communication unit.

6 From the Menu bar, select [PLC] - [Start Trace] - [One-shot Trace].

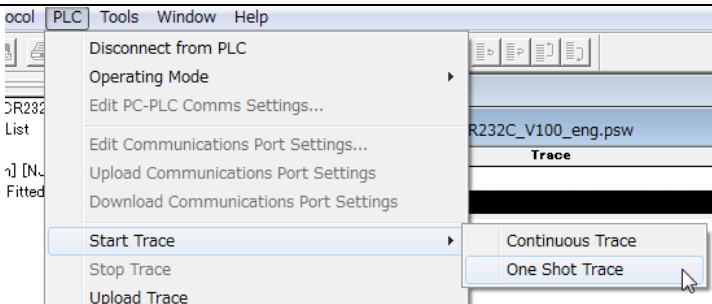



7 Confirm that the status of [Trace 2] in the Project Window is [One-shot Trace Running].

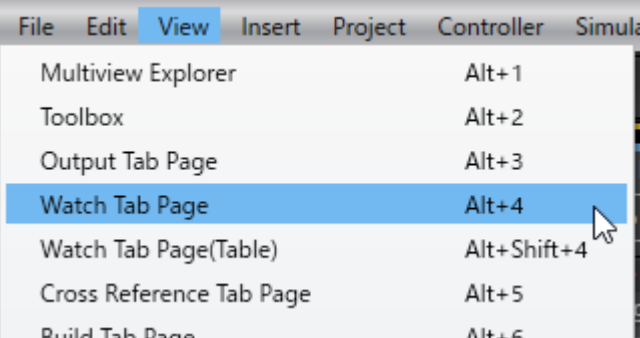
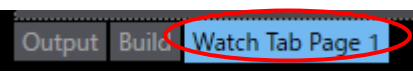
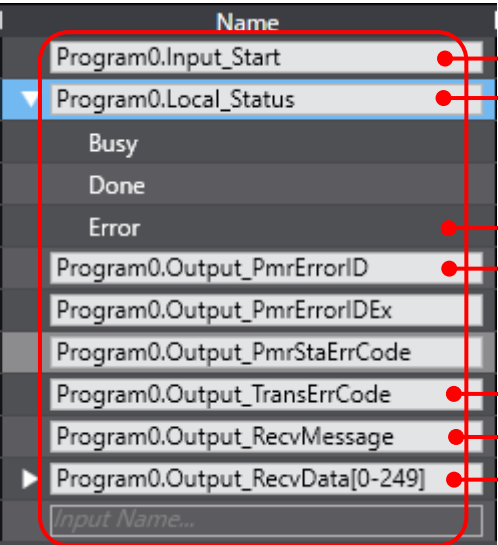

## 7.4.2. Running the program

Run the program in Sysmac Studio.

<p>1 From Menu Bar in Sysmac Studio, select [View] - [Watch Tab Page].</p>	
<p>2 The [Watch Tab Page] is displayed under the [Edit Window].</p>	
<p>3 Confirm that the variables shown on the right are displayed in the [Name] area.</p> <ul style="list-style-type: none"> <li>* If a required variable needs to be added, click [Input Name ...] to add it.</li> <li>* If <input type="checkbox"/> on the left side of the variable is displayed as <input type="checkbox"/> click <input type="checkbox"/> to expand the structure variable structure.</li> <li>* In the following explanation, "Program0" in [Name] is omitted.</li> </ul>	 <ul style="list-style-type: none"> <li>Start input</li> <li>Program Execution Status</li> <li>Types</li> <li>Error code</li> <li>After Text string conversion</li> <li>Receive data</li> <li>Receive data Storage Area</li> </ul>
<p>4 Use the test object on the right as the workpiece example. Set the smart camera to the position where the object shown on the right can be inspected.</p>	 <p><b>AutoVision Training Card 1</b></p> <p>LOT 123456 DATE 05/2012</p> <p>LABEL CHECK</p> <p>VISION SIMPLIFIED</p> <p>OMRON AUTOVISION</p>

5 Click [TRUE] in the [Modify] area of [Input\_Start].

Name	Online value	Modify
Program0.Input_Start	False	<input type="button" value="TRUE"/> <input type="button" value="FALSE"/>



The [Online value] for [Input\_Start] becomes [True].

Name	Online value	Modify
Program0.Input_Start	True	<input type="button" value="TRUE"/> <input type="button" value="FALSE"/>

When the program is run, serial communication with the Smart Camera is established and inspection is executed.

\* If it is a successful inspection, the [PASS LED] on the Smart Camera is lit green.

### 7.4.3. Confirm Trace Data

Confirm that the correct data is transmitted and received with the Trace Data of CX-Protocol.

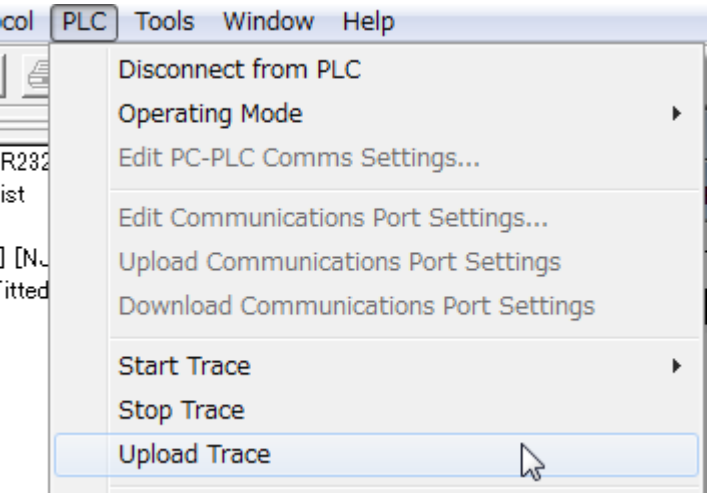
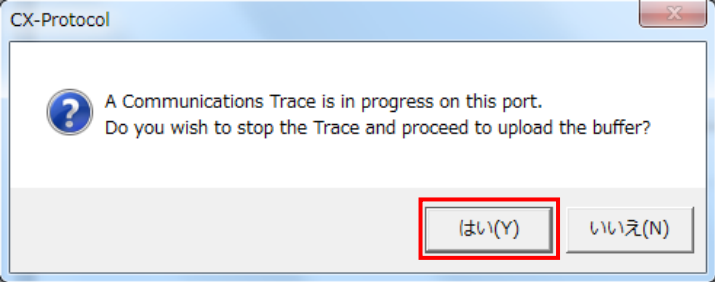
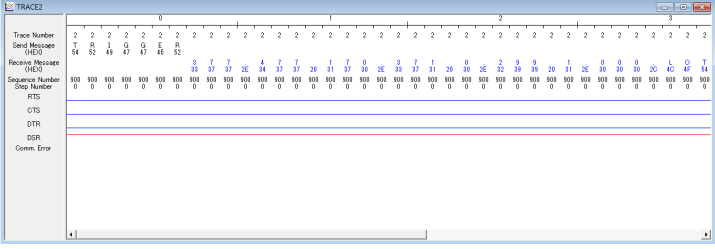
<p>1 From the CX-Protocol menu bar, select [PLC] - [Upload Trace].</p>	
<p>2 The dialog shown on the right will be displayed. Click [Yes].</p>	
<p>3 Check the Sent and Received messages in the trace data file as shown on the right.</p> <p>* In the example on the right, you can see that the controller has sent the "Serial Trigger" command and received the measurement result contents of Step 4 in section 7.4.2.</p>	 <p>■ Send Data Hexidecimal: 54 52 49 47 47 45 52 String: TRIGGER</p> <p>■ Receive Data Hexidecimal: 33 37 37 2E 34 37 37 20 31 37 30 2E 33 37 31 ... (Omitted) String: "377.477 170.371 ... (Omitted)</p>

### 7.4.4. Confirm Received Data

In Sysmac Studio, check that the correct data is written to the controller variable.

<p><b>1</b> Also confirm that [Online value] of [Local_Status.Done] indicating the program execution status is [True].</p> <p>* You can see that the program ended normally.</p> <p>* If it ends with an error, [Local_Status.Error] becomes [True]. Refer to Step 2 again when correcting it.</p>	<p><b>[When it ends normally]</b></p> <table border="1"> <thead> <tr> <th>Name</th> <th>Online value</th> </tr> </thead> <tbody> <tr> <td>Program0.Input_Start</td> <td>True</td> </tr> <tr> <td>Program0.Local_Status</td> <td></td> </tr> <tr> <td>  Busy</td> <td>False</td> </tr> <tr> <td>  Done</td> <td>True</td> </tr> <tr> <td>  Error</td> <td>False</td> </tr> </tbody> </table> <p><b>[When it ends with an error]</b></p> <table border="1"> <thead> <tr> <th>Name</th> <th>Online value</th> </tr> </thead> <tbody> <tr> <td>Program0.Input_Start</td> <td>True</td> </tr> <tr> <td>Program0.Local_Status</td> <td></td> </tr> <tr> <td>  Busy</td> <td>False</td> </tr> <tr> <td>  Done</td> <td>False</td> </tr> <tr> <td>  Error</td> <td>True</td> </tr> </tbody> </table>	Name	Online value	Program0.Input_Start	True	Program0.Local_Status		Busy	False	Done	True	Error	False	Name	Online value	Program0.Input_Start	True	Program0.Local_Status		Busy	False	Done	False	Error	True
Name	Online value																								
Program0.Input_Start	True																								
Program0.Local_Status																									
Busy	False																								
Done	True																								
Error	False																								
Name	Online value																								
Program0.Input_Start	True																								
Program0.Local_Status																									
Busy	False																								
Done	False																								
Error	True																								
<p><b>2</b> If the program ends normally, check that each error code is "0".</p> <p>* If the program ends with an error, an error code will be stored according to the error that occurred. Take corrective action according to 9.8. "Error Processing".</p>	<p><b>[When it ends normally]</b></p> <table border="1"> <tbody> <tr> <td>Program0.Output_PmrErrorID</td> <td>0000</td> </tr> <tr> <td>Program0.Output_PmrErrorIDEx</td> <td>0000 0000</td> </tr> <tr> <td>Program0.Output_PmrStaErrCode</td> <td>0000</td> </tr> <tr> <td>Program0.Output_TransErrCode</td> <td>0000</td> </tr> </tbody> </table> <p><b>[When it ends with an error]</b></p> <table border="1"> <tbody> <tr> <td>Program0.Output_PmrErrorID</td> <td>0000</td> </tr> <tr> <td>Program0.Output_PmrErrorIDEx</td> <td>0000 0000</td> </tr> <tr> <td>Program0.Output_PmrStaErrCode</td> <td>0000</td> </tr> <tr> <td>Program0.Output_TransErrCode</td> <td>0010</td> </tr> </tbody> </table>	Program0.Output_PmrErrorID	0000	Program0.Output_PmrErrorIDEx	0000 0000	Program0.Output_PmrStaErrCode	0000	Program0.Output_TransErrCode	0000	Program0.Output_PmrErrorID	0000	Program0.Output_PmrErrorIDEx	0000 0000	Program0.Output_PmrStaErrCode	0000	Program0.Output_TransErrCode	0010								
Program0.Output_PmrErrorID	0000																								
Program0.Output_PmrErrorIDEx	0000 0000																								
Program0.Output_PmrStaErrCode	0000																								
Program0.Output_TransErrCode	0000																								
Program0.Output_PmrErrorID	0000																								
Program0.Output_PmrErrorIDEx	0000 0000																								
Program0.Output_PmrStaErrCode	0000																								
Program0.Output_TransErrCode	0010																								





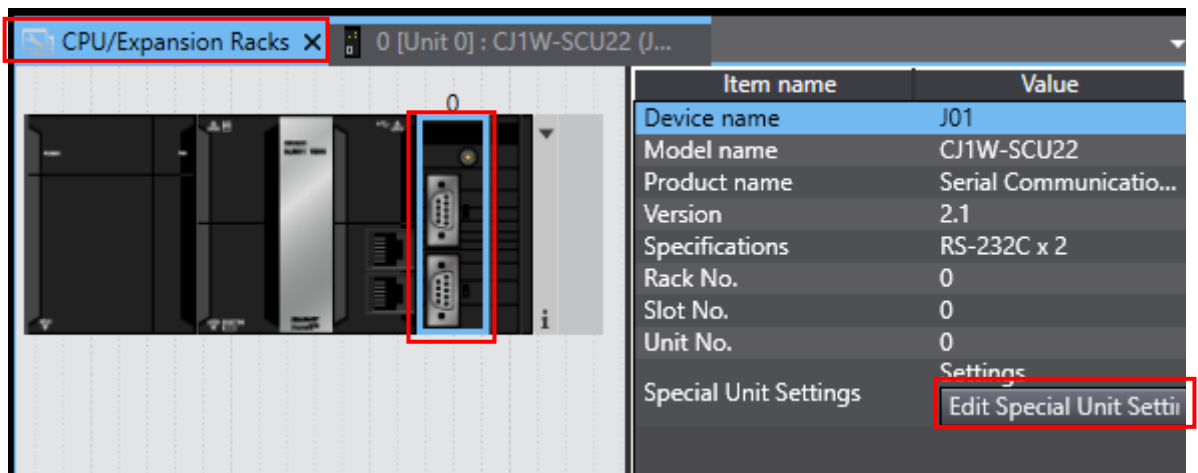

Select [Return to Default], select [Apply], and then execute [Transfer to Controller].

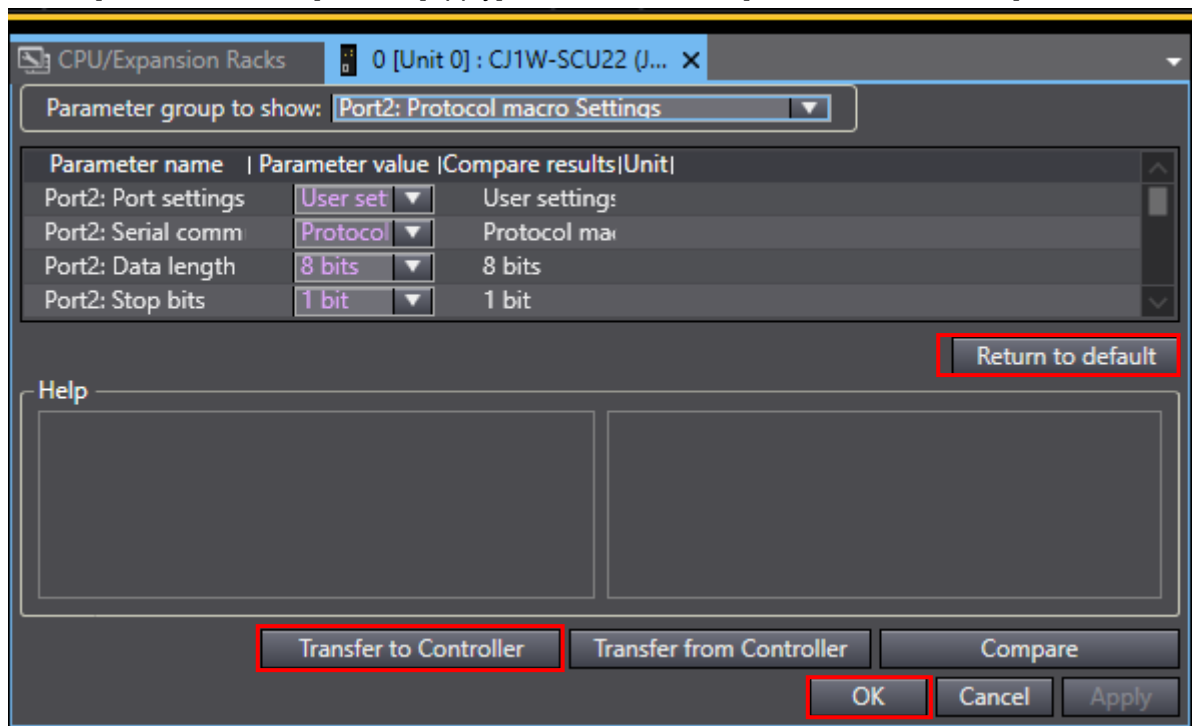

## CPU Unit

To return the controller to its original settings, from the Sysmac Studio menu bar select [Controller]—[Clear All Memory]. The [Clear All Memory] dialog is displayed. Confirm the contents and click [OK].

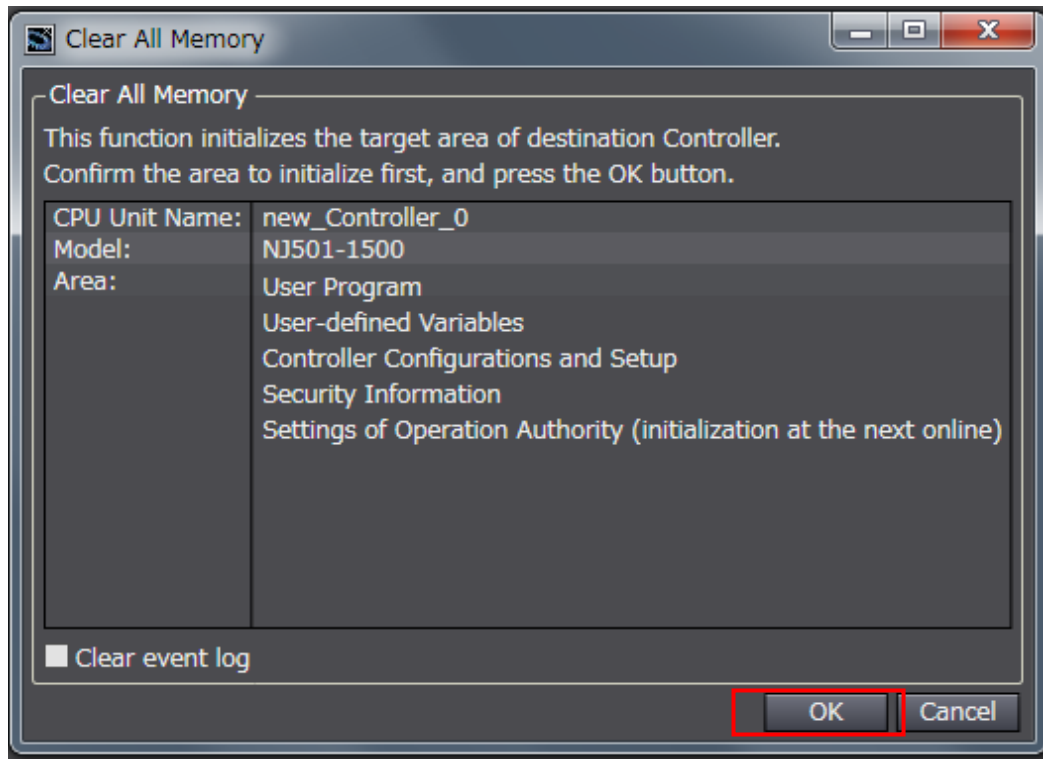

## 8.2. Initializing the Smart camera

For information on how to initialize a smart camera, consult our branch or sales office.

## 9. Program

Details of programs and protocol macro data used in this document are shown below.

### 9.1. Overview

---

This chapter describes the specifications and functions of the program and protocol macro data used to check the connection between the smart camera (hereafter, sometimes referred to as the partnering device) and the controller (Serial Communication Unit (hereinafter SCU unit)).

This program and protocol macro data use the protocol macro function of the SCU unit to send and receive "Serial Trigger" commands to and from the Partnering device to determine Normal/Abnormal termination.

The program's normal termination is the normal termination of the protocol macro's send / receive sequence.

Also, abnormal termination is considered as abnormal termination of the Send / Receive sequence of the protocol macro.

In this section, if it is necessary to distinguish between decimal data and hexadecimal data, add "10 #" (optional) to the beginning of decimal data and "16 #" to the beginning of hexadecimal data. (For example, "1000" or "10#1000" for decimal data, "16#03E8" for hexadecimal data)

To specify the data type, add "<data type> #" at the beginning. (For example, "WORD#16#03E8")



#### Note

---

This project file only confirms that communication is possible for this test configuration, product versions, and product lots used for evaluation.

Operation is not guaranteed under disturbances such as electrical noise or variations in the performance of the device itself.

---

### 9.1.1. Communication Data Flow

This is the flow from issuing command data from the controller (SCU unit) to the partnering device through serial communication and receiving response data from the partnering device.

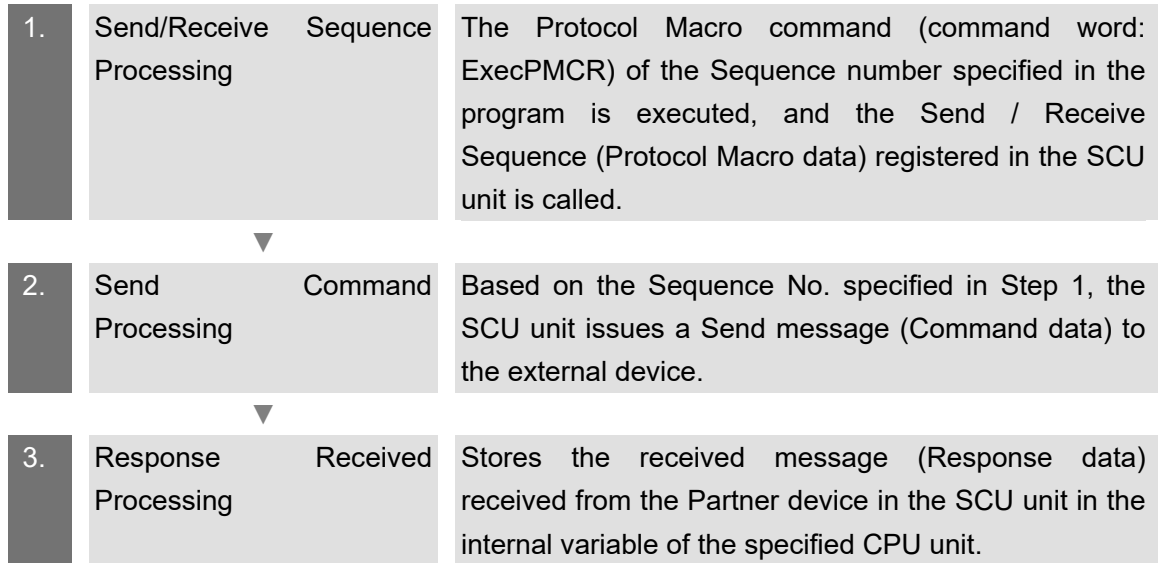

### 9.1.2. Function block for Protocol Macro execution and Send / Receive message

This section provides an overview of the Protocol Macro execution Function Block (hereafter, ExecPMCR instruction) and the general operation of Send / Receive messages.



#### Note

For details, refer to "Chapter 2 Instruction Descriptions" - "Serial Communication Instruction (Exec PMCR)" in the "Machine Automation Controller NJ/NX-series Instructions Reference Manual (W502)".

#### • ExecPMCR Instruction

This program uses the following standard instructions to implement Serial communication.

Name	Function Block	Description
Protocol Macro	ExecPMCR	Request the execution of the Send / Receive Sequence (Protocol data) registered in the SCU unit.

#### • ExecPMCR Instruction Data

Instruction	Name	FB/ FUN	Graphic expression	ST expression
ExecPMCR	Protocol Macro	FB		ExecPMCR_instance(Execute, Port, SeqNo, SrcDat, DstDat, Done, Busy, Error, ErrorID, ErrorIDEx);

#### Variables

Name	Meaning	I/O	Description	Valid range	Unit	Default
Port	Destination port	Input	Destination port	---	---	---
SeqNo	Communications sequence number		Communications sequence number	0 to 999		0
SrcDat[] (array)	Send data array		Send data array	Depends on data type.		*
DstDat[] (array)	Receive data array	In-out	Receive data array	Depends on data type.	---	---

\* If you omit the input parameter, the default value is not applied. A building error will occur.

- Partner device port specification "Port" data type (\_sPORT)

Name	Meaning	Description	Data type	Valid range	Unit	Default
Port	Destination port	Destination port	_sPORT	---	---	---
UnitNo	Unit number	Unit number of Serial Communications Unit	_eUnitNo	_CBU_No00 to _CBU_No15	---	_CBU_No00
PhysicPortNo	Serial port number	Serial port number on Serial Communications Unit	USINT	1 or 2	---	1

- Send/Receive Message

[Overview of Send and Receive messages]

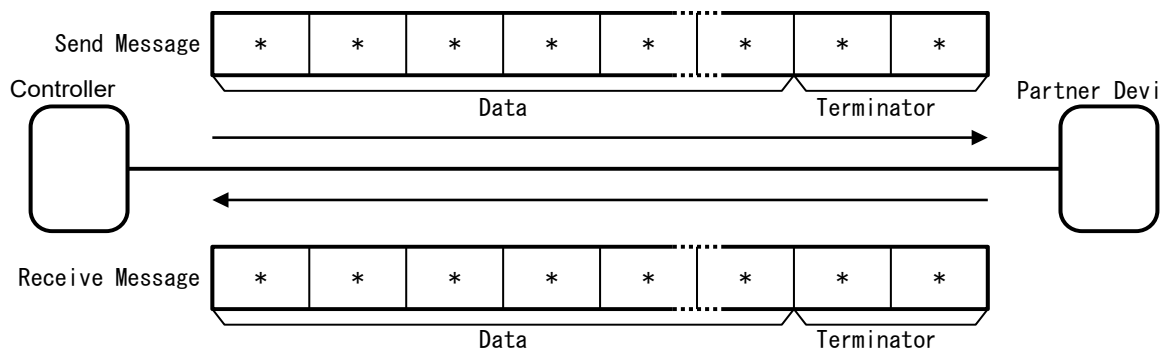

[Send data array: Relationship between SrcDat [ ] and Send message]

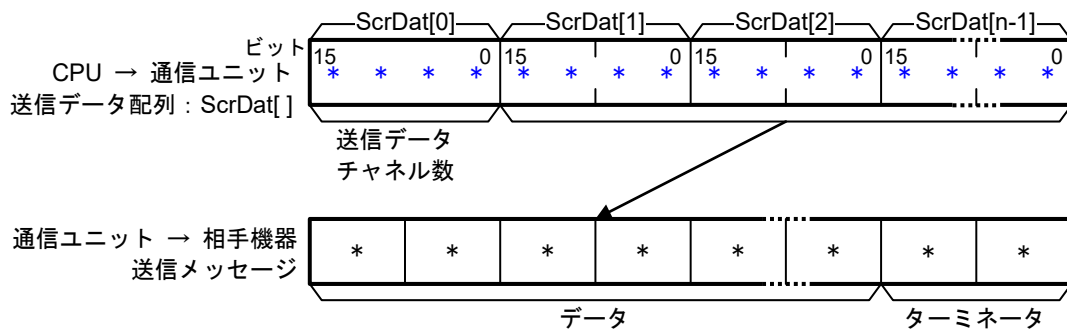

[Relationship between Receive message and Receive data array: DstDat [ ]]

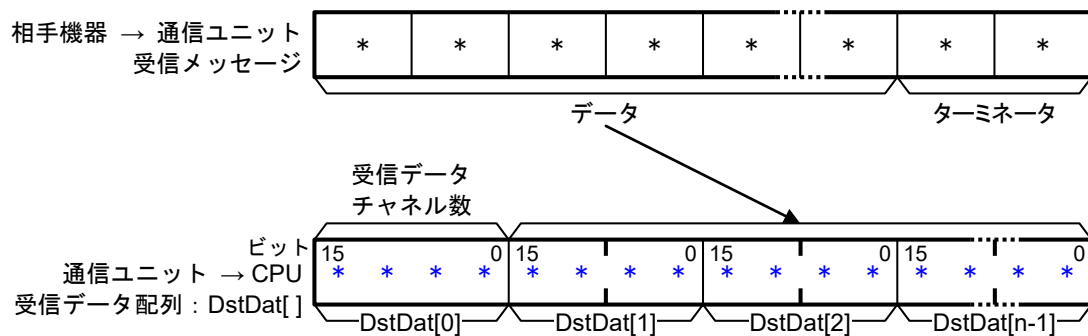



## 9.2. Send/Receive Sequence

This section describes the Send / Receive Sequence (Protocol Macro data) that can be used in the ExecPMCR instruction of this program.

### 9.2.1. Send/Receive Sequence No.

The Send / Receive Sequence (Protocol macro data) registered in the SCU unit is identified by the Send / Receive Sequence No. By specifying the Send / Receive Sequence No. with the ExecPMCR command, the Partner device's command is executed on the other device.

The following Send / Receive Sequences are prepared for this Protocol Macro data.

No.	Command name	Content
900	Serial Trigger	Issues a Serial (Inspection execution) trigger.

### 9.2.2. ExecPMCR instruction input variable setting

The settings of the ExecPMCR Instruction input variables for Send / Receive Sequence No. 900 "Serial Trigger" are as follows.

Variable	Name (Data type)	Data (Description)
Port	Partner device port specification ( _sPROT)	-
	UnitNo	Unit No.(_eUnitNo) _eUnitNo#_CBU_No00 {Specify SCU Unit No.}
	PhysicPortNo	Serial Port No. (USINT) USINT#10#2 (Use Serial Port No.2)
SeqNo	Send/Receive Sequence No. (UINT)	UINT#10#900 (Specify Serial trigger)
SrcDat[ ]Array	Send Data Array(WORD)	WORD#16#0000 (Number of Send data channels 0: Specifies that the command does not have required parameters)
DstDat[ ]Array	Rcv. Data Array(WORD)	(Since it is received data, no setting is required)

### 9.3. Error Judgment Processing

This program is divided into the following three ranges ① to ③ and performs Error Judgment processing. Refer to section 9.8. "Error Processing".

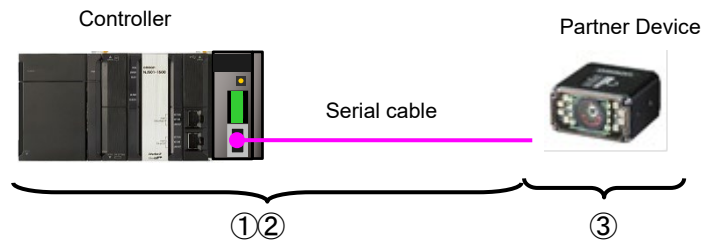

① Error during ExecPMCR instruction execution (ExecPMCR instruction error)

An error during ExecPMCR command execution, such as an error in the main unit or communication settings, is judged as "ExecPMCR command error". Judgment is made based on the "Error code (Error ID)" and "Expansion error code (Error IDEx)" of the ExecPMCR instruction.

② Error when executing protocol macro (Protocol Macro error)

When the protocol macro is terminated abnormally for some reason during execution, it is judged as "Protocol Macro error". Judgment is made by the sequence Abort end flag (J01\_P2\_PmrSeqAbtSta).

③ Partner device error (Remote device error)

An error such as a command error, parameter error, data error, or inexecution error on the Partner device is judged as a "Remote device error". Judgment is based on the response data returned from the other device. In this program, the response is not sent back from the other device at the time of an abnormality, so it is detected as a timeout error of ②.

Since the causes of the abnormalities ① and ② above may be related, all the following abnormal codes are stored when any of the abnormalities occurs.

- ExecPMCR Instruction error code (ErrorID)
- ExecPMCR Instruction expansion error code (ErrorIDEx)
- Protocol macro error code (lower 4 bits of J01\_P2\_PmrSta)
- Data transmission error status (J01\_P2\_TransErrSta)

## 9.4. Variables Used

Variables used in this program.

### 9.4.1. User-defined Variables

A list of data types, external variables (user-defined global variables / CJ unit device variables / system-defined variables), and internal variables used in this program.

- Data type (Structure)

[Communication process status flag]

Name	Data type	Description
sStatus	STRUCT	Communication processing status flag Structure
Busy	BOOL	Communication processing execution status TRUE: Executing / FALSE: Not executing
Done	BOOL	Communication processing normal end flag TRUE: Normal end / FALSE: Other than normal end
Error	BOOL	Communication processing abnormal end flag TRUE: Abnormal termination / FALSE: Other than abnormal termination

- External variables

[User-defined global variables]

Variable name	Data format	Description
Input_Start	BOOL	Communication start switch Start the program with "FALSE" → "TRUE"
Input_SendData	ARRAY[0..249] OF WORD	Send data storage area (WORD type 500 bytes)
Output_RecvData	ARRAY[0..249] OF WORD	Receive data storage area (WORD type 500 bytes) Area to store DstDat [ ] of ExecPMCR instruction
		Allocation destination %5500 (※)
Output_RecvMessage	STRING[498]	Received data storage area converted to character string (498 characters)
Output_PmrErrorID	WORD	ExecPMCR instruction error code storage area Normal end: 16#0000
Output_PmrErrorIDEx	DWORD	Exec PMCR instruction extended error code storage area Normal end: 16#00000000
Output_PmrStaErrCode	WORD	Protocol Macro Error Code storage area Normal end: 16#0000
Output_TransErrCode	WORD	Transmission error status flag storage area [J01_P2_TransErrSta] Storage area Normal end: 16#0000

\* For the area to store DstDat [ ] of ExecPMCR instruction, AT specification is required for the address of CJ unit memory.

[CJ unit device variable] (SCU unit)

Variable name	Data format	Description
J01_P2_PmrSta	WORD	Protocol Macro Execution status Bit 03 to 00: Protocol macro error code
J01_P2_PmrExecSta	BOOL	Protocol Macro Execution flag
J01_P2_PmrSeqEndSta	BOOL	Sequence End Completion Flag
J01_P2_PmrSeqAbtSta	BOOL	Sequence Abort Completion Flag
J01_P2_TransErrSta	WORD	Transmission error status



**Note**

For details on the SCU unit variables, refer to "2-3 Device Variable for CJ-series Unit" in "CJ-Series Serial Communication Unit Operation Manual for NJ-series CPU Unit" (W494).

[System-defined Variables]

Variable name	Data format	Description
_Port_isAvailable	BOOL	Network Communications Instruction Enabled Flag TRUE: A port is available. FALSE: A port is not available.



**Note**

For detailed information on System-defined variables used with the ExecPMCR instruction, refer to "Chapter 2 Instruction Descriptions" - "Serial Communication Instruction (ExecPMCR)" - "Related System-defined Variables" in the "Machine Automation Controller NJ/NX-series Instructions Reference Manual (W502)".

- Internal Variables (Instance variables)

This is a list of Internal variables for executing the Function Block in the program. This internal variable is called an "Instance", and the name of the function block to be used is specified in the variable data type.

Variable name	Data format	Description
ExecPMCR_instance	ExecPMCR	Request the execution of the Send / Receive Sequence (Protocol data) registered in the SCU unit.
F_TRIG_instance	F_TRIG	When the Input signal falls, TRUE is output for one task cycle.



**Note**

For details on ExecPMCR, refer to "Chapter 2 Instruction Descriptions" - "Serial Communication Instruction (ExecPMCR)" in the "Machine Automation Controller NJ/NX-series Instructions Reference Manual (W502)".



**Note**

For details on F\_TRIG Instruction, refer to "Chapter 2 Instruction Descriptions" - "Sequence Input Instructions (F\_TRIG)" in the "Machine Automation Controller NJ/NX-series Instructions Reference Manual (W502)".

- Internal Variable

Variable name	Data format	Description
Local_Status	sStatus	Communication processing status flag column Defined by structure type "sStatus"
Local_State	DINT	State processing number
Local_ExecFlgs	BOOL	Communication Instruction Initialization Flag
Local_EndExecPMCR	BOOL	Protocol macro execution end judgment flag
Local_InPort	_sPort	Specifies Port to use
Local_SeqNo	UINT	Send/Receive Sequence No.
Local_PmrStaCode	WORD	Protocol macro error code editing area
Local_RecvWordData	ARRAY[0..248] OF WORD	Area (498 bytes) for extracting and storing the part that converts the character string from the received data
Local_RecvWordSize	UINT	Data size of the data to be converted to a character string (unit: WORD)
Local_RecvByteData	ARRAY[0..497] OF BYTE	Area where the data to be converted to a character string is converted to a byte array (498 bytes)
Local_RecvByteSize	UINT	Data size of the data to be converted to a character string (unit: BYTE)

## 9.5. Functional Configuration of Program in ST Language

### 9.5.1.

This program is written in the ST language. The function configuration is as follows.

Major classification	Minor classification	Content
1. Communication processing	1.1. Communication processing start 1.2. Communication processing status flag column clear 1.3. Communication execution processing state and state transition processing	Start communication process.
2. Initialization processing	2.1. Initialize Communication Instruction 2.2. Initialize Communication Instruction Activation Flag 2.3. Error code storage area initialization 2.4. Setting the ExecPMCR Instruction Input Variable 2.5. Receive data storage area initialization 2.6. End initialization process	Set the parameters of the communication command (ExecPMCR Instruction) and clear the Receive data storage area.
3. PMCR Communication processing	3.1. Set Receive processing status and activation flag judgement 3.2. Receive Instruction activation	Execute ExecPMCR Instruction. Judge whether the execution result is normal or abnormal.
4. Processing number error processing	-	Execute error processing when a nonexistent processing number is detected.

## 9.5.2. Program List

The contents of this program.

- Program: Program0 (General-purpose serial communication connection confirmation program)

### 1. Communication processing

```
(* =====  
名称：NJシリーズ汎用シリアル(RS-232C)通信接続確認プログラム (7ポートマルチ機能使用)  
対象機器：オムロン株式会社 コトリーダ 形V430  
シリアルコミュニケーションユニット：CJ1W-SCU22 (7ポートマルチ機能使用,ユニット番号：0 シリアルポート番号：2)  
バージョン情報：V1.00 2019/5 新規  
(C)Copyright OMRON Corporation 2013 All Rights Reserved.  
===== *)
```

#### (\* 1. 通信処理

通信開始スイッチ：Input\_Start

通信処理ステータスフラグ列：Local\_Status<STRUCT>

.Busy：通信実行中 .Done：通信正常終了 .Error：通信異常終了

状態処理番号：Local\_State

10：初期処理 11：PMCR通信処理 \*)

#### (\* 1.1. 通信処理開始

通信処理ステータスフラグ列がクリアな状態で通信開始スイッチがONされた場合に通信処理を開始 \*)

IF Input\_Start AND

NOT (Local\_Status.Busy OR Local\_Status.Done OR Local\_Status.Error) THEN

Local\_Status.Busy:=TRUE;

Local\_State:=10; //10:初期処理へ

END\_IF;

#### (\* 1.2. 通信処理ステータスフラグ列クリア

通信処理非実行状態で通信開始スイッチOFFにより通信処理ステータスフラグ列クリア \*)

IF NOT Input\_Start AND NOT Local\_Status.Busy THEN

Local\_Status.Done:=FALSE;

Local\_Status.Error:=FALSE;

END\_IF;

#### (\* 1.3. 通信処理実行中状態となり各状態処理へ遷移 \*)

IF Local\_Status.Busy THEN

CASE Local\_State OF

## 2. Initialization processing

To change the input values such as SCU unit number, port number to be used, protocol macro sequence number, and transmission data size, change the items in the **red frame**.

### (\* 2. 初期処理

- ・通信全体の各種初期化とパラメータ設定
- ・送信データの設定と受信データ格納エリアの初期化 \*)

10:

(\* 2.1. 通信命令の初期化 \*)

```
ExecPMCR_instance(  
    Execute:=FALSE,  
    SrcDat:=Input_SendData[0],  
    DstDat:=Output_RecvData[0]);
```

(\* 2.2. 通信命令起動フラグ初期化 \*)

```
Local_ExecFlg:=FALSE;
```

(\* 2.3. I/Oポート格納エリアの初期化 \*)

```
Clear(Output_PmrErrorID); //ExecPMCR命令I/Oポート格納エリア  
Clear(Output_PmrErrorIDEx); //ExecPMCR命令拡張I/Oポート格納エリア  
Clear(Output_PmrStaErrCode); //°トコルマクI/Oポート格納エリア  
Clear(Output_TransErrCode); //伝送I/Oポート格納エリア
```

(\* 2.4. ExecPMCR命令入力変数設定 \*)

```
Local_InPort.UnitNo:=_eUnitNo#_CBU_No00; //SCUユニット番号  
Local_InPort.PhysicPortNo:=USINT#2; //物理ポート番号  
Local_SeqNo:=UINT#900; //°トコルマクシーケンス番号  
Input_SendData[0]:=WORD#0; //送信データサイズ (単位 : WORD)
```

(\* 2.5. 受信データ格納エリアの初期化 \*)

```
Clear(Output_RecvData); //ExecPMCR受信データ格納エリア  
Clear(Local_RecvWordData); //文字列変換用WORDエリア  
Clear(Local_RecvByteData); //文字列変換用BYTEエリア  
Clear(Output_RecvMessage); //文字列格納エリア
```

(\* 2.6. 初期設定終了処理 \*)

```
Local_State:=11; //11:PMCR通信処理へ
```



### 3. PMCR Communication Processing

#### (\* 3. PMCR通信処理

・指定したシリアルポートから通信処理実行 \*)

11:

(\* 3.1. 通信処理状況の判定と起動フラグセット \*)

(\* 3.1.1. 7°ポート追加実行終了時の正常/異常判定処理 \*)

F\_TRIG\_instance(J01\_P2\_PmrExecSta,Local\_EndExecPMCR); //7°ポート追加実行終了判定

IF Local\_EndExecPMCR THEN

IF NOT J01\_P2\_PmrSeqEndSta THEN //7°ポート追加異常終了

Output\_TransErrCode:=J01\_P2\_TransErrSta;

Local\_Status.Error:=TRUE;

ELSE

//正常終了処理

Output\_TransErrCode:=WORD#16#0000;

Local\_Status.Done:=TRUE;

//受信データの文字列変換

Local\_RecvWordSize:=WORD\_TO\_UINT(Output\_RecvData[0])-1;

MemCopy(Output\_RecvData[1],Local\_RecvWordData[0],Local\_RecvWordSize);

ToAryByte(Local\_RecvWordData,\_eBYTE\_ORDER#\_HIGH\_LOW,Local\_RecvByteData[0]);

Local\_RecvByteSize:=Local\_RecvWordSize\*2;

Output\_RecvMessage:=AryToString(Local\_RecvByteData[0],Local\_RecvByteSize);

END\_IF;

Local\_EndExecPMCR:=FALSE;

Local\_Status.Busy:=FALSE;

Local\_ExecFlg:=FALSE;

Local\_State:=0; //0: 通信非実行状態へ

(\* 3.1.2. 7°ポート追加実行中の異常判定処理 \*)

ELSIF ExecPMCR\_instance.Error THEN //ExecPMCR命令異常

Output\_PmrErrorID:=ExecPMCR\_instance.ErrorID;

Output\_PmrErrorIDEx:=ExecPMCR\_instance.ErrorIDEx;

MoveDigit(J01\_P2\_PmrSta,USINT#0,Local\_PmrStaCode,USINT#0,USINT#1);

Output\_PmrStaErrCode:=Local\_PmrStaCode;

Output\_TransErrCode:=J01\_P2\_TransErrSta;

Local\_Status.Busy:=FALSE;

Local\_Status.Error:=TRUE;

Local\_ExecFlg:=FALSE;

Local\_State:=0; //0: 通信非実行状態へ

(\* 3.1.3. 通信命令起動フラグセット \*)

ELSIF \_Port\_isAvailable AND

NOT J01\_P2\_PmrExecSta AND

NOT ExecPMCR\_instance.Busy THEN

Local\_ExecFlg:=TRUE;

END\_IF;

(\* 3.2. 通信命令実行 \*)

ExecPMCR\_instance(

Execute:=Local\_ExecFlg,

Port:=Local\_InPort,

SeqNo:=Local\_SeqNo,

SrcDat:=Input\_SendData[0],

DstDat:=Output\_RecvData[0]);

#### 4. Process No. Error Processing

##### (\* 4. 処理番号異常処理

・存在しない処理番号の異常処理 \*)

99:

Output\_TransErrCode:=WORD#16#0010;

Local\_Status.Busy:=FALSE;

Local\_Status.Error:=TRUE;

Local\_State:=0; //0: 通信非実行状態へ

ELSE

Local\_State:=99; //99: 処理番号異常処理へ

END\_CASE;

END\_IF;

## 9.6. (Protocol Macro Data)

The Protocol Macro Data has the components "Sequence", "Step", "Send / Receive Message", and "Receive matrix", and has the following structures.

- When the received message format is only one type per Step (one Send / Receive)
  - Set one Receive message and one Send message for each Step

Sequence No.900	Step No.00	Transmit Message 00	Receive Message 00
⋮			
Sequence No.xxx	Step No.yy	Transmit Message yy	Receive Message yy

xxx : Up to Max 999 / yy : Up to Max 15

- When the received message format is multiple types per Step (one Send / Receive)
  - Set Receive message / Send message matrix for each Step
  - Set several types of "cases" (received messages) for the Receive matrix

Sequence No.900	Step No.00	Transmit Message 00	<Receive Matrix>	
⋮			Case No.00	Receive Message 00
Sequence No.xxx	Step No.yy		Case No.zz	Receive Message zz

yy: Max 15                      zz: Max 14

Sequence No.xxx	xxx: Max 999	Case No.15 is automatically set	Case No.15	Other
-----------------	--------------	---------------------------------	------------	-------

### 9.6.1. Protocol Macro Data Configuration

With this protocol macro data, only one type of receive message (SD\_RDCODE) is used for the send message (SD\_RDCODE), so the receive matrix is not used and the configuration is as follows. For more information refer to section 9.6.6 "Setting Receive Message".

Sequence No.900	Step No.00	SD_RDCODE	RV_RDCODE
-----------------	------------	-----------	-----------

### 9.6.2. Protocol Macro Processing Steps

Processing steps for Protocol Macro.

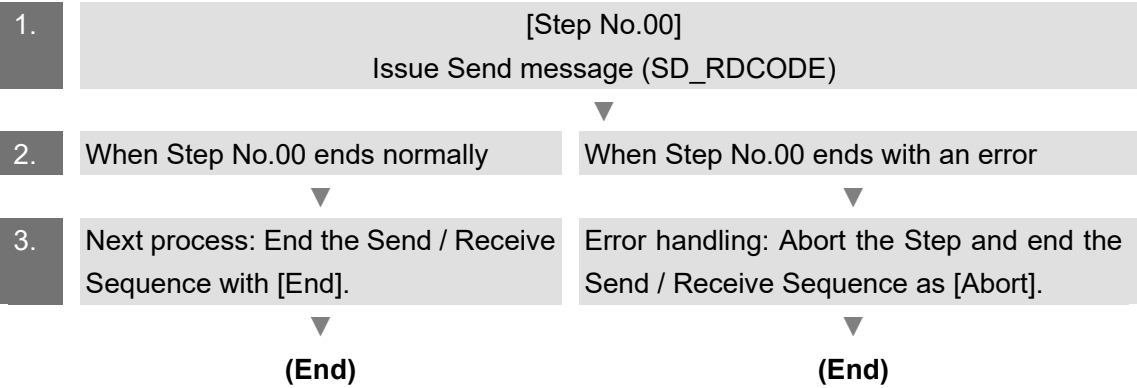

### 9.6.3. Sequence Settings

With this protocol macro data, Send / Receive Sequence No. 900 is used to perform a "read trigger" (read code). There is a "Timeout" setting item for the Send / Receive Sequence.



#### Note

For details on Sequence Settings, refer to "CX-Protocol Operation Manual" (W344).

- Setting the Timeout  
Setting the "Timeout time (Timer Tr, Tfr, Tfs)" for the sequence.

[Setting screen for Send / Receive sequence]

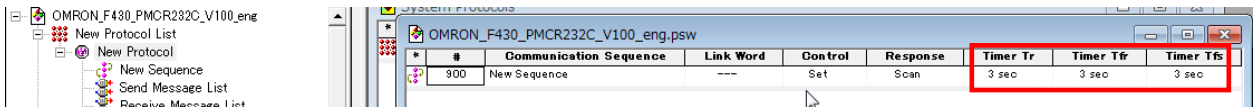

[Setting]

Item	Content	Description
Timer Tr	Monitoring time for Wait before Receive	At the step in the sequence, monitor the time from the reception wait state until the first data (header) is received. In this protocol macro data it is set to [3 seconds].
Timer Tfr	Monitoring time for Receive complete	At the steps in the sequence, monitor the time from the first data reception to the completion of reception. In this protocol macro data it is set to [3 seconds].
Timer Tfs	Monitoring time for Send complete	Monitor the time from sending the header to sending the last data. In this protocol macro data it is set to [3 seconds].



#### Note

For details on how to calculate the monitoring time, refer to the "CX-Protocol Operation Manual" (W344).

### 9.6.4. Step Settings

Setting the "Step" for Send / Receive sequence No.900. There are "Retry Count", "Send / Receive message (message name)", "Next process" and "Error handling" setting items for the Step. The sequence of this protocol macro data consists only of "Step No.00".



#### Note

For details on Step Settings, refer to Section 8 "Step Setting and Editing" in the "CX-Protocol Operation Manual" (W344).

- Set the Retry Count

Setting the "Retry Count" for the Step. When an error occurs, the Step is retried the specified number of times (0 to 9 times). As a result, if further error occurs, transition to "Error handling".

Retry count is valid only for Send & Receive command.

[Step setting screen]



[Setting]

Step No.	Retry Count
00	3

- Send/Receive Message (Message name) setting

Set the contents of "Send / Receive message" for the Step. The Send message name and Receive message name that are separately registered are set.

[Step setting screen]



[Setting]

Step No.	Send Message	Receive Message
00	SD_RDCODE	RV_RDCODE

- Next process and Error process settings

Settings for "Next process" and "Error process" for the Step. What is set for the "Next process" is executed when the Step execution is completed normally, and what is set for "Error process" are executed when a communication error occurs.

[Step setting screen]

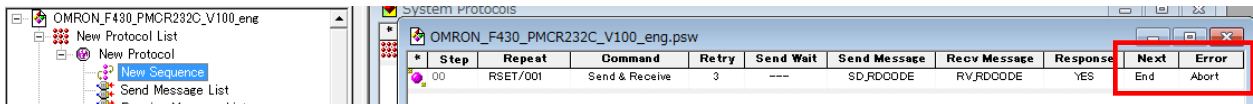

[Setting]

Step No.	Next Process	Error processing
00	End	Abort

[Processing items]

Processing	Content
End	Terminate Send/Receive Sequence
Next	Transitions to Next Step No.
Abort	Aborts the Step and terminates the Send/Receive sequence
Goto	Transitions to specified Step No.
Receive Matrix	According to the setting of "Receive matrix"

## 9.6.5. Setting the Send Message

Set the content of the Send Message



### Note

For details on setting the content of the Send Message, refer to “Section 9 Setting and Editing Messages and Matrix List” in "CX-Protocol Operation Manual" (W344).

[The Send Message Setting Screen]

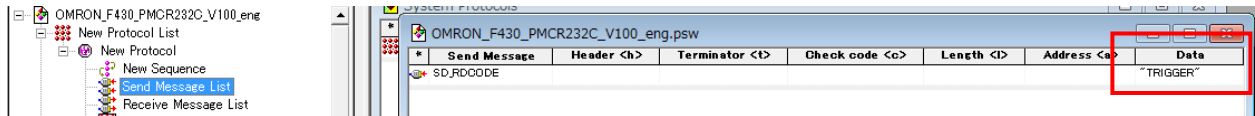

- Set the Send Message “SD\_RDCODE”

[Setting]

### TRIGGER

①

No.	Code	Content
②	"TRIGGER"	ASCII (Constant)

\* Set both Header <h> and Footer <f> to [None].

[Send Message Command Format]

This is the command format of the message sent from the SCU unit to the external device according to the "SD\_RDCODE" setting.

"TRIGGER"

Command	Bytes	Note
"TRIGGER"	1	Fixed: "TRIGGER" (16#54524947474552) (Partner device command "Serial Trigger")



## 9.6.6. Setting the Receive Message

Set the content of the Receive Message



### Note

For details on setting the content of the Receive Message, refer to "Section 9 Setting and Editing Messages and Matrix List" in "CX-Protocol Operation Manual" (W344).

[The Receive Message Setting Screen]

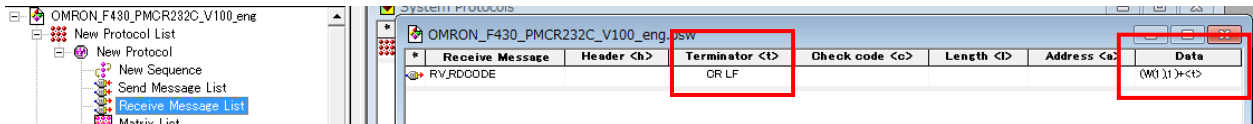

- Set the Receive Message "RV\_RDCODE"

[Setting]

(W(1,\*)+<t>

①    ②

No.	Code	Content
①	(W(1,*)	Message Data: Variable All variable-length data is fetched and stored in the array variable [n]+[1]th array element specified in "DstDat" of ExecPMCR instruction and after (in this program, Output_RecvData [1] ...)
②	<t>(Terminator)	Message data: Constant Hex, Type: Code, Data: CR LF

\* Header <h> is set to [None].

[Response format of Receive Message]

This is the Response format of the "Receive Message" from the Partner device that the SCU unit receives according to the "RV\_RDCODE" setting.

+ Inspection result	<CR><LF>
---------------------	----------

Command	Bytes	Note
Data	Variable length	Variable: Inspection result
Terminator	1	Fixed: <CR> <LF>(16#0D0A)

## 9.7. Timing Chart

The Timing Chart for the Program.

The definition of the timing chart pattern is as follows.

Pattern	Normal End	Abnormal Termination ① ExecPMCR Instruction Error	Abnormal Termination ② Protocol Macro Error
Command	Normal	Abnormal	Abnormal
Partner Device	Normal	Normal or Abnormal	Normal or Abnormal
Response	Yes	NO	No

### • Normal Termination

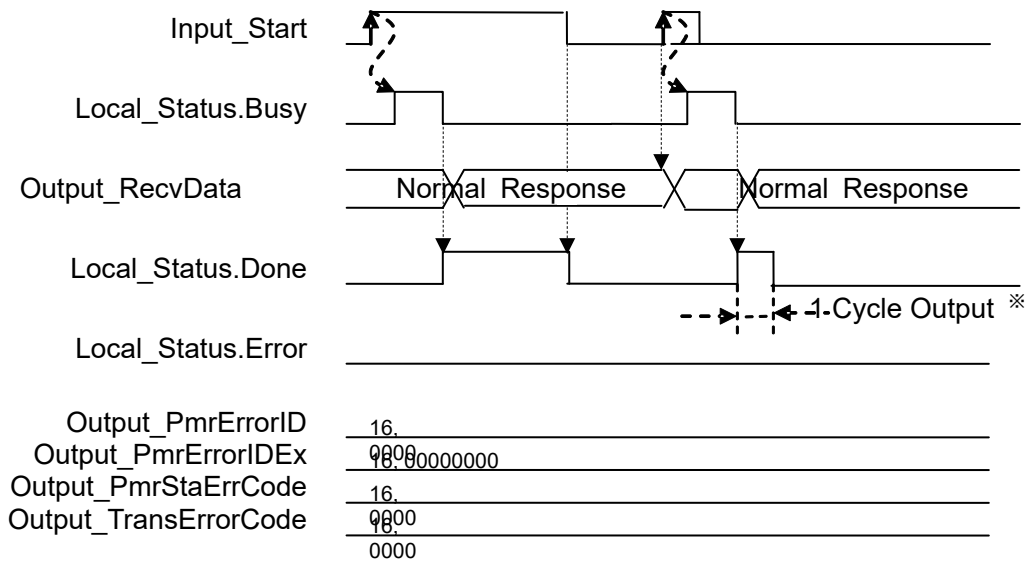

### • Abnormal Termination ①②

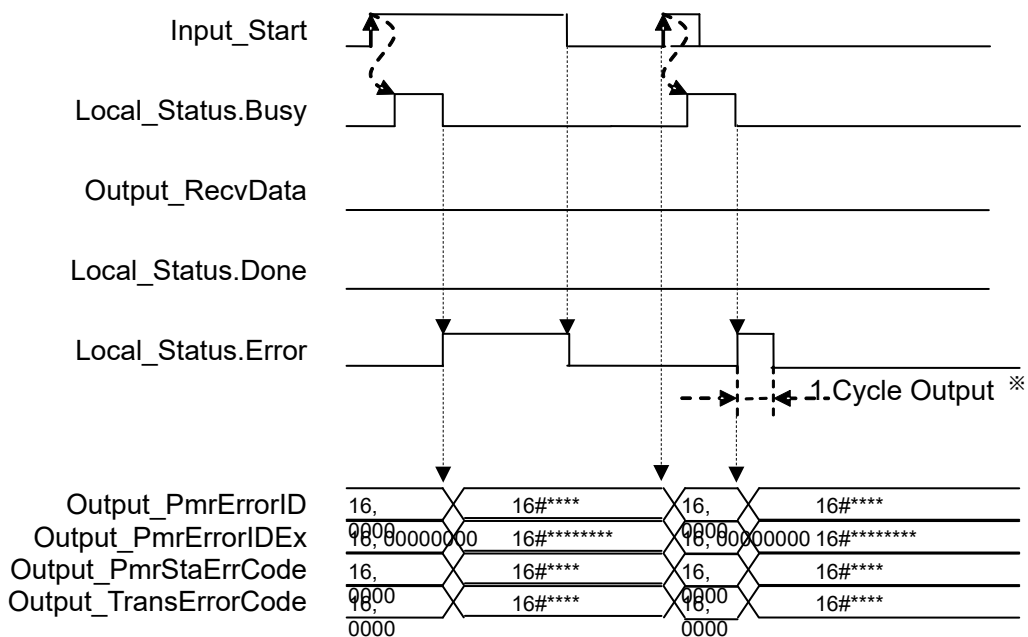

\* If [Input\_Start] changes from "TRUE" to "FALSE" during execution (Busy=TRUE), the 1 Cycle output of either Normal or Error is output after the processing is completed

(Busy=FALSE).

## 9.8. Error Process

The list below are the error codes that can occur when this program is executed.

### 9.8.1. ExecPMCR Instruction Error

Error code that occurs when the ExecPMCR instruction ends abnormally.

- Output\_PmrErrorID

After ExecPMCR is executed, the content of [ExecPMCR\_instance.ErrorID] is set.

Code	Content
16, 0000	Normal End
16, 0400	The input parameter of the instruction is out of the range of the input variable.
16, 0406	The memory address or data size of the data specified by the instruction is incorrect.
16, 0407	The results of instruction processing exceeded the data area range of the output parameter.
16, 0800	An error occurred in Send / Receive of FINS Instruction.
16, 0801	FINS port is in use.



#### Note

For details on ErrorID, see the following Appendices in "Machine Automation Controller NJ-series Instructions Reference Manual" (W502): "A-1 Error Codes That You Can Check with ErrorID", "A-2 Error Codes", "A-3 Instructions You Cannot Use in Event Tasks".

- Output\_PmrErrorIDEx

When the value of [ExecPMCR\_instance.ErrorID] is "16#0800", the content of [ExecPMCR\_instance.ErrorIDEx] is set.

Code	Content
16, 00000000	Normal End
16, 00001106	The value of "SeqNo" is the Send / Receive sequence number that has not been registered.
16, 00002201	This command is already being executed. The values of "Busy" and "J01_P2_PmrExecSta" are TRUE.
16, 00002202	Cannot execute because the protocol is being switched.
16, 00002401	The protocol macro data has an incorrect sum value, or data is being transferred.



#### Note

For details on ErrorIDEx, refer to "Chapter 2 Instruction Descriptions" - "Serial Communication Instruction (ExecPMCR)" in the "Machine Automation Controller NJ/NX-series Instructions Reference Manual (W502)".

### 9.8.2. Protocol Macro Error Codes

These are the Protocol Macro error code when an error caused by the Protocol Macro occurs. Set in [Output\_PmrStaErrCode].

- Output\_PmrStaErrCode

The contents of the lower 4 bits of [J01\_P2\_PmrSta] are set.

Code	Content
16, 0000	No Error
16, 0002	Sequence No. Error
16, 0003	Data Read/Write Area exceeded Error
16, 0004	Protocol Data Syntax Error



#### Note

For details on the Protocol Macro Error Code (PmrStaErrCode), refer to "4-2-6 Protocol Status" in "CJ-Series Serial Communication Unit Operation Manual for NJ-series CPU Unit" (W494).

### 9.8.3. Transmission error status

This is the error flag string when a transmission error occurs. Set in [Output\_TransErrCode].

- Output\_TransErrCode

The content of [J01\_P2\_TransErrSta] is set.

Bit	Content
15	1: Transmission error occurred    0: No transmission error occurred
14	1: Transmission completion monitoring time exceeded    0: Normal
13	1: Receive finish monitoring time over    0: Normal
12	1: Receive Wait Monitoring Time Over    0: Normal
8 to 11	Retry Count
7	1 : FCS Check Error    0 : Normal
6	1: Command error    0: Normal
5	1: Timeout    0: Normal
4	1: Overrun error occurred    0: Normal
3	1: Framing error occurred    0: Normal
2	1: Parity error    0: Normal
0, 1	(Not used)



#### Note

For details of Transmission error status (TransErrCode), refer to "4-2-5 Device Variables for CJ-series Unit for Status" in "CJ-Series Serial Communication Unit Operation Manual for NJ-series CPU Unit" (W494).

## 10. Revision History

Revision Symbol	Date of revision	Revised page and reason for revision
01	April 2022	First Publication



**OMRON Corporation** Industrial Automation Company  
Kyoto, JAPAN

Contact: [www.ia.omron.com](http://www.ia.omron.com)

**Regional Headquarters**

**OMRON EUROPE B.V.**

Wegalaan 67-69, 2132 JD Hoofddorp  
The Netherlands

Tel: (31)2356-81-300/Fax: (31)2356-81-388

**OMRON ASIA PACIFIC PTE. LTD.**

438B Alexandra Road, #08-01/02 Alexandra  
Technopark, Singapore 119968

Tel: (65) 6835-3011/Fax: (65) 6835-2711

**OMRON ELECTRONICS LLC**

2895 Greenspoint Parkway, Suite 200  
Hoffman Estates, IL 60169 U.S.A.

Tel: (1) 847-843-7900/Fax: (1) 847-843-7787

**OMRON (CHINA) CO., LTD.**

Room 2211, Bank of China Tower,  
200 Yin Cheng Zhong Road,  
PuDong New Area, Shanghai, 200120, China

Tel: (86) 21-5037-2222/Fax: (86) 21-5037-2200

Authorized Distributor:

© OMRON Corporation 2022 All Rights Reserved.  
In the interest of product improvement,  
specifications are subject to change without notice.

Cat. No. Z442-E-01

0622 (0422)