



Vision Sensor  
FH Series  
**Vision System**

---

**Hardware Setup Manual for 3D Robot Vision**

**FH-5050**  
**FH-SMDA-GS050B**



## NOTE

- All rights reserved.
- No part of this publication may be reproduced, stored in a retrieval system, or transmitted, in any form, or by any means, mechanical, electronic, photocopying, recording, or otherwise, without the prior written permission of OMRON.
- No patent liability is assumed with respect to the use of the information contained herein. Moreover, because OMRON is constantly striving to improve its high-quality products, the information contained in this manual is subject to change without notice. Every precaution has been taken in the preparation of this manual. Nevertheless, OMRON assumes no responsibility for errors or omissions.

Neither is any liability assumed for damages resulting from the use of the information contained in this publication.

## Trademarks

- Sysmac and SYSMAC are trademarks or registered trademarks of OMRON Corporation in Japan and other countries for OMRON factory automation products.
- This software is based in part on the work of the Independent JPEG Group.
- Microsoft, Windows, Windows Vista, Excel, and Visual Basic are either registered trademarks or trademarks of Microsoft Corporation in the United States and other countries.
- Intel, Core and Pentium are trademarks of Intel Corporation in the U.S. and/or other countries.
- EtherCAT® is registered trademark and patented technology, licensed by Beckhoff Automation GmbH, Germany.
- ODVA, CIP, CompoNet, DeviceNet, and EtherNet/IP are trademarks of ODVA.
- The SD, SDHC, microSD, and microSDHC logos are trademarks of SD-3C, LLC.



- QR Code is a registered trademark of DENSO WAVE INCORPORATED.
- MELSEC is a registered trademarks of Mitsubishi Electric Corporation.

Other company names and product names in this document are the trademarks or registered trademarks of their respective companies.

## Copyrights

Microsoft product screen shots used with permission from Microsoft.

# Introduction

---

Thank you for purchasing the FH Series.

This manual contains information that is necessary to use the FH Series.

Please read this manual and make sure you understand the functionality and performance of the FH Series before you attempt to use it in a control system.

Keep this manual in a safe place where it will be available for reference during operation.

## Intended Audience

This manual is intended for the following personnel, who must also have knowledge of electrical systems (an electrical engineer or the equivalent).

- Personnel in charge of introducing FA systems.
- Personnel in charge of designing FA systems.
- Personnel in charge of installing and maintaining FA systems.
- Personnel in charge of managing FA systems and facilities.

## Applicable Products

This manual covers the following products.

- FH-5050, FH-SMDA-GS050B  
FH-5050-10 and FH-5050-20 are not applicable.

Part of the specifications and restrictions are given in other manuals. Refer to Relevant Manuals on *Related Manuals* on page 29.

# Manual Structure

## Page Structure

The following page structure is used in this manual.

The diagram illustrates the structure of a manual page. It shows a page with a grey header bar containing the text "4 Installation and Wiring". Below this is a section header "4-3 Mounting Units". Underneath is a sub-section header "4-3-1 Connecting Controller Components". The main body of the page contains a procedure with two numbered steps. Step 1 includes a diagram of units with labels for "Hook", "Connector", and "Hook holes". Step 2 includes a diagram of a slider with labels for "Release", "Lock", and "Slider". Below the procedure is a "Precautions for Correct Use" section with a warning icon and text. At the bottom of the page, there is a footer with the text "NJ-series CPU Unit Hardware User's Manual (W500)" and the page number "4-9".

Annotations on the left side of the diagram:

- Level 2 heading:** Points to the "4-3 Mounting Units" header.
- Level 3 heading:** Points to the "4-3-1 Connecting Controller Components" header.
- A step in a procedure:** Points to the number "1" in the first step.
- Indicates a procedure:** Points to the first step's text.
- Special information:** Points to the "Precautions for Correct Use" section.
- Manual name:** Points to the footer text "NJ-series CPU Unit Hardware User's Manual (W500)".

Annotations on the right side of the diagram:

- Level 1 heading:** Points to the "4 Installation and Wiring" header.
- Level 2 heading:** Points to the "4-3 Mounting Units" header.
- Level 3 heading:** Points to the "4-3-1 Connecting Controller Components" header.
- Gives the current headings:** Points to the three level headings.
- Page tab:** Points to the "4" tab on the right edge of the page.
- Gives the number of the main section:** Points to the "4" tab.

**Note** This illustration is provided only as a sample. It may not literally appear in this manual.

## Special Information

Special information in this manual is classified as follows:



### **Precautions for Safe Use**

---

Precautions on what to do and what not to do to ensure safe usage of the product.



### **Precautions for Correct Use**

---

Precautions on what to do and what not to do to ensure proper operation and performance.



### **Additional Information**

---

Additional information to read as required.

This information is provided to increase understanding or make operation easier.



# Sections in This Manual

---

<b>1</b>	<b>Confirm the Package</b>	<b>1</b>
<b>2</b>	<b>Overview of FH series</b>	<b>2</b>
<b>3</b>	<b>Configuration</b>	<b>3</b>
<b>4</b>	<b>Handling and Installation Environment</b>	<b>4</b>
<b>5</b>	<b>Setup and Wiring</b>	<b>5</b>
<b>6</b>	<b>I/O Interface</b>	<b>6</b>
<b>I</b>	<b>Index</b>	<b>I</b>

# CONTENTS

<b>Introduction .....</b>	<b>1</b>
Intended Audience .....	1
Applicable Products .....	1
<b>Manual Structure.....</b>	<b>2</b>
Page Structure .....	2
Special Information .....	3
<b>Sections in This Manual .....</b>	<b>5</b>
<b>Terms and Conditions Agreement.....</b>	<b>9</b>
Warranty, Limitations of Liability .....	9
Application Considerations .....	10
Disclaimers .....	10
<b>Safety Precautions.....</b>	<b>12</b>
Symbols and the Meanings for Safety Precautions Described in This Manual .....	12
Meanings of Alert Symbols .....	12
Warning.....	13
<b>Precautions for Safe Use .....</b>	<b>17</b>
Condition of the Fitness of OMRON Products .....	17
Installation Environment (FH-5050) .....	17
Power Supply and Wiring (FH-5050) .....	17
Grounding (FH-5050).....	18
Others (FH-5050).....	18
Installation Environment (FH-SMDA-GS050B).....	19
Power Supply and Wiring (FH-SMDA-GS050B).....	19
Mounting (FH-SMDA-GS050B) .....	20
Others (FH-SMDA-GS050B) .....	20
Camera Calibration Target (FH-XCAL-S) .....	20
HandEye Calibration Target (FH-XCAL-R) .....	21
<b>Precautions for Correct Use .....</b>	<b>22</b>
Installation and Storage Sites (FH-5050).....	22
Orientation of Product (FH-5050) .....	22
Ambient Temperature (FH-5050) .....	22
Component Installation and Handling (FH-5050) .....	22
Maintenance (FH-5050).....	23
Communications with Upper Device (FH-5050) .....	23
Failsafe Measures (FH-5050).....	23
Connecting the Sensor Controller and Monitor with a Switcher and Splitter .....	23
Installation Location (FH-SMDA-GS050B) .....	24
Power Supply, Connection, and Wiring (FH-SMDA-GS050B).....	24
Maintenance (FH-SMDA-GS050B).....	24
Optical axis (FH-SMDA-GS050B).....	24
Image Sensor (FH-SMDA-GS050B).....	25
Failsafe Measures (FH-SMDA-GS050B).....	25
Warm-up (FH-SMDA-GS050B).....	25
Camera Installation (FH-SMDA-GS050B) .....	25
Connection and Operation with the Robot (FH-SMDA-GS050B) .....	25
LED Safety (FH-SMDA-GS050B) .....	25
Camera Calibration Target (FH-XCAL-S) .....	26
HandEye Calibration Target (FH-XCAL-R) .....	26
<b>Regulations and Standards .....</b>	<b>27</b>
FH-5050 .....	27



FH-SMDA-GS050B.....	28
<b>Related Manuals.....</b>	<b>29</b>
<b>Revision History.....</b>	<b>31</b>

## Section 1 Confirm the Package

<b>1-1 Sensor Controller.....</b>	<b>1-2</b>
1-1-1 FH-5050 .....	1-2
<b>1-2 3D Cameras and Related.....</b>	<b>1-3</b>
1-2-1 Camera .....	1-3
1-2-2 Camera Cable .....	1-3
1-2-3 Camera I/O Cable .....	1-3
<b>1-3 FH Application Software .....</b>	<b>1-4</b>
<b>1-4 Calibration Target .....</b>	<b>1-5</b>
<b>1-5 Sold Separately.....</b>	<b>1-6</b>
1-5-1 Monitor .....	1-6
1-5-2 Lighting and Lighting Controller .....	1-7
1-5-3 Accessories.....	1-7
1-5-4 Cable.....	1-8

## Section 2 Overview of FH series

<b>2-1 Basic System of Measurement.....</b>	<b>2-2</b>
2-1-1 System Configuration .....	2-4
<b>2-2 Flow of Use Procedure .....</b>	<b>2-5</b>

## Section 3 Configuration

<b>3-1 Sensor Controller.....</b>	<b>3-2</b>
3-1-1 FH-5050 .....	3-2
<b>3-2 Camera and Cables.....</b>	<b>3-9</b>
3-2-1 3D Vision Sensor.....	3-9
3-2-2 Camera Cable .....	3-13
3-2-3 Camera I/O Cable .....	3-17
<b>3-3 Calibration Target .....</b>	<b>3-19</b>
<b>3-4 Touch Panel Monitor and Cable .....</b>	<b>3-21</b>
<b>3-5 LCD and Cable .....</b>	<b>3-27</b>

## Section 4 Handling and Installation Environment

<b>4-1 FH-5050.....</b>	<b>4-2</b>
-------------------------	------------

## Section 5 Setup and Wiring

<b>5-1 When turning ON and OFF.....</b>	<b>5-2</b>
5-1-1 FH-5050 .....	5-2
<b>5-2 Fail-Safe Measures .....</b>	<b>5-4</b>

<b>5-3</b>	<b>Sensor Controller Installation.....</b>	<b>5-5</b>
5-3-1	FH-5050 .....	5-5
<b>5-4</b>	<b>Setup Touch Panel Monitor or Monitor.....</b>	<b>5-10</b>
5-4-1	FH-5050 .....	5-10
<b>5-5</b>	<b>Camera Installation.....</b>	<b>5-11</b>
5-5-1	FH-5050 .....	5-11
5-5-2	Installation of 3D Vision Sensor .....	5-12
<b>5-6</b>	<b>Insert/Remove SD Memory Card or USB Flash Drive.....</b>	<b>5-17</b>
5-6-1	FH-5050 .....	5-17
<b>5-7</b>	<b>Use by Connecting Software .....</b>	<b>5-18</b>
5-7-1	Simulation Software .....	5-18
<b>5-8</b>	<b>Installation in a Control Panel .....</b>	<b>5-19</b>
5-8-1	FH-5050 .....	5-19

## Section 6 I/O Interface

---

<b>6-1</b>	<b>Parallel Interface .....</b>	<b>6-2</b>
6-1-1	FH-5050 .....	6-2
<b>6-2</b>	<b>EtherCAT Interface.....</b>	<b>6-11</b>
6-2-1	FH-5050 .....	6-11
<b>6-3</b>	<b>Ethernet Interface .....</b>	<b>6-13</b>
6-3-1	FH-5050 .....	6-13

## Index

---

# Terms and Conditions Agreement

---

## Warranty, Limitations of Liability

### Warranties

---

#### ● Exclusive Warranty

Omron's exclusive warranty is that the Products will be free from defects in materials and workmanship for a period of twelve months from the date of sale by Omron (or such other period expressed in writing by Omron). Omron disclaims all other warranties, express or implied.

#### ● Limitations

OMRON MAKES NO WARRANTY OR REPRESENTATION, EXPRESS OR IMPLIED, ABOUT NON-INFRINGEMENT, MERCHANTABILITY OR FITNESS FOR A PARTICULAR PURPOSE OF THE PRODUCTS. BUYER ACKNOWLEDGES THAT IT ALONE HAS DETERMINED THAT THE PRODUCTS WILL SUITABLY MEET THE REQUIREMENTS OF THEIR INTENDED USE.

Omron further disclaims all warranties and responsibility of any type for claims or expenses based on infringement by the Products or otherwise of any intellectual property right.

#### ● Buyer Remedy

Omron's sole obligation hereunder shall be, at Omron's election, to (i) replace (in the form originally shipped with Buyer responsible for labor charges for removal or replacement thereof) the non-complying Product, (ii) repair the non-complying Product, or (iii) repay or credit Buyer an amount equal to the purchase price of the non-complying Product; provided that in no event shall Omron be responsible for warranty, repair, indemnity or any other claims or expenses regarding the Products unless Omron's analysis confirms that the Products were properly handled, stored, installed and maintained and not subject to contamination, abuse, misuse or inappropriate modification. Return of any Products by Buyer must be approved in writing by Omron before shipment. Omron Companies shall not be liable for the suitability or unsuitability or the results from the use of Products in combination with any electrical or electronic components, circuits, system assemblies or any other materials or substances or environments. Any advice, recommendations or information given orally or in writing, are not to be construed as an amendment or addition to the above warranty.

See <http://www.omron.com/global/> or contact your Omron representative for published information.

### Limitation on Liability; Etc

---

OMRON COMPANIES SHALL NOT BE LIABLE FOR SPECIAL, INDIRECT, INCIDENTAL, OR CONSEQUENTIAL DAMAGES, LOSS OF PROFITS OR PRODUCTION OR COMMERCIAL LOSS IN ANY

WAY CONNECTED WITH THE PRODUCTS, WHETHER SUCH CLAIM IS BASED IN CONTRACT, WARRANTY, NEGLIGENCE OR STRICT LIABILITY.

Further, in no event shall liability of Omron Companies exceed the individual price of the Product on which liability is asserted.

## Application Considerations

### Suitability of Use

Omron Companies shall not be responsible for conformity with any standards, codes or regulations which apply to the combination of the Product in the Buyer's application or use of the Product. At Buyer's request, Omron will provide applicable third party certification documents identifying ratings and limitations of use which apply to the Product. This information by itself is not sufficient for a complete determination of the suitability of the Product in combination with the end product, machine, system, or other application or use. Buyer shall be solely responsible for determining appropriateness of the particular Product with respect to Buyer's application, product or system. Buyer shall take application responsibility in all cases.

NEVER USE THE PRODUCT FOR AN APPLICATION INVOLVING SERIOUS RISK TO LIFE OR PROPERTY OR IN LARGE QUANTITIES WITHOUT ENSURING THAT THE SYSTEM AS A WHOLE HAS BEEN DESIGNED TO ADDRESS THE RISKS, AND THAT THE OMRON PRODUCT(S) IS PROPERLY RATED AND INSTALLED FOR THE INTENDED USE WITHIN THE OVERALL EQUIPMENT OR SYSTEM.

### Programmable Products

Omron Companies shall not be responsible for the user's programming of a programmable Product, or any consequence thereof.

## Disclaimers

### Performance Data

Data presented in Omron Company websites, catalogs and other materials is provided as a guide for the user in determining suitability and does not constitute a warranty. It may represent the result of Omron's test conditions, and the user must correlate it to actual application requirements. Actual performance is subject to the Omron's Warranty and Limitations of Liability.

### Change in Specifications

Product specifications and accessories may be changed at any time based on improvements and other reasons. It is our practice to change part numbers when published ratings or features are changed, or when significant construction changes are made. However, some specifications of the Product may

be changed without any notice. When in doubt, special part numbers may be assigned to fix or establish key specifications for your application. Please consult with your Omron's representative at any time to confirm actual specifications of purchased Product.

## **Errors and Omissions**

---



Information presented by Omron Companies has been checked and is believed to be accurate; however, no responsibility is assumed for clerical, typographical or proofreading errors or omissions.

# Safety Precautions







## Symbols and the Meanings for Safety Precautions Described in This Manual

The following notation is used in this manual to provide precautions required to ensure safe usage of a Sensor Controller. The safety precautions that are provided are extremely important to safety. Always read and heed the information provided in all safety precautions.

The following notation is used.

 <b>WARNING</b>	<p>Indicates a potentially hazardous situation which, if not avoided, will result in minor or moderate injury, or may result in serious injury or death.</p> <p>Additionally there may be significant property damage.</p>
 <b>Caution</b>	<p>Indicates a potentially hazardous situation which, if not avoided, may result in minor or moderate injury or in property damage.</p>

## Meanings of Alert Symbols

	<p><b>General Prohibition</b> Indicates general prohibitions, including warnings, for which there is no specific symbol</p>
	<p><b>General Caution</b> Indicates general cautions, including warnings, for which there is no specific symbol.</p>
	<p>The filled circle symbol indicates operations that you must do. The specific operation is shown in the circle and explained in text. This example shows a general precaution for something that you must do.</p>
	<p><b>Electrical Hazard</b> Indicates the possible danger of electric shock under specific conditions.</p>
	<p><b>Explosion Hazard</b> Indicates the possible danger of explosion under specific conditions.</p>
	<p><b>LED light Hazard</b> Indicates the possible danger of LED radiation or light.</p>
	<p><b>High Temperature Caution</b> Indicates the possible danger of injury by high temperature under specific conditions.</p>

## Warning

**WARNING**

This product must be used according to this manual and Instruction Sheet. Failure to observe this may result in the impairment of functions and performance of the product.



This product is not designed or rated for ensuring the safety of persons. Do not use it for such purposes.



Never connect the AC power supply with this product. When the AC power supply is connected, it causes the electric shock and a fire.



A lithium battery is built into the Controller and may occasionally combust, explode, or burn if not treated properly. Dispose of the Controller as industrial waste, and never disassemble, apply pressure that would deform, heat to 100°C or higher, or incinerate the Controller.



If you keep watching the LED light, it may have an adverse effect on the eyes, do not stare directly into the light emitted from the LED. If a specular object is used, take care not to allow reflected light to enter your eyes.



Do not touch the terminals while the power supply is ON. Doing so may result in electrical shock.



Please take external safety measures so that the system as a whole should be on the safe side even if a failure of a Sensor Controller, a failure of a 3D Vision Sensor, or an error due to an external factor occurred. An abnormal operation may result in serious accident.



Please take fail-safe measures on your side in preparation for an abnormal signal due to signal conductor disconnection and/or momentary power interruption. An abnormal operation may result in a serious accident.



FH series must be handled by those who have the expertise in electricity. Read the reference manuals carefully to understand the contents well and make the proper use of this product accordingly. Keep this document safely for ready reference at any time. Note that this document does not include detailed information on the use of this product, including safety precautions. Please obtain manuals and instructions of the devices and equipment that constitute the system, and thoroughly read precautions such as "Safety Precautions", "Precautions for Safe Use", and "Precautions for Correct Use" before using the system.



According to Article 36, 31 and 32 of the Occupational Health and Safety Regulations, work to teach, inspect, repair and adjust industrial robots falls under "dangerous or harmful work" as defined in the Occupational Health and Safety Act. Under Article 59 of the Occupational Safety and Health Act, operators are obliged to provide workers with "special training for safety or health".



Check the measurement results before operating the robot. Otherwise the robot may act in an unintended manner. Change the workpiece position and angle of picking/placing and check the operation thoroughly.



The scene variables and system variables that are set in advance for the scene loaded with the environment copy function are automatically set using operations on the dialog box. Do not directly set them using the processing item setting screen or the TDM editor.



FH series does not comply with the laws and regulations for industrial robot safety. When using the FH series in a robot system that includes an industrial robot, be sure to check for compliance with laws and regulations regarding the safety of industrial robots. Take steps to ensure safety as needed.



It is your responsibility to implement appropriate safety measures based on the results of risk assessment. Compliance with the Robot Safety Guide and all of the information contained in our Robotic System Product Information does not guarantee that personal injury or damage to equipment caused by an industrial robot will be avoided.



During maintenance, disconnect the robot's AC power supply and lock out or tag out the power supply to prevent powering up. If the following safety measures are not taken, the subject robot may cause death or serious injury or damage to the robot itself or its peripheral equipment.



- Workers who install, operate, teach, program, or maintain the system should read the "Robot Connection Guide (Cat. No. Z448, Z447)" and "Robot Safety Guide (Cat. No. I590)" and take a training course on their responsibilities with the robot.
- Those who design a robot system must read this document and the Robot Safety Guide and follow the safety regulations and laws in the area where the robot will be installed.
- Do not use the subject robot for any purpose other than those described in this document and the manuals referred to in the Robot Connection Guide. If you are not sure whether your application is compatible, please contact us.
- The user is responsible for installing safety barriers around the robot to prevent workers from entering the work area and coming into contact with it while it is in operation.
- During maintenance, the power to the robot and the main power supply must be locked out and tagged out (measures and indication of prohibition from being turned on) to prevent them from being turned on.

If you proceed to the next step before registering the HandEye calibration start position, the robot may operate unintentionally. Be sure to register the start position.



The robot is driven by pressing the Jog Move button and the Robot Move button. The operation must be done by shoes who have completed special health and safety training. The system must be operated so that it can be stopped at any time by an emergency stop button.



Check the measurement results before operating the robot. Otherwise the robot may act in an unintended manner. Change the workpiece position and angle and check the operation thoroughly.



If the robot is operated with an incorrectly shaped hand, the robot may pick and hold the workpiece in an unintended position and/or posture, damaging the workpiece, container, or hand and causing it to fly out into the environment. Check the dimensions of the drawing and the actual product and make registration securely. Change the workpiece position and angle of picking/placing and check the operation thoroughly. The system must be operated so that it can be stopped at any time by an emergency stop button.



If the robot is operated with an incorrectly selected picking and holding DB or hand data, the robot may pick and hold the workpiece in an unintended position and/or posture, damaging the workpiece, container, or hand and causing it to fly out into the environment. Select the proper picking and holding DB in the picking and holding plan setting. Make sure to perform offline measurement before operating the robot to confirm that the proper hand is selected.













If the robot is operated with incorrect environment data, it may act in an unintended manner, resulting in contact with humans, scattering of workpieces, and contact with surrounding objects. Make sure that the proper environment file for the robot is loaded.



If the robot is operated after changing the floor or container height, it may collide with the floor. If the container position or floor level is changed, register the floor level and container again.





<p>If the 3D Vision Sensor shape is not registered, the 3D Vision Sensor may collide with the container and be damaged. Please register the 3D Vision Sensor shape when you register the hand data.</p>	
<p>Do not perform camera calibration during the warm-up operation of the 3D Vision Sensor.</p>	
<p>Measurement errors occur when the geometric positional relationship between the lighting section and imaging section of the 3D Vision Sensor changes due to factors such as aging, temperature changes, or impact on the 3D Vision Sensor. Perform a camera calibration check on a regular basis and calibrate the camera if necessary.</p>	
<p>Do not perform hand-eye calibration during the warm-up operation of the 3D Vision Sensor.</p>	
<p>Complete sensor calibration before performing hand-eye calibration.</p>	
<p><b>Anti-virus protection</b> Install the latest commercial-quality antivirus software on the computer connected to the control system and maintain to keep the software up-to-date.</p>	
<p><b>Security measures to prevent unauthorized access</b> Take the following measures to prevent unauthorized access to our products.</p> <ul style="list-style-type: none"> <li>• Install physical controls so that only authorized personnel can access control systems and equipment.</li> <li>• Reduce connections to control systems and equipment via networks to prevent access from untrusted devices.</li> <li>• Set strong passwords and change them frequently.</li> <li>• Scan virus to ensure safety of USB drives or other external storages before connecting them to control systems and equipment.</li> </ul>	
<p><b>Data input and output protection</b> Validate backups and ranges to cope with unintentional modification of input/output data to control systems and equipment.</p> <ul style="list-style-type: none"> <li>• Checking the scope of data</li> <li>• Checking validity of backups and preparing data for restore in case of falsification and abnormalities</li> <li>• Safety design, such as emergency shutdown and fail-soft operation in case of data tampering and abnormalities</li> </ul>	
<p><b>Data recovery</b> Backup data and keep the data up-to-date periodically to prepare for data loss.</p>	
<p>When using an intranet environment through a global address, connecting to an unauthorized terminal such as a SCADA, HMI or to an unauthorized server may result in network security issues such as spoofing and tampering. You must take sufficient measures such as restricting access to the terminal, using a terminal equipped with a secure function, and locking the installation area by yourself.</p>	
<p>When constructing an intranet, communication failure may occur due to cable disconnection or the influence of unauthorized network equipment. Take adequate measures, such as restricting physical access to network devices, by means such as locking the installation area.</p>	

When using a device equipped with the USB flash drive or SD Memory Card function, there is a security risk that a third party may acquire, alter, or replace the files and data in the removable media by removing the removable media or unmounting the removable media. Please take sufficient measures, such as restricting physical access to the Controller or taking appropriate management measures for removable media, by means of locking the installation area, entrance management, etc., by yourself.



 **Caution**

Danger of burns. Do not touch the case while the power is ON or just after power is turned OFF, since it remains extremely hot.



If the camera calibration is performed with the target tilted, the measurement error may deteriorate. Ensure that the calibration target is placed in a stable position on a flat floor.



If the camera calibration is performed while the target is dirty, the measurement error may deteriorate. If the camera calibration target is dirty, wring out a wet towel, wipe it clean, and dry it with a soft cloth before performing the calibration.



If the camera calibration is performed while the 3D Vision Sensor is dirty, the measurement error may deteriorate. If the 3D Vision Sensor window surface is dirty, wring out a wet towel, wipe the dirt off, and dry with a dry cloth.



When operating the jog, check the actual robot visually instead of the camera image.



The robot is driven when using the motion sample program. The operation must be done by shoes who have completed special health and safety training. The system must be operated so that it can be stopped at any time by an emergency stop button.



If the operation range of hand-eye calibration is not set correctly, the robot may act in an unexpected position and/or posture that may result in contact with surrounding objects. Make sure that the calibration trajectory is clear and that there are no obstacles or people in the vicinity. The system must be operated so that it can be stopped at any time by an emergency stop button.



When placing the camera calibration target, place it slowly so that your hands do not get caught on the floor.



# Precautions for Safe Use

Be sure to respect following items for safety.

## Condition of the Fitness of OMRON Products

- *Omron products* are designed and manufactured as general-purpose products for use in general industrial applications. They are not intended to be used in the following critical applications. If you are using *Omron products* in the following applications, *Omron* shall not provide any warranty for such *Omron products*, unless otherwise specifically agreed or unless the specific applications are intended by Omron.
  - a) Applications with stringent safety requirements, including but not limited to nuclear power control equipment, combustion equipment, aerospace equipment, railway equipment, elevator/lift equipment, amusement park equipment, medical equipment, safety devices and other applications that could cause danger/harm to people's body and life.
  - b) Applications that require high reliability, including but not limited to supply systems for gas, water and electricity, etc., 24 hour continuous operating systems, financial settlement systems and other applications that handle rights and property.
  - c) Applications under severe condition or in severe environment, including but not limited to outdoor equipment, equipment exposed to chemical contamination, equipment exposed to electromagnetic interference and equipment exposed to vibration and shocks.
  - d) Applications under conditions and environment not described in specifications.
- 1. In addition to the applications listed from (a) to (d) above, *Omron products* (see definition) are not intended for use in vehicles designed human transport (including two wheel vehicles). Please do NOT use Omron products for vehicles designed human transport. Please contact the Omron sales staff for information on our automotive line of products.
- 2. The above is part of the Terms and Conditions Agreement. Please use carefully read the contents of the guarantee and disclaimers described in our latest version of the catalog, data sheets and manuals.

## Installation Environment (FH-5050)

- Do not use the product in the environment with flammable or explosive gases.
- Install the product so that the air can flow freely through its cooling vents.
- Regularly clean the vent holes or fan outlet to prevent dust or particles blocking them. Internal temperature increases when those are blocked, it causes malfunction.
- To secure safety for operation and maintenance, install the product apart from high-voltage devices and power devices.
- Make sure to tighten all screws in mounting.
- When mounting the product, be sure to tighten all screws.

## Power Supply and Wiring (FH-5050)

- Make sure to use the product within the power voltage specified by catalog, this manual, or instruction sheet.
- Never connect the product to AC power. If connected, it causes malfunction.

- Select and use the appropriate wire size based on consumption current.
- Keep the power supply wires as short as possible.
- Provide the power from a DC power supply (safety extra-low voltage circuits) that has been taken measures not to generate high-voltage.
- Check the following again before turning on the power.
  - Is the voltage and polarity of the power supply correct? (24 VDC)
  - Is not the load of the output signal short-circuited?
  - Is the load current of the output signal appropriate?
  - Is not the mistake found in wiring?
  - Is the voltage and polarity of the encoder power (ENC0\_VDD/GND ENC1\_VDD/GND) supply? (5VDC)

### Grounding (FH-5050)

- Since the power supply circuit for the Sensor Controller is described in the manual and instruction sheet, please check it.
- When a base is packed in a camera that will be connected to the Sensor Controller, make sure to mount the camera using the base. Since the enclosure of the camera body is connected to the internal circuits, the circuits may cause short-circuit with FG if the base is not used to mount the camera and result in malfunction or damage.
- Apply Class D grounding (grounding resistance: 100 [ $\Omega$ ] or less) Wire the grounding wire for the Sensor Controller independently. If the grounding wire is shared with other devices or connected to a building beam, the Sensor Controller may be adversely affected.
- Do not ground the plus (+) terminal when the Sensor Controller is connected to the FH-SC12/FH-SM12. The internal circuits may cause a short-circuit and result in malfunction.
- When using the Sensor Controller and the peripheral devices such as a monitor, USB connection devices, RS-232C connection devices, there should be no potential difference in ground level. If not, it may cause malfunction.  
Take measures that the potential difference does not occur between the grounds for the Sensor Controller and the peripheral devices.

### Others (FH-5050)

- Use only the camera and cables designed specifically for the product. Use of other products may result in malfunction or damage of the product.
- Always turn OFF the power of the Sensor Controller and peripheral devices before connecting or disconnecting a camera or cable. Connecting the cable with power supplied may result in damage of the camera or peripheral devices.
- For the cable that is flexed repeatedly, use the robotic cable type (Bend resistant camera cable) to prevent damages.
- Do not apply torsion stress to the cable. It may damage the cable.
- Secure the minimum bending radius of the cable. Otherwise the cable may be damaged.
- Do not apply stress to the connector by pulling or bending the cable. It may damage the connector.
- Do not attempt to dismantle, repair, or modify the product.
- Should you notice any abnormalities, immediately stop use, turn OFF the power supply, and contact your OMRON representative.

- Do not drop the product nor apply excessive vibration or shock to the product. Doing so may cause malfunction or burning.
- This product is heavy. Be careful not to drop it while handling.
- Be sure to take fail-safe measures externally when controlling stages and robots by using the measurement results of the Sensor Controller (axis movement output by calibration and alignment measurement).

## Installation Environment (FH-SMDA-GS050B)

- Do not use the product in the environment with flammable or explosive gases.
- To secure safety for operation and maintenance, install the product apart from high-voltage devices and power devices.
- Avoid installing the product in places with vibration as much as possible.

## Power Supply and Wiring (FH-SMDA-GS050B)

- Make sure to use the product with the power supply voltage specified. If a DC voltage exceeding the rating or an AC voltage is applied, the circuit parts may be burnt or exploded.
- Do not connect the power supply with polarity reversed.
- Use a DC power supply with safety measures against high-voltage spikes (safety extra low-voltage circuits on the secondary side).
- Use an independent power source for this product. Do not use a shared power source.
- Never apply more than the rated voltage or AC power supply to this product. It may cause malfunction.
- The recommended power supplies are as follows:
  - When not attaching the lighting module, use S8VK-G06024 (OMRON) or S8VS-06024 (OMRON).
- Wire high-voltage cables or power cables are separated from the cables of this product. If the same cable or duct is used, the product may receive induction and it may cause malfunctioning or breakage.
- Do not short-circuit the load on the open collector output.
- Apply load not exceeding the rating.
- Before wiring an I/O cable, attach a crimping terminal. Do not connect cables just twisted together to the power supply or terminal block directly.
- Insulate unnecessary signal cables so that they do not contact any other signal cables.
- After wiring the cables, confirm if the power supply is appropriate, if there is miswiring such as short-circuit of load, if the load current is appropriate, and if FG is connected appropriately. Otherwise, the product may be broken due to miswiring etc.
- Take enough safety measures such as a failsafe circuit before using the product.
- Be sure to apply Class D grounding (100Ω or lower grounding resistance) to the ground wire of the I/O cable.
- Do not share the ground wire with some other devices or connect it to the beam of the building. The product may be adversely affected.
- Determine the contact point as near as possible to shorten the ground wire as much as possible. The product may be adversely affected.
- For positive ground, please refer to cautions described in the setup manual.
- Do not touch the optical surface of the camera or the lighting section during wiring or installation. It may affect the characteristics.

### Mounting (FH-SMDA-GS050B)

- When doing the following, be sure to turn OFF the power of the 3D vision sensor or connected peripheral devices. Not doing so leads to a product failure.
  - Cable connection and wiring
  - Connector mounting/removal
- Tighten the mounting screws securely using the defined torque. (Screw: M4 x 4, Tightening torque: 1.2 N•m)
- Do not apply torsional stress to the cable. Doing so may cause cable breakage.
- Secure the minimum bending radius of the cable. If it cannot be secured, the cable may be broken.

### Others (FH-SMDA-GS050B)

- Use only the dedicated cable (FHV-VNBX / FHV-VNLBX and FHV-VSDX-BX / FHV-VSDX-LBX). Otherwise, the product may malfunction or be broken.
- If anything abnormal occurs, for example, strange smell/sound is detected, the main unit gets very hot, or a smoke comes, stop using the product, turn OFF the product, and consult OMRON's branch or sales office.
- Do not disassemble, deform by pressurizing, incinerate, repair, or alter this product.
- When disposing of the product, treat as industrial waste.
- Do not use the product for atomic power or safety circuits endangering human lives.
- Do not drop the product or expose it to abnormal vibration or impact. Doing so may lead to product failure.
- When operating the robot by using the vision sensor measurement results, be sure to check the measurement result data on the robot side and take fail-safe measures, such as operating the robot only after confirming that the data is within the robot's range of motion.
- 3D Vision Sensor measurements are relative, not absolute. It cannot be used as a measurement sensor.

### Camera Calibration Target (FH-XCAL-S)

- Install and store the product in a location that meets the following conditions:
  - Ambient temperature and relative humidity do not exceed the range of specifications
  - No rapid changes in temperature (place where dew does not form)
  - No presence of corrosive or flammable gases
  - Place free of dust, salts and iron particles
  - Place free of vibration and shock
  - Place out of direct sunlight
  - Place where it will not come into contact with oils or chemicals
- Do not drop the product nor apply excessive vibration or shock to the product. Doing so may cause malfunction or burning.
- Place the camera calibration target in a stable position on a flat floor.
- Set the camera calibration target within the measurement distance and measurement range of the 3D Vision Sensor to calibrate the camera.
- Before performing camera calibration automatically, make sure that the robot is in a coordinate position that does not collide with the target.

## HandEye Calibration Target (FH-XCAL-R)

- Install and store the product in a location that meets the following conditions:
  - No rapid changes in temperature (place where dew does not form)
  - No presence of corrosive or flammable gases
  - Place free of dust, salts and iron particles
  - Place free of vibration and shock
  - Place out of direct sunlight
  - Place where it will not come into contact with oils or chemicals
- Do not drop the product nor apply excessive vibration or shock to the product. Doing so may cause malfunction or burning.
- Set the hand-eye calibration target within the measurement distance and measurement range of the 3D Vision Sensor to performing hand-eye calibration.
- When performing hand-eye calibration, make sure that there is no workpiece around the hand-eye calibration target.
- Install the hand-eye calibration target on a flat floor in a stable condition without vibration.
- If the hand-eye calibration target is dirty, wring out a wet towel, wipe off the dirt, and dry with a soft cloth.
- If the 3D Vision Sensor window surface is dirty, wring out a wet towel, wipe the dirt off, and dry with a dry cloth.
- Check that the hand-eye calibration result shows an error of approximately 1 or less.

# Precautions for Correct Use

Please observe the following precautions to prevent failure to operate, malfunction, or undesirable effect.

## Installation and Storage Sites (FH-5050)

Install and store the product in a location that meets the following conditions:

- Surrounding temperature of 0 to +45°C (-20 to +65°C in storage)
- No rapid changes in temperature (place where dew does not form)
- Relative humidity of between 35 to 85%
- No presence of corrosive or flammable gases
- Place free of dust, salts and iron particles
- Place free of vibration and shock
- Place out of direct sunlight
- Place where it will not come into contact with water, oils or chemicals
- Place not affected by strong electro-magnetic waves
- Place not near to high-voltage, or high-power equipment

## Orientation of Product (FH-5050)

- For efficient heat dissipation, install the product only with the orientation written in this manual or the Instruction Sheet. Install the product so that the air can flow freely through its cooling vents.

## Ambient Temperature (FH-5050)

- To secure good ventilation, install the product with clearance written in this manual or the Instruction Sheet.
- Do not install the product immediately above significant heat sources, such as heaters, transformers, or large-capacity resistors.
- Use the product within the operating temperature range based on the specifications of it.
- Install a forced cooling fan or air conditioner not to exceed the operating temperature range when the ambient temperature is close to the upper limit of its range.

## Component Installation and Handling (FH-5050)

- When touching a terminal part or a signal wire in a connector, take anti-static measures using a wrist strap or another device to prevent damage from static electricity.
- Handling a USB flash drive/ SD memory card: (Refer to *Using External Storage Device* in the *Vision System FH/FHV Series User's Manual (Cat. No. Z365)*.

Do not insert an SD memory card in the reverse orientation, at an angle, or in a twisting manner.

Before removing a USB flash drive, make sure that data is not being read or written to them.

Before removing a SD memory card, make sure that data is not being read or written to them.

For a USB flash drive, the memory device's LED flashes or lights while data is being read or written, so make sure that it is turned OFF before removing the memory.



For SD memory card, the SD BUSY LED flashes or lights while data is being read or written, so make sure that it is turned OFF before removing the memory.

- Turning OFF the Power:

When a message is displayed indicating that a task is in progress, do not turn OFF the power. Doing so causes the data in the memory to be corrupted, resulting in the product not operating properly upon the next start-up.

Do not turn OFF during saving data to Sensor Controller.

When turns OFF, conform the followings proceedings have completed. and then operate again.

- When saves using Sensor Controller: Confirm the save processing is completed and next operation is possible.
- When saves using communication command: Intended command is completed. BUSY signal is turned OFF.
- After turning off the power, wait at least 1 second before restarting.

## Maintenance (FH-5050)

- Turn OFF the power and ensure the safety before maintenance.
- Clean the lens with a lens-cleaning cloth or air brush.
- Lightly wipe off dirt with a soft cloth.
- Dirt on the image element must be removed using an air brush.
- Do not use thinners or benzine.
- To secure safety for operation and maintenance, install the product apart from high-voltage devices and power devices.

## Communications with Upper Device (FH-5050)

- After confirming that the product is started up, communicate with the high-order device. During start-up, an indefinite signal may be output to the high-order interface. To avoid this problem, clear the receiving buffer of your device at initial operations.

## Failsafe Measures (FH-5050)

- Be sure to take fail-safe measures externally when controlling stages and robots by using the measurement results of the Sensor Controller (axis movement output by calibration and alignment measurement).
- On a Sensor Controller side, supplementary use operations and branches of the Sensor Controller to configure a check flow such as “data should not be externally provide if the data is in a range from -XXXXX to XXXXX” based on the stage/robots range of movement.

## Connecting the Sensor Controller and Monitor with a Switcher and Splitter

- Do not use devices that may require re-recognition of the monitor by the Sensor Controller when a switching operation was performed. If such re-recognition processing happens at switching operation, it may cause measurement time to be longer.

## Installation Location (FH-SMDA-GS050B)

In order to prevent the product from becoming inoperable or malfunction, and to prevent other adverse effects to the performance or equipment, please observe the following.

- A location where the ambient temperature does not exceed the rated range.
- A location where the temperature does not vary sharply (condensation occurs).
- A location where relative temperature does not exceed a range of 35-85%.
- A location not exposed to corrosive gases or combustible gases.
- A location not exposed to dust, salt, or metal powder.
- A location not exposed to direct vibration or impact.
- A location not exposed to strong disturbance light (laser light, arc welding light, or ultraviolet light).
- A location not near a heating appliance or exposed to direct sunlight.
- A location not exposed to mist of water, oil, or chemicals or misty atmosphere.
- A location not exposed to strong magnetic/electric fields.
- A location not near a high-voltage device or power device

## Power Supply, Connection, and Wiring (FH-SMDA-GS050B)

- If using a commercially available switching regulator, earth the frame ground terminal.
- If the power supply line has surge, connect a surge absorber according to the operational environment to use the product.
- After wiring the cables, confirm if the power supply is appropriate, if there is miswiring such as short-circuit of load, or if the load current is appropriate. Otherwise, the product may be broken due to miswiring etc.
- Do not put load on the cables and connectors before wiring them.
- Turn on the power of the 3D Vision Sensor at the same time as or before turning on the power of the FH sensor controller.
- When turning OFF the power, confirm that data have been saved completely before starting operations.
  - When data are saved by operating the 3D vision sensor, the saving process must have been completed and the following user operations must be possible.
  - When data are saved using communication commands, processing of the applicable commands must have been completed and the busy state is OFF.
- Attach the cable straight with the terminal correctly aligned. Forcibly attaching the cable may bend the terminal, resulting in failure or communication error.
- Insulate the unused signal lines of the I/O cable so that the signal lines do not come into contact with other signal lines.

## Maintenance (FH-SMDA-GS050B)

- Turn OFF the power and confirm safety before starting maintenance.
- Remove dirt on the window using the special cloth for lens or an air brush.
- Do not use thinner, alcohol, benzene, acetone, or kerosene to clean his product.

## Optical axis (FH-SMDA-GS050B)

- The field of view may vary product by product. When mounting this product, be sure to confirm video using the sensor controller.

## Image Sensor (FH-SMDA-GS050B)

- For this product, a line may appear depending on the measurement condition or sensitivity because of the specification of the image sensor.  
However, this is not a fault or failure of the product. In addition, although there may be multiple defective pixels, this is not a fault or failure of the product. Use the product as confirming the actual image.

## Failsafe Measures (FH-SMDA-GS050B)

- When operating the robot by using the vision sensor measurement results, be sure to check the measurement result data on the robot side and take fail-safe measures, such as operating the robot only after confirming that the data is within the robot's range of motion.

## Warm-up (FH-SMDA-GS050B)

- The correct brightness and focus may not be achieved or may fluctuate until the product function is stabilized (approximately 15 minutes) after power-on. Check the WARM UP indicator LED or the warm-up completion flag in the camera image input processing item on the FH software before using the product.

## Camera Installation (FH-SMDA-GS050B)

- In an environment exposed to high humidity and sharp temperature fluctuation, the window may become cloudy in rare cases.

## Connection and Operation with the Robot (FH-SMDA-GS050B)

- For an example design of a robot program to build an application, see the sample program (fhsample\_main()) of the Robot Connection Guide.
- For the processing to move the robot to the imaging position, refer to the Robot Connection Guide.
- If you proceed to the next step before registering the workpiece reference position, the robot may operate unintentionally. Be sure to register the start position.
- If you proceed to the next step before registering the robot's picking and holding position, the robot may operate unintentionally. Be sure to register the start position.

## LED Safety (FH-SMDA-GS050B)

This product is classified into the following risk groups by IEC62471.

LED safety	Display
Risk group 2	<div style="border: 1px solid black; padding: 5px; text-align: center;"> <p><b>CAUTION</b></p> <p>Possibly hazardous optical radiation emitted from this product</p> <p><b>Risk Group 2 IEC 62471</b></p> </div>

### Camera Calibration Target (FH-XCAL-S)

- Do not use thinner, alcohol, benzene, acetone, or kerosene to clean his product.
- Before calibrating the camera, make a backup of the AOS camera information file.
- After calibrating the camera, check the results to confirm that the calibration was successful. When an abnormal AOS camera information file is read, the measurement error increases and the wrong coordinate position is output.
- When disposing of this product, treat it as industrial waste and never heat or incinerate it at 100 °C or higher.

### HandEye Calibration Target (FH-XCAL-R)

- Do not use thinner, alcohol, benzene, acetone, or kerosene to clean his product.
- When disposing of this product, treat it as industrial waste and never heat or incinerate it at 100 °C or higher.

# Regulations and Standards

## FH-5050

### Using Product Outside Japan

If you export (or provide a non-resident with) this product or a part of this product that falls under the category of goods (or technologies) specified by the Foreign Exchange and Foreign Trade Control Law as those which require permission or approval for export, you must obtain permission or approval (or service transaction permission) pursuant to the law.

### U.S. California Notice:

This product contains a lithium battery for which the following notice applies: Perchlorate Material - special handling may apply.

See "[www.dtsc.ca.gov/hazardouswaste/perchlorate](http://www.dtsc.ca.gov/hazardouswaste/perchlorate)".

### Conformance to KC Standards

Observe the following precaution if you use this product in Korea.

사 용 자 안 내 문

이 기기는 업무용 환경에서 사용할 목적으로 적합성평가를 받은 기기로서 가정용 환경에서 사용하는 경우 전파간섭의 우려가 있습니다.

- Guidance for users

This product meets the electromagnetic compatibility requirements for business use. There is a risk of radio interference when this product is used in home.

### WEEE Directive



Dispose of in accordance with WEEE Directive

### Conformance to EC/EU Directives and UK Legislation

The product is compliant with the standards below:

- EC Directive 2004/108/EC (Until April 19 2016) / EU Directive 2014/30/EU (After April 20 2016) / UK legislation 2016 No 1091 Electromagnetic Compatibility Regulations 2016 EN61326-1 Electromagnetic environment: Industrial electromagnetic environment (EN/IEC 61326-1 Table 2)
- Also, the following condition is applied to the immunity test of this product.

- If the level of disturbance of the video is such that characters on the monitor are readable, the test is a pass.
- EMC-related performance of the OMRON devices will vary depending on the configuration, wiring, and other conditions of the equipment or control panel on which the OMRON devices are installed.
- The customer must, therefore, perform the final check to confirm that devices and the overall machine conform to EMC standards.
- If there is a need to respond to the EC / EU directive and UK legislation, please use by an analog RGB output.

### Conformance to UL Standards

---

This product complies with UL Standards.

- UL61010-2-201

## FH-SMDA-GS050B

### Using Product Outside Japan

---

If you export (or provide a non-resident with) this product or a part of this product that falls under the category of goods (or technologies) specified by the Foreign Exchange and Foreign Trade Control Law as those which require permission or approval for export, you must obtain permission or approval (or service transaction permission) pursuant to the law.

### Conformance to KC Standards

---

Observe the following precaution if you use this product in Korea.

사 용 자 안 내 문

이 기기는 업무용 환경에서 사용할 목적으로 적합성평가를 받은 기기로서 가정용 환경에서 사용하는 경우 전파간섭의 우려가 있습니다.

- Guidance for users

This product meets the electromagnetic compatibility requirements for business use. There is a risk of radio interference when this product is used in home.

### Conformance to EU Directives

---

The product is compliant with the standards below:

- EU Directive 2014/30/EU EN61326-1 Electromagnetic environment: Industrial electromagnetic environment (EN/IEC 61326-1 Table 2)
- EMC-related performance of the OMRON devices will vary depending on the configuration, wiring, and other conditions of the equipment or control panel on which the OMRON devices are installed.
- The customer must, therefore, perform the final check to confirm that devices and the overall machine conform to EMC standards.

# Related Manuals

The followings are the manuals related to this manual. Use these manuals for reference.

Name of Manual	Cat. No.	Model	Purpose	Contents
Vision System FH Instruction Sheet	3615791-1	FH-2□□□ FH-5□□□ FH-2□□□-□□ FH-5□□□-□□	To confirm the safety and usage precautions of the Vision System FH series Sensor Controller.	Describes the definitions of basic terms, meaning of signal words, and precautions for correct use of FH series in the manual.
3D Vision Sensor FH-SMDA Instruction Sheet	3290410-0	FH-SMDA-GS050B	To confirm the safety and usage precautions of the 3D Vision Sensor FH-SMDA.	Describes the definitions of basic terms, the meaning of signal words, and precautions for correct use of 3D Vision Sensor FH-SMDA in the manual.
FH Application Software FH-UM3D1 Instruction Sheet	5665477-6	FH-UM3D1	To confirm the safety and usage precautions of the FH Application Software FH-UM3D1. When User want to know about the hardware specifications or to setup the FH Application Software FH-UM3D1.	Describes the definitions of basic terms, product specifications, how to use, meaning of signal words, and precautions for correct use of FH Application Software FH-UM3D1 in the manual.
Vision System FH series 3D Robot Vision Application Construction Guide	Z446	FH-5050 FH-SMDA-GS050B	When User want to know about the FH series 3D robot vision system.	Describes the soft functions, setup, and operations to use FH series 3D robot vision system.
Vision System FH series Hardware Setup Manual for 3D Robot Vision	Z436		When User want to know about the Hardware specifications or to setup the Sensor Controller of the FH series 3D robot vision system.	Describes FH series 3D robot vision system specifications, dimensions, part names, I/O information, installation information, and wiring information.
Vision System FH series Processing Item Function Reference Manual for 3D Robot Vision	Z445		When User confirm the details of each processing items at the create the measurement flow or operate it.	Describes the software functions, settings, and operations for using FH series 3D robot vision system.

Name of Manual	Cat. No..	Model	Purpose	Contents
Vision System FH/FHV Series User's Manual	Z365	FH-2□□□ FH-2□□□-□□ FH-5□□□	When User want to know about the FH/FHV series.	Describes the soft functions, setup, and operations to use FH/FHV series.
Vision System FH/FHV series Processing Item Function Reference Manual	Z341	FH-5□□□-□□ FH-L□□□ FH-L□□□-□□ FHV7□-□□□□□-□□□	When User confirm the details of each processing items at the create the measurement flow or operate it.	Describes the software functions, settings, and operations for using FH/FHV series.
Vision System FH/FHV Series User's manual for Commu- nications Settings	Z342		When User confirm the setting of communication functions.	Describes the functions, settings, and communications methods for communication between FH/FHV series and PLCs. The following communications protocol are described. Parallel, PLC Link, EtherNet/IP, EtherCAT, and Non-procedure.
Vision System FH series Macro Customize Func- tions Programming Manual	Z367	FH-2□□□ FH-2□□□-□□ FH-5□□□ FH-5□□□-□□ FH-L□□□ FH-L□□□-□□	When User operate or programming using Macro Customize functions.	Describes the functions, settings, and operations for using Macro Customize function of the FH series.



# Revision History

A manual revision code appears as a suffix to the catalog number on the front and back covers of the manual.

<b>Cat. No.</b>	<b>Z436-E1-03</b>
-----------------	-------------------

↑  
Revision code

Rev. Code	Rev. Date	Revision Contents
01	Feb. 2021	Original product
02	Sep. 2022	Revisions for adding safety precautions regarding security Removed FAE-5002 and FAE-5004 Removed HMC-SD491 and HMC-SD291 Added HMC-SD492 and HMC-SD292 Touch panel monitor specification change
03	Dec. 2022	Revisions for update <i>Precautions for Safe Use, Precautions for Correct Use, Regulations and Standards, Related Manuals.</i> Added models for camera cables.



# 1

## Confirm the Package

---

<b>1-1</b>	<b>Sensor Controller .....</b>	<b>1-2</b>
1-1-1	FH-5050 .....	1-2
<b>1-2</b>	<b>3D Cameras and Related .....</b>	<b>1-3</b>
1-2-1	Camera .....	1-3
1-2-2	Camera Cable .....	1-3
1-2-3	Camera I/O Cable .....	1-3
<b>1-3</b>	<b>FH Application Software .....</b>	<b>1-4</b>
<b>1-4</b>	<b>Calibration Target .....</b>	<b>1-5</b>
<b>1-5</b>	<b>Sold Separately .....</b>	<b>1-6</b>
1-5-1	Monitor .....	1-6
1-5-2	Lighting and Lighting Controller .....	1-7
1-5-3	Accessories .....	1-7
1-5-4	Cable .....	1-8

# 1-1 Sensor Controller

---

First, please check to see whether the package has all the necessary Sensor Controller parts.

## 1-1-1 FH-5050

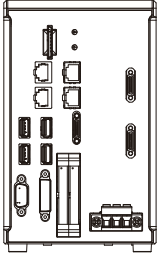





- Sensor Controller: 1  
FH-5050: 1
- Instruction sheet: 1
- Instruction Installation Manual for FH series: 1
- General Compliance Information and Instructions for EU: 1
- Membership registration: 1
- Power source: 1 (male)  
FH-XCN: 1
- Ferrite core for camera cable: 2

## 1-2 3D Cameras and Related

### 1-2-1 Camera

Appearance	Type	Field of vision	Imaging area	Model
	3D vision sensor	400 x 300 mm	400 to 600 mm	FH-SMDA-GS050B

### 1-2-2 Camera Cable



Appearance	Description	Model
	Ethernet cable super bending resistance straight Cable length: 5 m, 10 m	FHV-VNBX2 □M*1
	Ethernet cable super bending resistance right-angle *3 Cable length: 5 m, 10 m	FHV-VNLBX2 □M*1
	Ethernet cable super bending resistance straight Cable length: 3 m, 5 m, 10 m	FHV-VNBX □M*2
	Ethernet cable super bending resistance right-angle *3 Cable length: 3 m, 5 m, 10 m	FHV-VNLBX □M*2

\*1. Insert the cables length into □ in the model number as follows. 5 m = 5, 10 m = 10

\*2. Insert the cables length into □ in the model number as follows. 3 m = 3, 5 m = 5, 10 m = 10

\*3. This Cable has an L-shaped connector on the Camera end.

### 1-2-3 Camera I/O Cable

Appearance	Description	Model
	I/O cable super bending resistance straight Cable length: 3 m, 5 m, 10 m	FH-VSDX-BX □M*1
	I/O cable super bending resistance right-angle *2 Cable length: 3 m, 5 m, 10 m	FH-VSDX-LBX □M*1

\*1. Insert the cables length into □ in the model number as follows. 3 m = 3, 5 m = 5, 10 m = 10

\*2. This Cable has an L-shaped connector on the Camera end.

## 1-3 FH Application Software

Appearance	Description	Model
	3D Robot Vision Software Installer *1	FH-UM3D1

\*1. This product can be installed on the FH-5050 (version 6.40 or later).

## 1-4 Calibration Target

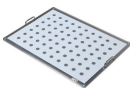

Appearance	Description	Model
	Handeye Calibration Target	FH-XCAL-R
	Camera Calibration Target	FH-XCAL-S

# 1-5 Sold Separately

## 1-5-1 Monitor

### Touch Panel Monitor and Cables



Appearance	Description	Model
	Touch Panel Monitor 12.1 inches (for FH Sensor Controllers)	FH-MT12

Appearance	Description	Model
	DVI-Analog Conversion Cable for Touch Panel Monitor Cable length: 2 m, 5 m or 10 m	FH-VMDA □M *1
	RS-232C Cable for Touch Panel Monitor Cable length: 2 m, 5 m or 10 m	XW2Z-□□ □PP-1 *2
	USB Cable for Touch Panel Monitor Cable length: 2 m or 5 m	FH-VUAB □M *1

\*1. Insert the cables length into □ in the model number as follows. 2 m = 2, 5 m = 5, 10 m = 10

\*2. Insert the cables length into □□□ in the model number as follows. 2 m = 200, 5 m = 500, 10 m = 010.

### LCD Monitor and Cable

Appearance	Description	Model
	LCD Monitor 8.4 inches for Box-type Controllers *1	FZ-M08
	LCD Monitor Cable When you connect an LCD Monitor FZ-M08 to FH sensor controller, please use it in combination with a DVI-I -RGB Conversion Connector FH-VMRGB.	FZ-VM 2M FZ-VM 5M
	DVI-I -RGB Conversion Connector	FH-VMRGB

\*1. It can be used in FH series.







## 1-5-2 Lighting and Lighting Controller

Appearance	Description			Model
-	External Lighting		-	FLV Series
-	External Lighting		-	FL Series
	Lighting Controller (Required to control external lighting from a Controller)	For FLV-Series	Analog Lighting Controller	FLV-ATC Series

For the method of setting the lighting controller, please refer to the respective instruction manual.



## 1-5-3 Accessories

Appearance	Description				Model		
	USB flash drive		2 GB		FZ-MEM2G		
			8 GB		FZ-MEM8G		
			16 GB		FZ-MEM16G		
	SD card		-		2 GB	HMC-SD292*1	
					4 GB	HMC-SD492*1	
			Inquiry of purchase: Sales Agencies <a href="http://www.hagisol.com/dealer/">www.hagisol.com/dealer/</a> Inquiry of specification: HAGIWARA Solutions Co., Ltd. <a href="http://www.hagisol.com/support/">www.hagisol.com/support/</a>		2 GB		NSD6-002GS(P1 1SEI)
					4 GB		NSD6-004GS(P1 1SEI)
	USB/Monitor Switcher				FZ-DU		
-	Mouse - Driverless wired mouse (A mouse that requires the mouse driver to be installed is not supported.)				-		
	EtherCAT junction slaves		3 ports	Power supply voltage: 20.4 VDC to 28.8 VDC (24 VDC -15 % to +20 %)	Current consumption: 0.22 A	GX-JC03	
			6 ports			GX-JC06	
	Industrial Switching Hubs for EtherNet/IP and Ethernet		3 ports	Failure detection: None	Current consumption: 0.22 A	W4S1-03B	
			5 ports	Failure detection: None		W4S1-05B	
				Failure detection: Supported		W4S1-05C	

\*1. Not use on FH-L55□/□/□-10.

## 1-5-4 Cable

### Parallel I/O Cables

Appearance	Description	Model
	Parallel I/O Cable *1 Cable length: 2 m, 5 m or 15 m	XW2Z-S013-□ *2
	Parallel I/O Cable for Connector-terminal Conversion Unit *1 Cable length: 0.5 m, 1 m, 1.5 m, 2 m, 3 m, 5 m	XW2Z-□□□EE *3
	Connector-Terminal Block Conversion Units, General-purpose devices	XW2R-□34GD-T *4

\*1. 2 Cables are required for all I/O signals.

\*2. Insert the cables length into □ in the model number as follows. 2 m = 2, 5 m = 5, 15 m = 15

\*3. Insert the cables length into □□□ in the model number as follows. 0.5 m = 050, 1 m = 100, 1.5 m = 150, 2 m = 200, 3 m = 300, 5 m = 500



\*4. Insert the wiring method into □ in the model number as follows. Phillips screw = J, Slotted screw (rise up) = E, Push-in spring = P



Refer to the *XW2R Series catalog (Cat. No. G077)* for details.

### Recommended EtherCAT and EtherNet/IP Communications Cables

Use Straight STP (shielded twisted-pair) cable of category 5 or higher with double shielding (braiding and aluminum foil tape) for EtherCAT.

Use Straight or cross STP (shielded twisted-pair) cable of category 5 or higher for EtherNet/IP.

Appearance	Description	Model
	For Ether-CAT Cable with Standard type Connectors on Both Ends (RJ45/RJ45) <ul style="list-style-type: none"> <li>Wire Gauge and Number of Pairs: AWG27, 4-pair Cable</li> <li>Cable Sheath material: LSZH *1</li> <li>Cable color: Blue, Yellow, or Green</li> <li>Cables length: 0.2 m, 0.3 m, 0.5 m, 1 m, 1.5 m, 2 m, 3 m, 5 m, 7.5 m, 10 m, 15 m, 20 m</li> </ul>	XS6W-6LSZH8S S□CM-Y
	Cable with Rugged type Connectors on Both Ends (RJ45/RJ45) <ul style="list-style-type: none"> <li>Wire Gauge and Number of Pairs: AWG22, 2-pair Cable</li> <li>Cables length: 0.3 m, 0.5 m, 1 m, 2 m, 3 m, 5 m, 10 m, 15 m</li> </ul>	XS5W-T421- □MD-K
	Cable with Rugged type Connectors on Both Ends (M12/RJ45) <ul style="list-style-type: none"> <li>Wire Gauge and Number of Pairs: AWG22, 2-pair Cable</li> <li>Cables length: 0.3 m, 0.5 m, 1 m, 2 m, 3 m, 5 m, 10 m, 15 m</li> </ul>	XS5W-T421- □MC-K

Appearance	Description				Model
		Cable with Rugged type Connectors on Both Ends (M12 L/RJ45)			XS5W-T422- □MC-K
		<ul style="list-style-type: none"> <li>Wire Gauge and Number of Pairs: AWG22, 2-pair Cable</li> <li>Cables length: 0.3 m, 0.5 m, 1 m, 2 m, 3 m, 5 m, 10 m, 15 m</li> </ul>			
-	For Ether-CAT and EtherNet/IP	Wire Gauge and Number of Pairs: AWG24, 4-pair Cable	Cables	Hitachi Metals, Ltd.	NETSTAR-C5E SAB 0.5 x 4P CP *2
-				Kuramo Electric Co.	KETH-SB *2
-				JMACS Japan Co.,Ltd.	IETP-SB *2
-		RJ45 Connectors	Panduit Corporation	MPS588-C *2	
-		Wire Gauge and Number of Pairs: AWG22, 2-pair Cable	Cables	Kuramo Electric Co.	KETH-PSB-OMR *3
-				JMACS Japan Co.,Ltd.	PNET/B *3
		RJ45 Assembly Connector	OMRON	XS6G-T421-1	
-	For Ether-Net/IP	Wire Gauge and Number of Pairs: 0.5mm x 4P	Cables	Fujikura Ltd.	F-LINK-E 0.5mm x 4P *4
-			RJ45 Connectors	Panduit Corporation	MPS588 *4

- \*1. The lineup features Low Smoke Zero Halogen cables for in-cabinet use and PUR cables for out-of-cabinet use.
- \*2. We recommend you to use above cable for EtherCAT and EtherNet/IP, and RJ45 Connector together.
- \*3. We recommend you to use above cable for EtherCAT and EtherNet/IP, and RJ45 Assembly Connector together.
- \*4. We recommend you to use above cable for EtherNet/IP and RJ45 Connectors together.



### Precautions for Correct Use

Please be careful while cable processing, for EtherCAT, connectors on both ends should be shield connected and for EtherNet/IP, connectors on only one end should be shield connected.



# 2

## Overview of FH series

---

<b>2-1</b>	<b>Basic System of Measurement .....</b>	<b>2-2</b>
2-1-1	System Configuration .....	2-4
<b>2-2</b>	<b>Flow of Use Procedure .....</b>	<b>2-5</b>

## 2-1 Basic System of Measurement

---

An FH series Sensor Controller uses pre-built packages that contain all the processing tasks (for image input, measurement processing, displays, outputs, etc.) that are required for vision inspections.

You arrange these packaged processes in order of execution of the vision inspection.

An FH series Sensor Controller executes vision inspections according to user-created flows.



### **Additional Information**

---

In the FH series Sensor Controller, a flow that contains packaged processes that are arranged in order of execution of processing items and image processing is called a measurement flow. Processing items and measurement flows can have more than one setting. You can switch the setting based on the scene to inspect. (Refer to the *Vision System FH series 3D Robot Vision Application Construction Guide (Cat.No. Z446)* and *Vision System FH/FHV series User's Manual (Cat.No. Z365)*.)

---

## Concept of Measurement Processing

When the FH receives a measurement trigger from the PLC or other external device, the image input from a Camera, measurement processing, and output of measurement results (e.g., OK/NG judgement results) are executed in the order that those processing items are registered in the measurement flow.

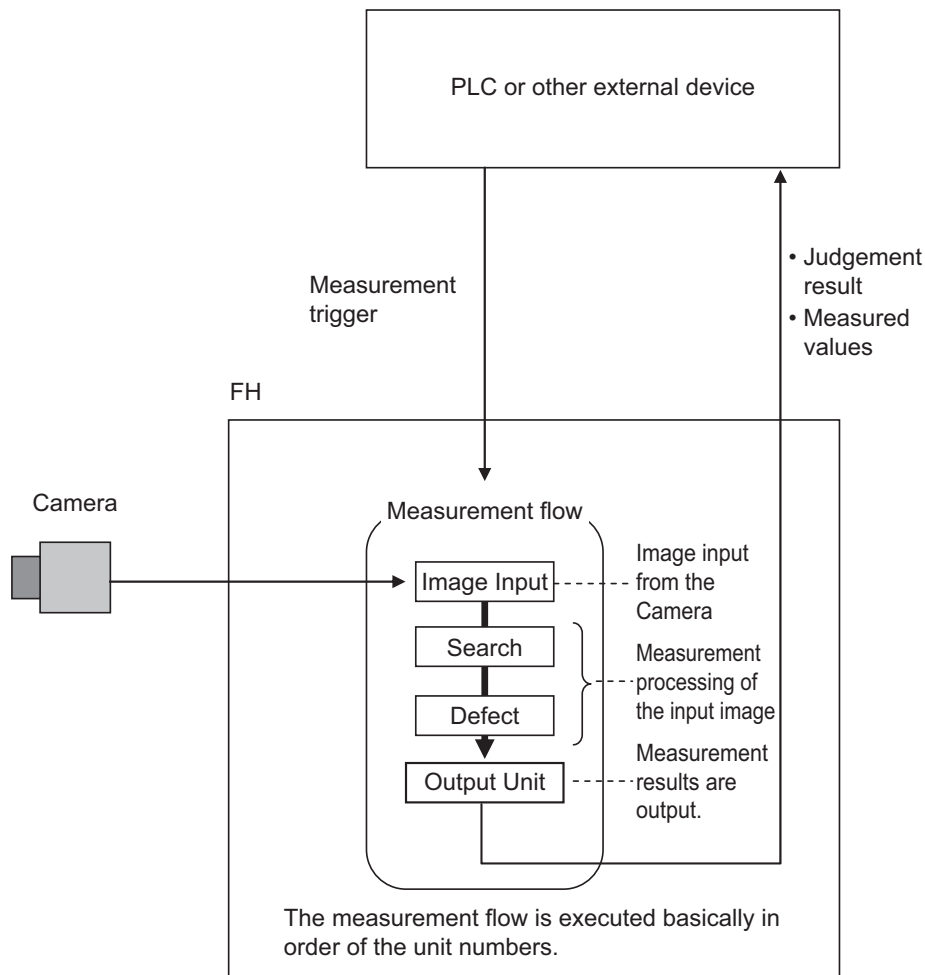

In the measurement flow, you can change the processing to execute based on the inspection results or input conditions of the vision inspection.

You can use macro processing to execute pre-packaged processing items and functions in the FH to create original programs. This allows you to create original measurement processes, display processing, input and output processing, and settings dialog boxes that are custom-tailored to your application.

## 2-1-1 System Configuration

### The Example of a System Configuration

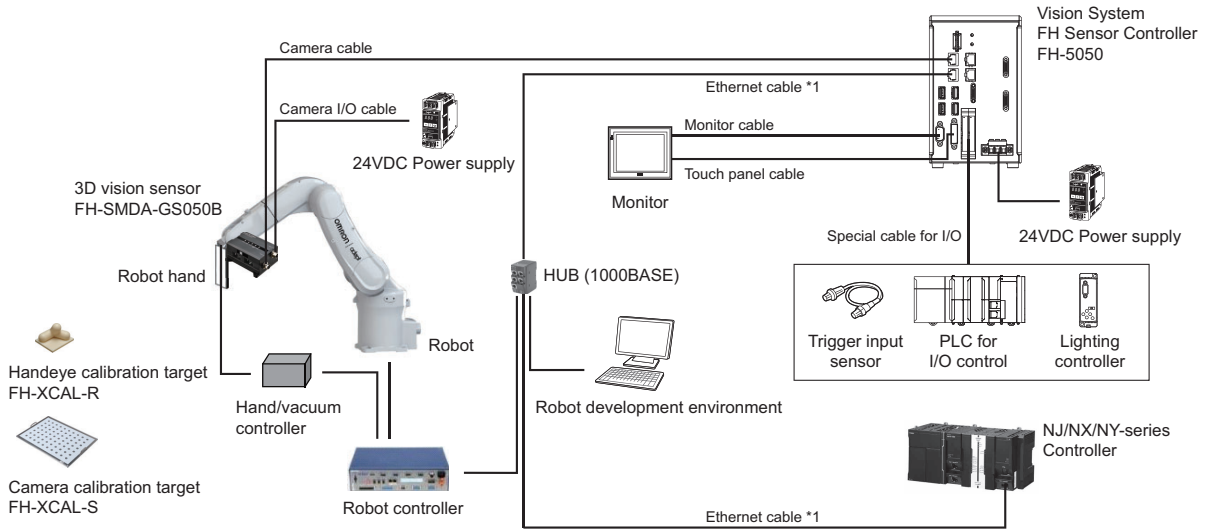

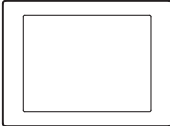
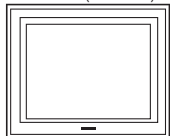
<p><b>Camera cable</b></p> <p>Straight Ethernet cable FHV-VNBX2 (5 m, 10 m, min. bending radius: 40 mm) FHV-VNBX (3 m, 5 m, 10 m, min. bending radius: 38 mm) Right-angle Ethernet cable FHV-VNLBX2 (5 m, 10 m, min. bending radius: 40 mm) FHV-VNLBX (3 m, 5 m, 10 m, min. bending radius: 38 mm)</p>	<p><b>Monitor</b></p> <p>Use the monitor to check images and display the condition-setting menus.</p> <p>LCD monitor FZ-M08 (8.4 inch)</p>  <p>Touch panel monitor FH-MT12 (12.1 inch)</p>  <p><b>Monitor cable</b></p> <p>FH-VMDA (2 m, 5 m, 10 m, min. bending radius 36 mm)</p> <p><b>Touch panel cable</b></p> <p>FH-VUAB (USB type, 2 m, 5 m, min. bending radius: 25 mm) XW2Z-□□PP-1 (RS-232C type, 2 m, 5 m, 10 m, min. bending radius: 59 mm)</p>	<p><b>Power Supply</b></p> <p>The power supply connected to FH Sensor Controller varies depending on the number of connected cameras and types for various consumption current types. Use is accordingly. Recommended Model by OMRON: S8VK-G series/S8VS series</p> <p>The power supply connected to 3D vision sensor varies for appropriate consumption current types. Use is accordingly. Recommended Model by OMRON: S8V-NFS206 or equivalent products</p> <p><b>Peripheral Device</b></p> <table border="0"> <tr> <td>USB flash drive</td> <td>SD Memory Card</td> </tr> <tr> <td>FZ-MEM2G</td> <td>HMC-SD292</td> </tr> <tr> <td>FZ-MEM8G</td> <td>HMC-SD492</td> </tr> <tr> <td>FZ-MEM16G</td> <td>NSD6-002GS(P11SEI)</td> </tr> <tr> <td></td> <td>NSD6-004GS(P11SEI)</td> </tr> </table> <p><b>Switcher</b></p> <p>In case of switching multiple of sensor controllers with a single monitor or touch panel monitor, please make sure to use an appropriate product. Recommended model by OMRON: FZ-DU</p> <p><b>Input Device</b></p> <p>Mouse, track ball (Commercially available USB devices)</p> <p><b>FH Application Software</b></p> <p>3D Robot Vision Software Installer FH-UM3D1</p>	USB flash drive	SD Memory Card	FZ-MEM2G	HMC-SD292	FZ-MEM8G	HMC-SD492	FZ-MEM16G	NSD6-002GS(P11SEI)		NSD6-004GS(P11SEI)
USB flash drive	SD Memory Card											
FZ-MEM2G	HMC-SD292											
FZ-MEM8G	HMC-SD492											
FZ-MEM16G	NSD6-002GS(P11SEI)											
	NSD6-004GS(P11SEI)											

\*1. To use STP (shielded twisted-pair) cable of category 5 or higher for Ethernet and RJ45 connector.



## 2-2 Flow of Use Procedure

The following table shows the flow for using the FH.

Procedure	Description	Reference
Preparations	Installation and Wiring	<i>Section 4 Handling and Installation Environment</i> on page 4-1 <i>Section 5 Setup and Wiring</i> on page 5-1
	↓	
	Turning ON Power	<i>5-1 When turning ON and OFF</i> on page 5-2
	↓	
	Language Selection in Dialog Box (only when the Sensor Controller is started for the first time)	<i>Vision System FH series 3D Robot Vision Application Construction Guide (Cat.No. Z446)</i> and <i>Vision System FH/FHV series User's Manual (Cat.No. Z365)</i>
	↓	
	Main Window (Layout 0) Display	<i>Vision System FH series 3D Robot Vision Application Construction Guide (Cat.No. Z446)</i> and <i>Vision System FH/FHV series User's Manual (Cat.No. Z365)</i>
	↓	
	Camera Adjustments (Display the settings dialog box for a Camera Image Input processing item.)	<i>Vision System FH series 3D Robot Vision Application Construction Guide (Cat.No. Z446)</i> and <i>Vision System FH/FHV series User's Manual (Cat.No. Z365)</i>
	↓	
	Select <b>Tool - System settings</b> , and then under <b>Startup setting</b> , set the settings for <i>Basic, Communication, and Operation mode</i> .	<i>Vision System FH series 3D Robot Vision Application Construction Guide (Cat.No. Z446)</i> and <i>Vision System FH/FHV series User's Manual (Cat.No. Z365)</i>
	↓	
	Click the <b>Data save</b> button, and then select <b>Function - System restart</b> .	<i>Vision System FH series 3D Robot Vision Application Construction Guide (Cat.No. Z446)</i> and <i>Vision System FH/FHV series User's Manual (Cat.No. Z365)</i>
↓		
Select <b>Tool - System settings</b> , and then set the settings for <i>Camera, Communication and Other</i> .	<i>Vision System FH series 3D Robot Vision Application Construction Guide (Cat.No. Z446)</i> and <i>Vision System FH/FHV series User's Manual (Cat.No. Z365)</i>	
↓		
Click the <b>Data save</b> button.	<i>Vision System FH series 3D Robot Vision Application Construction Guide (Cat.No. Z446)</i> and <i>Vision System FH/FHV series User's Manual (Cat.No. Z365)</i>	
↓		

Procedure	Description	Reference
Scene Editing	In the Main Window (layout 0), edit the measurement flow. <ul style="list-style-type: none"> <li>Register processing items.</li> <li>Set the properties for each processing item.</li> </ul>	<i>Vision System FH series 3D Robot Vision Application Construction Guide (Cat.No. Z446) and Vision System FH/FHV series User's Manual (Cat.No. Z365)</i>
	↓	
	Click the <b>Data save</b> button.	<i>Vision System FH series 3D Robot Vision Application Construction Guide (Cat.No. Z446) and Vision System FH/FHV series User's Manual (Cat.No. Z365)</i>
↓↑		
Testing	Execute test measurements. (In the Main Window (layout 0), click the <b>Measure</b> button.)	<i>Vision System FH series 3D Robot Vision Application Construction Guide (Cat.No. Z446) and Vision System FH/FHV series User's Manual (Cat.No. Z365)</i>
	↓	
	Adjust the parameters for each processing item.	<i>Vision System FH series Processing Item Function Reference Manual for 3D Robot Vision (Cat. No. Z445) and Vision System FH/FHV series Processing Item Function Reference Manual (Cat. No. Z341)</i>
	↓	
	Click the <b>Data save</b> button.	<i>Vision System FH series 3D Robot Vision Application Construction Guide (Cat.No. Z446) and Vision System FH/FHV series User's Manual (Cat.No. Z365)</i>
↓		
Measuring (Operation)	In the Main Window (layout 0), click the <b>Switch layout</b> button, and then select <i>Main Window (Layout 1)</i> .	<i>Vision System FH series 3D Robot Vision Application Construction Guide (Cat.No. Z446) and Vision System FH/FHV series User's Manual (Cat.No. Z365)</i>
	↓	
	In the Main Window (layout 1), check the communications with the PLC.	<i>Vision System FH/FHV series User's Manual for Communications Settings (Cat. No. Z342)</i>
	↓	
	In the Main Window (layout 1), execute commands from the PLC, such as measurement trigger commands.	<i>Vision System FH/FHV series User's Manual for Communications Settings (Cat. No. Z342)</i>
↓		
Management and Analysis	Save and analyze measurement data and images.	<i>Vision System FH series 3D Robot Vision Application Construction Guide (Cat.No. Z446) and Vision System FH/FHV series User's Manual (Cat.No. Z365)</i>

# 3

## Configuration

---

<b>3-1</b>	<b>Sensor Controller .....</b>	<b>3-2</b>
3-1-1	FH-5050 .....	3-2
<b>3-2</b>	<b>Camera and Cables .....</b>	<b>3-9</b>
3-2-1	3D Vision Sensor .....	3-9
3-2-2	Camera Cable .....	3-13
3-2-3	Camera I/O Cable .....	3-17
<b>3-3</b>	<b>Calibration Target .....</b>	<b>3-19</b>
<b>3-4</b>	<b>Touch Panel Monitor and Cable .....</b>	<b>3-21</b>
<b>3-5</b>	<b>LCD and Cable .....</b>	<b>3-27</b>

# 3-1 Sensor Controller

## 3-1-1 FH-5050

### Specification

#### ● FH-5050 for 3D Robot Vision

Series		FH-5000 Series		
Type		High-speed, Large-capacity Controller(4 cores)		
Model		FH-5050		
Controller Type		Box type		
Parallel IO polarity		NPN/PNP (common)		
Main Functions	Operation Mode	Standard	Yes	
		Double Speed Multi-input	No	
		Non-stop adjustment mode	No	
		Multi-line random-trigger mode	No	
	Parallel Processing		Yes	
	Number of Connectable Camera		1 (Connect to the Ethernet port.)	
	Supported Camera		FH-SMDA-GS050B	
	Possible Number of Logging Images to Sensor Controller		Both 3D and 2D imaging: Up to 14 images 3D imaging only, 2D imaging only: Up to 29 images	
	Possible Number of Scenes		Approximately 10 scenes (Varies depending on usage conditions.)	
	Operating on UI	USB Mouse	Yes (wired USB and driver is unnecessary type)	
		Touch Panel	Yes (RS-232C/USB connection: FH-MT12)	
	Setup		Create the processing flow using Flow editing.	
	Language		Japanese, English	
	External Interface	Serial Communication		RS-232C x 1
Ethernet Communication		Protocol	Non-procedure (TCP/UDP)	
		I/F	1000BASE-T x 2	
EtherNet/IP Communication		Yes (Target/Ethernet port)		
PROFINET Communication		<ul style="list-style-type: none"> <li>• Yes (Slave/Ethernet port)</li> <li>• Conformance class A</li> </ul>		
EtherCAT Communication		Yes (slave)		
Parallel I/O		9 inputs/22 outputs		
Encoder Interface		Not supported.		
Monitor Interface		DVI-I output (Analog RGB & DVI-D single link) x 1		
USB I/F		USB2.0 host x 2 (BUS Power: 5 V/0.5 A per port) USB3.0 host x 2 (BUS Power: 5 V/0.9 A per port)		

Series		FH-5000 Series	
Type		High-speed, Large-capacity Controller(4 cores)	
Model		FH-5050	
	SD Card I/F	SDHC x 1	
Indicator Lamps	Main	POWER: Green ERROR: Red RUN: Green ACCESS: Yellow	
	Ethernet	NET RUN1: Green LINK/ACT1: Yellow NET RUN2: Green LINK/ACT2: Yellow	
	SD Card	SD POWER: Green SD BUSY: Yellow	
	EtherCAT	ECAT RUN: Green LINK/ACT IN: Green LINK/ACT OUT: Green ECAT ERR: Red	
Supply Voltage		20.4 VDC to 26.4 VDC	
Current consumption		4.2A max.	
Built-in FAN		Yes	
Usage Environment	Ambient temperature range		Operating: 0°C to +45°C Storage: -20 to +65°C (with no icing or condensation)
	Ambient humidity range		Operating and storage: 35 to 85% (with no condensation)
	Ambient atmosphere		No corrosive gases
	Vibration tolerance		Oscillation frequency: 10 to 150 Hz, Half amplitude: 0.1 mm, Acceleration: 15 m/s <sup>2</sup> Sweep time: 8 minute/count, Sweep count: 10, Vibration direction: up and down/front and behind/left and right
	Shock resistance		Impact force: 150 m/s <sup>2</sup> Test direction: up and down/front and behind/left and right
	Noise immunity	Fast Transient Burst	<ul style="list-style-type: none"> <li>DC power: Direct infusion: 2 kV, Pulse rising: 5 ns, Pulse width: 50 ns, Burst continuation time: 15 ms/0.75 ms, Period: 300 ms, Application time: 1 min.</li> <li>I/O line: Direct infusion: 1 kV, Pulse rising: 5 ns, Pulse width: 50 ns, Burst continuation time: 15 ms/0.75 ms, Period: 300 ms, Application time: 1 min.</li> </ul>
	Grounding		Class D grounding (100 Ω or less grounding resistance) *1

Series		FH-5000 Series
Type		High-speed, Large-capacity Controller(4 cores)
Model		FH-5050
External Features	Dimensions	190 mm x 115 mm x 182.5 mm Note Height: Including the rubber at the base.
	Weight	Approx.3.4kg
	Degree of protection	IEC60529 IP20
	Case material	Cover: zinc-plated steel plate, Side plate: aluminum (A6063)

\*1. Existing the third class grounding

## Component Names and Functions

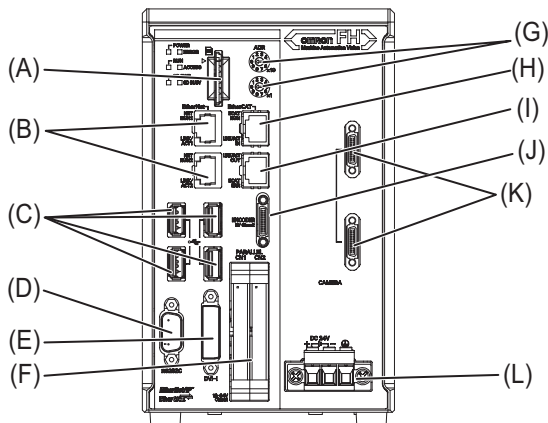

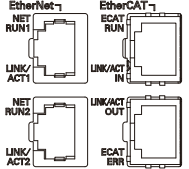
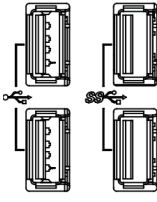
	Connector name	Description
(A)	SD memory card installation connector	Install the SD memory card. Do not plug or unplug the SD memory card during measurement operation. Otherwise measurement time may be affected or data may be destroyed.
(B)	Ethernet connector	<p>Connect an Ethernet device.</p> <div data-bbox="603 969 1366 1182" style="border: 1px solid black; padding: 5px;"> <p>Upper port : Ethernet port Lower port : Ethernet port, EtherNet/IP port, and PROFINET port are sharing use.</p>  </div> <p>Connect the camera cable (Ethernet cable FHV-VN□BX: sold separately) to the upper port.</p>
(C)	USB connector	<p>Connect a USB device. Do not plug or unplug it during measurement. Otherwise measurement time may be affected or data may be destroyed.</p> <div data-bbox="603 1379 1366 1720" style="border: 1px solid black; padding: 5px;"> <p>Left ports: USB2.0 Right ports: USB3.0</p> <p>The USB3.0 interface has a higher bus power supply capability than the USB2.0 interface, and you can expect more stable operation with it.</p> <p>Also, when used in combination with a USB3.0 device, you can expect higher transfer speed than USB2.0. Be sure to give priority to using the USB3.0 interface.</p>  </div>
(D)	RS-232C connector	Connect an external device such as a touch panel monitor.
(E)	DVI-I connector	Connect a monitor.
(F)	I/O (Parallel) connector (control lines, data lines)	Connect the controller to external devices such as a sync sensor and PLC.
(G)	EtherCAT address setup volume	Used to set a station address (00 to 99) as an EtherCAT communication device.

	Connector name	Description
(H)	EtherCAT communication connector (IN)	Connect the opposed EtherCAT device.
(I)	EtherCAT communication connector (OUT)	Connect the opposed EtherCAT device.
(J)	Encoder connector	Not supported.
(K)	Camera connector	Not supported. Do not connect cameras.
(L)	Power supply terminal connector	Connect a DC power supply. Wire the FH Sensor Controller independently on other devices. Wire the ground line. Be sure to ground the FH Sensor Controller alone. Use an attachment power terminal (male) for installation. For details, refer to 5-3 <i>Sensor Controller Installation</i> on page 5-5.

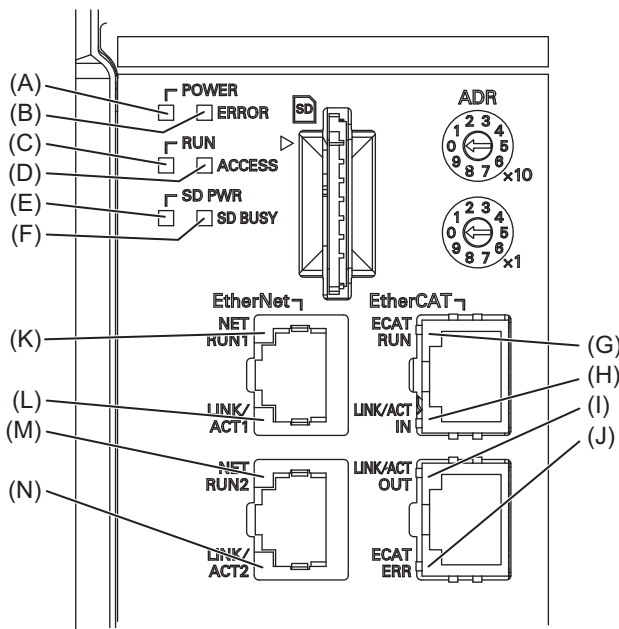

	LED name	Description
(A)	POWER LED	Lit while power is ON.
(B)	ERROR LED	Lit when an error has occurred.
(C)	RUN LED	Lit while the layout turned on output setting is displayed.
(D)	ACCESS LED	Blinks while the internal nonvolatile memory is accessed.
(E)	SD POWER LED	Lit while power is supplied to the SD memory card and the card is usable.
(F)	SD BUSY LED	Blinks while the SD memory card is accessed.
(G)	EtherCAT RUN LED	Lit while EtherCAT communications are usable.
(H)	EtherCAT LINK/ACT IN LED	Lit when connected with an EtherCAT device, and blinks while performing communications.
(I)	EtherCAT LINK/ACT OUT LED	Lit when connected with an EtherCAT device, and blinks while performing communications.
(J)	EtherCAT ERR LED	Lit when EtherCAT communications have become abnormal.



	LED name	Description
(K)	Ethernet NET RUN1 LED	Lit while Ethernet communications are usable.
(L)	Ethernet LINK/ACT1 LED	Lit when connected with an Ethernet device, and blinks while performing communications.
(M)	Ethernet NET RUN2 LED	Lit while Ethernet communications are usable.
(N)	Ethernet LINK/ACT2 LED	Lit when connected with an Ethernet device, and blinks while performing communications.

## EtherCAT status indicator LED

Detailed LED specifications are given below.

LED name	Color	Status	Contents
ECAT RUN	Green	OFF	Initialization status
		Blinking	Pre-Operational status
		Single flash	Safe-Operational status
		ON	Operational status
ECAT ERROR	Red	OFF	No error
		Blinking	Communication setting error or PDO mapping error
		Single flash	Synchronization error or communications data error
		Double flash	Application WDT timeout
		ON	PDI WDT timeout
L/A IN	Green	OFF	Link not established in physical layer
		Flickering	In operation after establishing link
		ON	Link established in physical layer
L/A OUT	Green	OFF	Link not established in physical layer
		Flickering	In operation after establishing link
		ON	Link established in physical layer

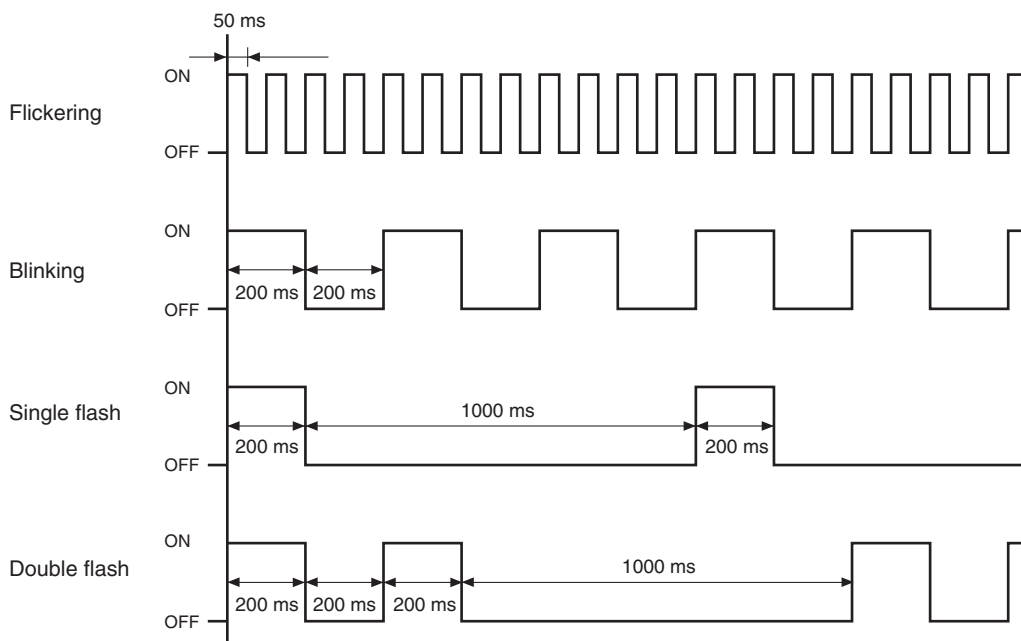

## Dimensions

Sensor Controllers  
FH-series Box-type  
FH-5050

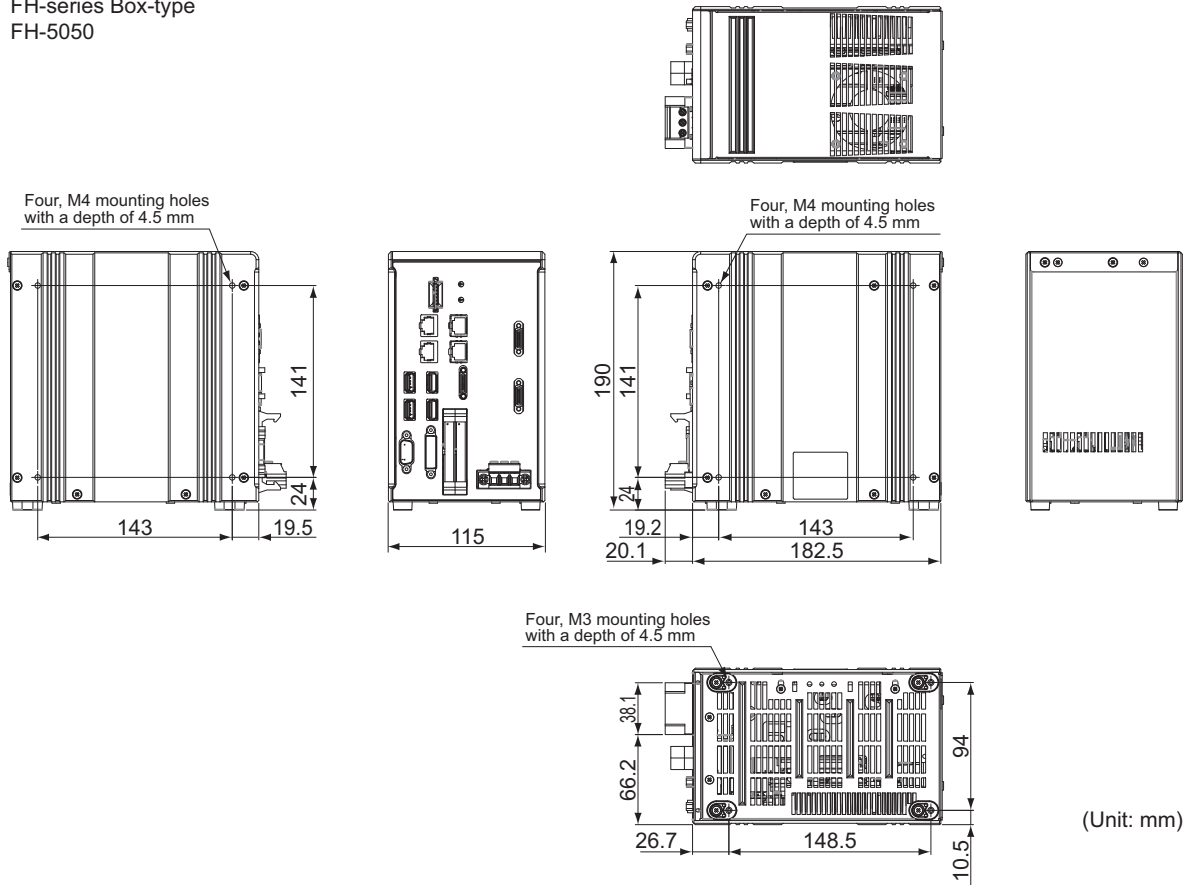

### Additional Information

We have the 2D CAD data or 3D CAD data.  
You can download CAD data from [www.fa.omron.co.jp](http://www.fa.omron.co.jp).

## 3-2 Camera and Cables

### 3-2-1 3D Vision Sensor

#### Specification

Model		FH-SMDA-GS050B
Image elements		CMOS image elements
Color/Monochrome		Monochrome
Effective pixels		1296(H) x 972(V)
Shutter function		Electronic shutter, Shutter speeds can be set from 1 ms to 50 ms.
Measurement range (X,Y,Z)		400 x 300 x 200 mm
Installation distance		WD: 400 mm
Lighting for 2D	Lighting color	blue
	LED class	Group 2 (IEC62471)
Lighting for 3D	Lighting color	blue
	LED class	Group 2 (IEC62471)
Indicator Lamps		PWR: Green LINK: Green ACT: Yellow WARM UP: Yellow ERR: Red
External I/F	FH controller connection	GigE (1000BASE-T) x 1 100Base cannot be used. PoE is not available.
	Power supply, Input / output	Power supply: DC24V I/O: -
Warming up time		15 minutes or less
Supply Voltage		21.6 VDC to 26.4 VDC (24VDC $\pm$ 10%)
Current consumption		2A max.
Vibration tolerance		Oscillation frequency: 10 to 150 Hz, Half amplitude: 0.35 mm, Sweep time: 8 minute/count, Sweep count: 10, Vibration direction: X/Y/Z
Shock resistance		Impact force: 150 m/s <sup>2</sup> , Test direction: up and down/front and behind/left and right
Ambient temperature range		Operating: 0°C to +40°C Storage: -25 to +60°C (with no icing or condensation)
Ambient humidity range		Operating and storage: 35 to 85% (with no condensation)
Ambient atmosphere		No corrosive gases
Grounding		Class D grounding (100 $\Omega$ or less grounding resistance) <sup>*1</sup>
Dimensions		53 mm x 110 mm x 77 mm (Excluding protrusions and connectors)
Degree of protection		IEC60529 IP60
Material		Aluminium (A5052)
Weight		Approx. 570g
Accessories		<ul style="list-style-type: none"> <li>• Instruction Sheet</li> <li>• General Compliance Information and Instructions for EU</li> </ul>

\*1. Existing the third class grounding



### Precautions for Correct Use

- This camera cannot be used as a measuring instrument, because it is not an absolute distance. Use in combination with robot calibration.
- If there are slight unevennesses, it cannot be recognized. There must consist of a surface of 20 x 20 mm or more
- The minimum recognition workpiece thickness is 5 mm or more.
- If the surface is strongly glossy and the reflection is strong, it cannot be recognized.

## Component Names and Functions

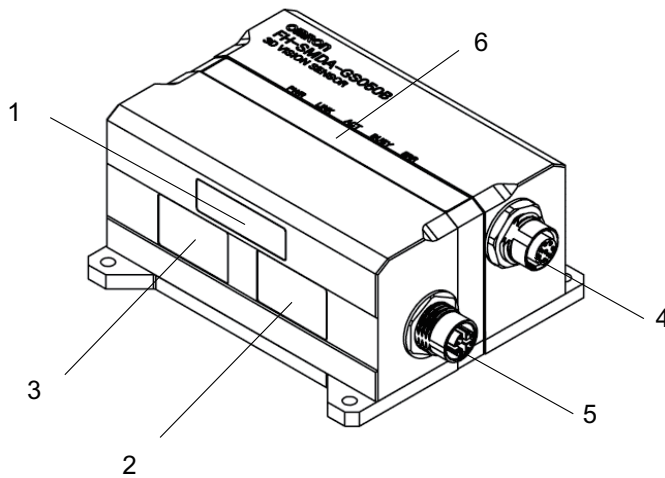

	Name		Description
1	2D lighting unit		Lighting for 2D measurement is arranged to illuminate the light.
2	3D lighting unit		Pattern lighting for 3D measurement is arranged to illuminate the light.
3	Imaging unit		Captures images.
4	Connector for camera I/O cable		Use this connector when connecting the camera with a power supply using a camera I/O cable. Dedicated camera I/O cable: FH-VSDX-BX / FH-VSDX-LBX)
5	Connector for camera cable (Ethernet cable)		Use this connector when connecting the camera with a FH sensor controller using an camera cable (Ethernet cable). Dedicated camera cable (Ethernet cable): FHV-VNBX2 / FHV-VNLBX2 / FHV-VNBX / FHV-VNLBX)
6	Operation indicator	PWR (Green)	Lights while power is supplied.
		LINK (Green)	Lights when connected with Ethernet equipment.
		ACT (Yellow)	Blinks while communicating with an Ethernet device.
		WARM UP (Yellow)	Lights from startup to completion of warming up. Turns off after warming up.
		ERR (Red)	Lights when an error occurs. For the error (system error), refer to the <b>Camera Image Input AOS</b> in the <i>Vision System FH series Processing Item Function Reference Manual for 3D Robot Vision (Cat. No. Z445)</i> .

## Dimensions

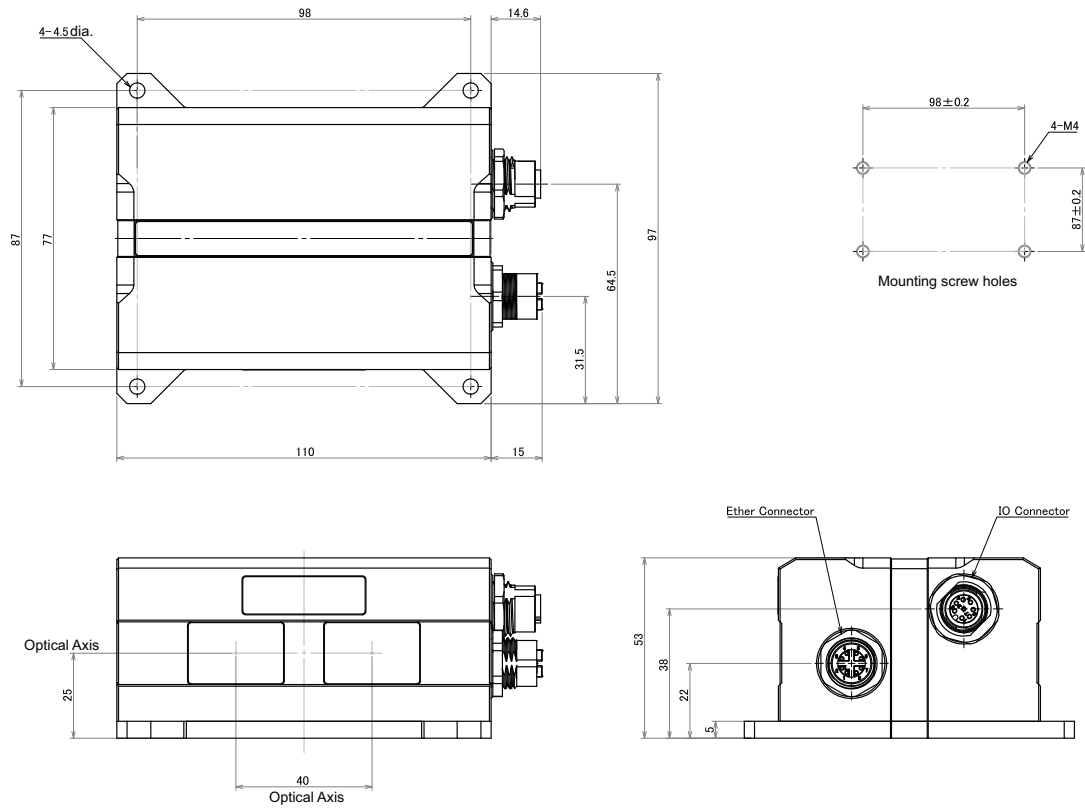

(Unit: mm)

## Measurement Range and Field of View

•Measurement range

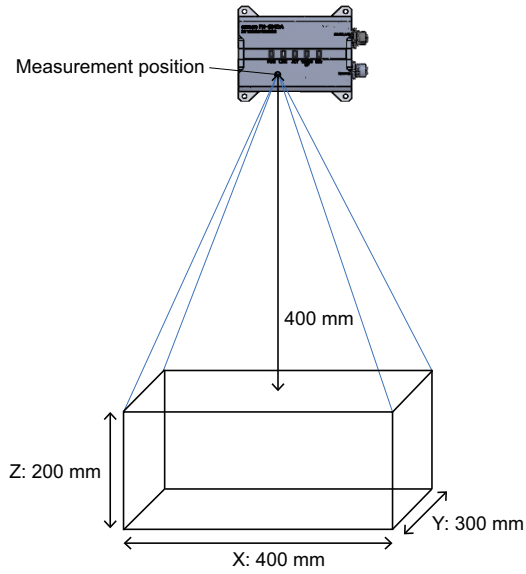

Measurement range (X,Y,Z)	400x300x200 mm
WD	400 mm

•Measurement position

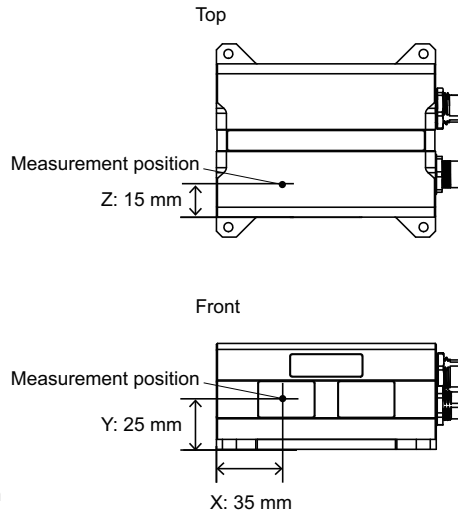

## 3-2-2 Camera Cable

### Specification

- Camera cable (Ethernet, straight)

Item		FHV-VNBX2 5M	FHV-VNBX2 10M
Cable length		5 m	10 m
Cable type		Bending resistance cable	
Connector type		Straight connector	
Outer diameter		6.6 + 0.7 mm dia.	
Min. bending radius		40 mm	
Usage environ- ment	Ambient temper- ature range	Operating: -10 to +70°C, Storage: -25 to +85°C (with no icing or conden- sation)	
	Ambient humidi- ty range	Operating & Storage: 0 to 93% (With no condensation)	
	Ambient atmos- phere	No corrosive gases	
	Vibration toler- ance	Oscillation frequency: 10 to 150Hz, Half amplitude: 0.35 mm, Vibration di- rection: X/Y/Z, Sweep time: 8 minutes/count, Sweep count: 10 times	
	Shock resist- ance	Impact force: 150 m/s <sup>2</sup> , Test direction: 6 directions, three time each (up/ down, front/behind, left/right)	
Material		Mold part: PVC, Sheath part: PVC	
Weight		Approx. 390 g	Approx. 730 g

Item		FHV-VNBX 3M	FHV-VNBX 5M	FHV-VNBX 10M
Cable length		3 m	5 m	10 m
Cable type		Bending resistance cable		
Connector type		Straight connector		
Outer diameter		6.3 + 0.6 mm dia.		
Min. bending radius		38 mm		
Usage environ- ment	Ambient temper- ature range	Operating: -30 to +80°C, Storage: -30 to +100°C (with no icing or conden- sation)		
	Ambient humidi- ty range	Operating & Storage: 0 to 93% (With no condensation)		
	Ambient atmos- phere	No corrosive gases		
	Vibration toler- ance	Oscillation frequency: 10 to 150Hz, Half amplitude: 0.35 mm, Vibration di- rection: X/Y/Z, Sweep time: 8 minutes/count, Sweep count: 10 times		
	Shock resist- ance	Impact force: 150 m/s <sup>2</sup> , Test direction: 6 directions, three time each (up/ down, front/behind, left/right)		
Material		Mold part: Nylon, Thermoplastic polyurethane, Sheath part: Low friction PVC		
Weight		Approx. 220 g	Approx. 330 g	Approx. 590 g

- Camera cable (Ethernet, right angle)

Item		FHV-VNLBX2 5M	FHV-VNLBX2 10M
Cable length		5 m	10 m
Cable type		Bending resistance cable	
Connector type		Right angle connector	
Outer diameter		6.6 + 0.7 mm dia.	
Min. bending radius		40 mm	
Usage environment	Ambient temperature range	Operating: -10 to +70°C, Storage: -25 to +85°C (with no icing or condensation)	
	Ambient humidity range	Operating & Storage: 0 to 93% (With no condensation)	
	Ambient atmosphere	No corrosive gases	
	Vibration tolerance	Oscillation frequency: 10 to 150Hz, Half amplitude: 0.35 mm, Vibration direction: X/Y/Z, Sweep time: 8 minutes/count, Sweep count: 10 times	
	Shock resistance	Impact force: 150 m/s <sup>2</sup> , Test direction: 6 directions, three time each (up/down, front/behind, left/right)	
Material		Mold part: PVC, Sheath part: PVC	
Weight		Approx. 390 g	Approx. 730 g

Item		FHV-VNLBX 3M	FHV-VNLBX 5M	FHV-VNLBX 10M
Cable length		3 m	5 m	10 m
Cable type		Bending resistance cable		
Connector type		Right angle connector		
Outer diameter		6.3 + 0.6 mm dia.		
Min. bending radius		38 mm		
Usage environment	Ambient temperature range	Operating: -30 to +80°C, Storage: -30 to +100°C (with no icing or condensation)		
	Ambient humidity range	Operating & Storage: 0 to 93% (With no condensation)		
	Ambient atmosphere	No corrosive gases		
	Vibration tolerance	Oscillation frequency: 10 to 150Hz, Half amplitude: 0.35 mm, Vibration direction: X/Y/Z, Sweep time: 8 minutes/count, Sweep count: 10 times		
	Shock resistance	Impact force: 150 m/s <sup>2</sup> , Test direction: 6 directions, three time each (up/down, front/behind, left/right)		
Material		Mold part: Nylon, Thermoplastic polyurethane, Sheath part: Low friction PVC		
Weight		Approx. 220 g	Approx. 330 g	Approx. 590 g



## Dimensions

- Ethernet cable (straight)

FHV-VNBX2

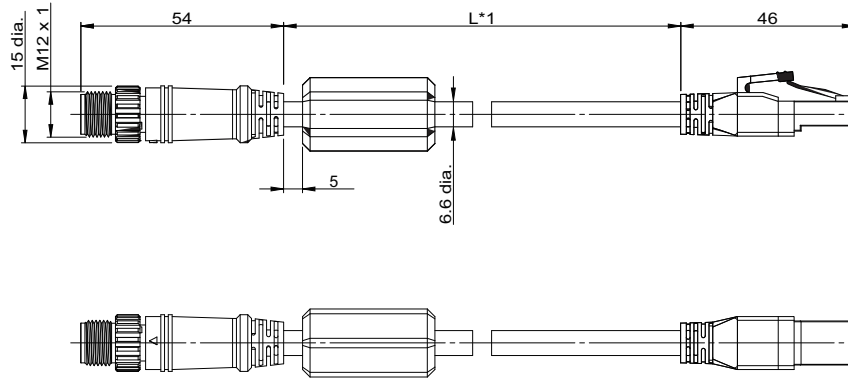

(Unit: mm)

\*1. Cable lengths (L) are 5 m/10 m.

FHV-VNBX

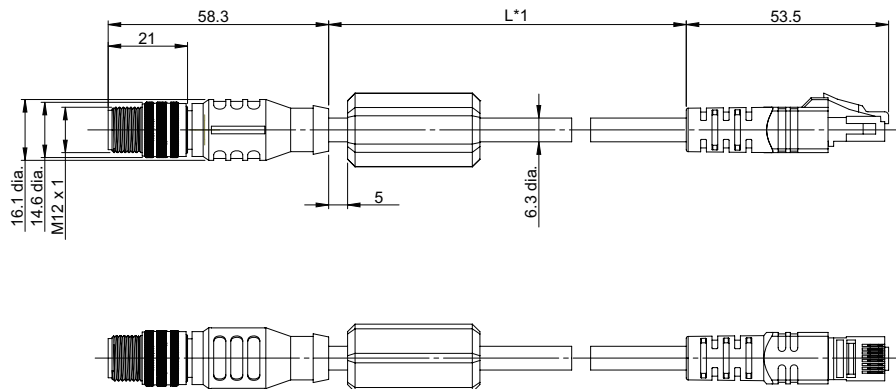

(Unit: mm)

\*1. Cable lengths (L) are 3 m/5 m/10 m.

- Ethernet cable (right angle)

## FHV-VNLBX2

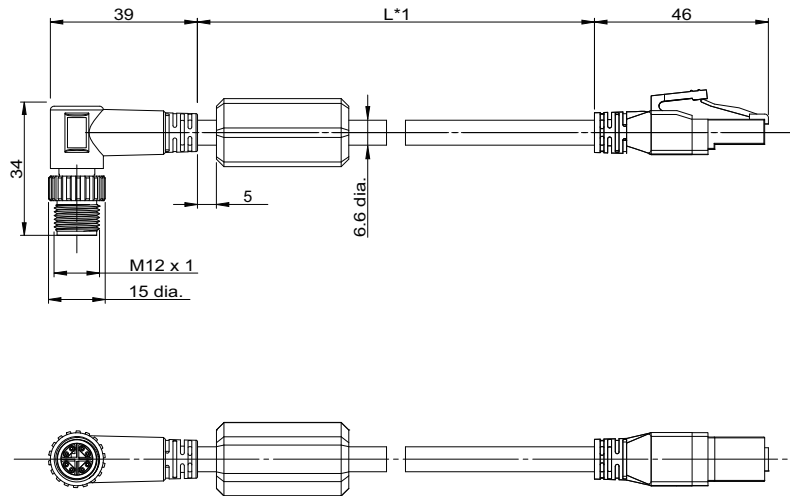

(Unit: mm)

\*1. Cable lengths (L) are 5 m/10 m.

## FHV-VNLBX

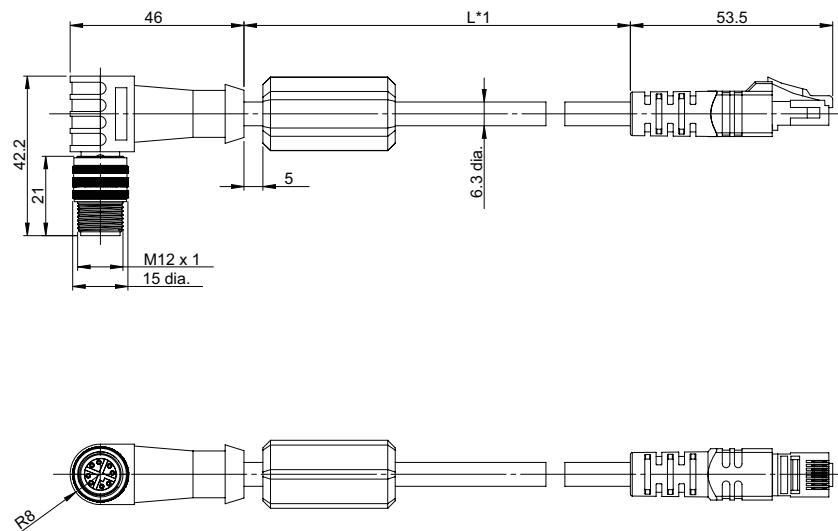

(Unit: mm)

\*1. Cable lengths (L) are 3 m/5 m/10 m.



### Additional Information

We have the 2D CAD data or 3D CAD data.  
You can download CAD data from [www.fa.omron.co.jp](http://www.fa.omron.co.jp).

### 3-2-3 Camera I/O Cable

#### Specification

- Camera I/O cable (straight)

Item		FH-VSDX-BX 3M	FH-VSDX-BX 5M	FH-VSDX-BX 10M
Cable length		3 m	5 m	10 m
Cable type		Bending resistance cable		
Connector type		Straight connector		
Size		AWG26		
Outer diameter		5.8 mm dia.		
Min. bending radius		35 mm		
Usage environ- ment	Ambient temper- ature range	Operating: 0°C to +80°C, Storage: -20 to +80°C (with no icing or conden- sation)		
	Ambient humidi- ty range	Operating & Storage: 0 to 93% (With no condensation)		
	Ambient atmos- phere	No corrosive gases		
	Vibration toler- ance	Oscillation frequency: 10 to 150Hz, Half amplitude: 0.35 mm, Vibration di- rection: X/Y/Z, Sweep time: 8 minutes/count, Sweep count: 10 times		
	Shock resist- ance	Impact force: 150 m/s <sup>2</sup> , Test direction: 6 directions, three time each (up/ down, front/behind, left/right)		
Material		Shell: Zinc alloy, brass, Sheath part: oil-resistant and heat-resistant poly- vinyl chloride		
Weight		Approx. 220 g	Approx. 320 g	Approx. 570 g

- Camera I/O cable (right angle)

Item		FH-VSDX-LBX 3M	FH-VSDX-LBX 5M	FH-VSDX-LBX 10M
Cable length		3 m	5 m	10 m
Cable type		Bending resistance cable		
Connector type		Right angle connector		
Size		AWG26		
Outer diameter		5.8 mm dia.		
Min. bending radius		35 mm		
Usage environ- ment	Ambient temper- ature range	Operating: 0°C to +80°C, Storage: -20 to +80°C (with no icing or conden- sation)		
	Ambient humidi- ty range	Operating & Storage: 0 to 93% (With no condensation)		
	Ambient atmos- phere	No corrosive gases		
	Vibration toler- ance	Oscillation frequency: 10 to 150Hz, Half amplitude: 0.35 mm, Vibration di- rection: X/Y/Z, Sweep time: 8 minutes/count, Sweep count: 10 times		
	Shock resist- ance	Impact force: 150 m/s <sup>2</sup> , Test direction: 6 directions, three time each (up/ down, front/behind, left/right)		
Material		Shell: Zinc alloy, brass, Sheath part: oil-resistant and heat-resistant poly- vinyl chloride		
Weight		Approx. 230 g	Approx. 330 g	Approx. 580 g

## Dimensions

- Camera I/O cable (straight)

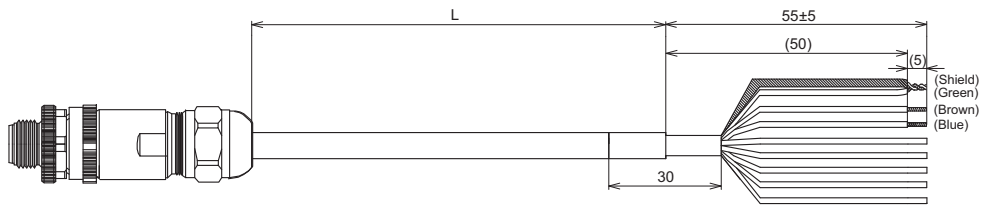

(Unit: mm)

- \*1. Cable lengths (L) are 3 m/5 m/10 m.

- Camera I/O cable (right angle)

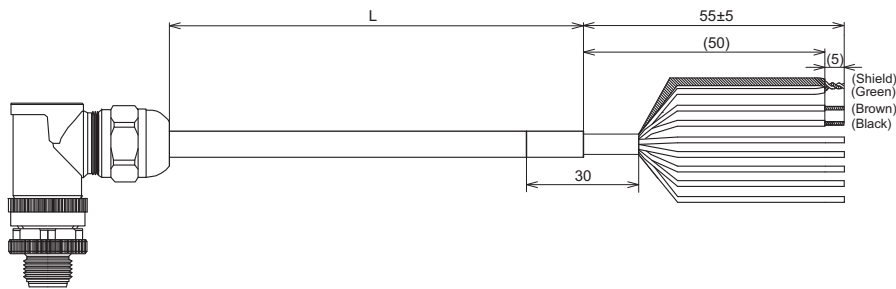

(Unit: mm)

- \*1. Cable lengths (L) are 3 m/5 m/10 m.



### Additional Information

We have the 2D CAD data or 3D CAD data.  
You can download CAD data from [www.fa.omron.co.jp](http://www.fa.omron.co.jp).

## 3-3 Calibration Target

### Specification

Model	FH-XCAL-R	FH-XCAL-S
Name	HandEye calibration target	Camera calibration target
Ambient temperature range	-25 to +65°C (with no icing or condensation)	
Ambient humidity range	35 to 85% (with no condensation)	
Ambient atmosphere	No corrosive gases	
Vibration tolerance	Oscillation frequency: 10 to 150 Hz, Half amplitude: 0.35 mm, Sweep time: 8 minute/count, Sweep count: 10, Vibration direction: X/Y/Z	
Shock resistance	Impact force: 150 m/s <sup>2</sup> , Test direction: up and down/front and behind/left and right	
Dimensions	65 mm × 55 mm × 42.4 mm	350 mm × 470 mm × 25 mm
Material	ABS	Aluminium
Weight	Approx. 50 g	Approx. 1,400 g
Accessories	-	-

### Dimensions

- HandEye calibration target (FH-XCAL-R)

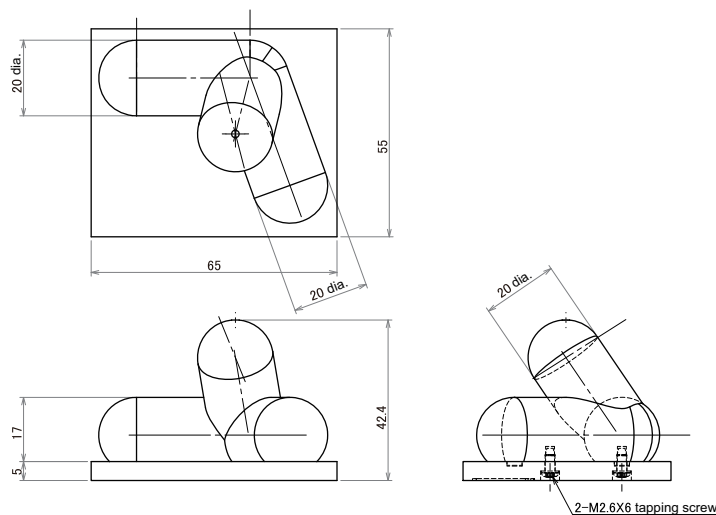

(Unit: mm)

- Camera calibration target (FH-XCAL-S)

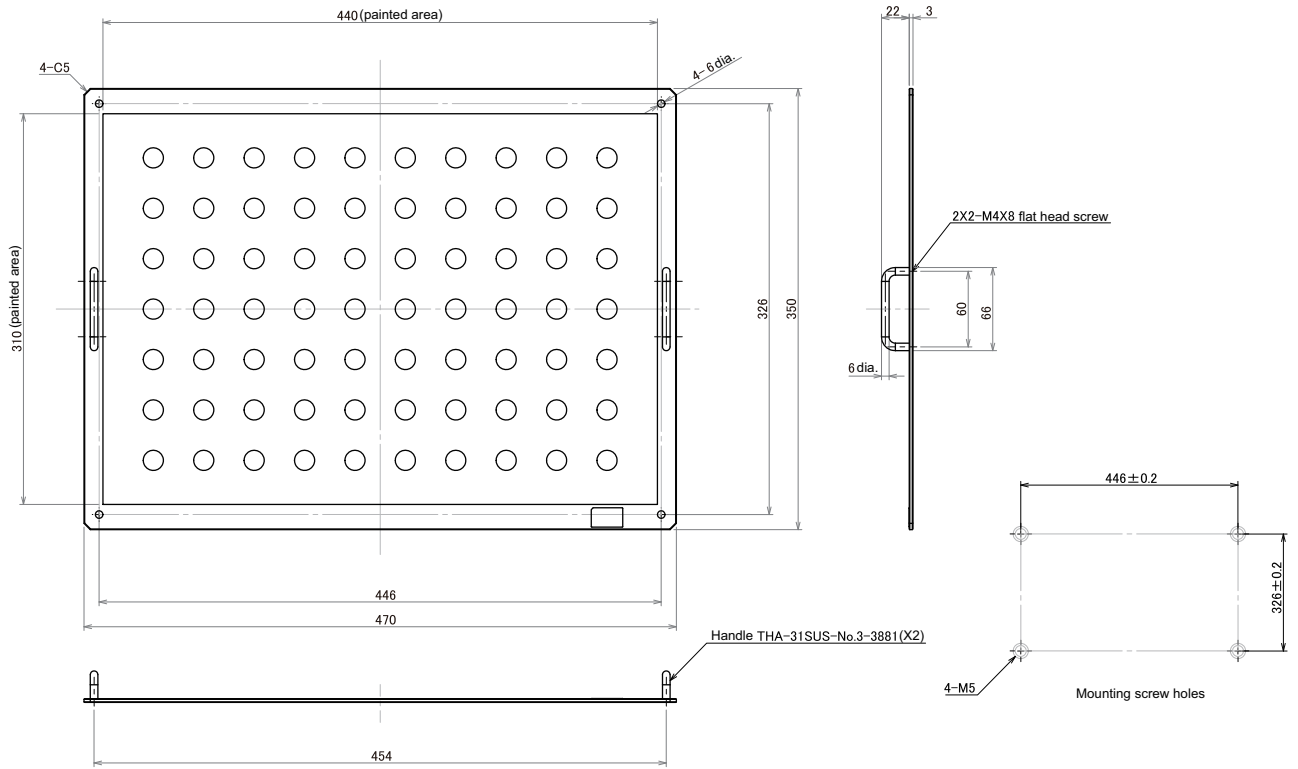

(Unit: mm)



### Additional Information

We have the 2D CAD data or 3D CAD data.  
 You can download CAD data from [www.fa.omron.co.jp](http://www.fa.omron.co.jp).

## 3-4 Touch Panel Monitor and Cable

Touch Panel Monitor of FH-MT12 is connectable with FH Sensor Controller whose software is Ver. 5.32 or later.

For connection of Touch Panel Monitor and FH Sensor Controller, the monitor cable for video and touch panel cable are necessary.



### Precautions for Safe Use

#### About connection of Sensor Controller and FH-MT12.

- Do not ground the plus (+) terminal of the 24 VDC power source when the Sensor Controller is connected to the FH-MT12 with a USB cable. Doing so may cause a short circuit of the internal circuit, resulting in a malfunction.

## Touch Panel Monitor

### ● Specification

Model		FH-MT12
Major Function	Display area	12.1 inch
	Resolution	1024 (V) x 768 (H)
	Number of color	16,200,000 colors (8 bit/color)
	Brightness	500 cd/m <sup>2</sup> (Typ)
	Contrast Ratio	700 : 1 (Typ)
	Viewing angle	Horizontal (left and right): -80° to 80° (typ) Vertical (top and bottom): -70° to 70° (typ)
	Backlight Unit	LED, edge-light
	Backlight lifetime	About 100,000 hour
	Touch panel	4 wire resistive touch screen
External interface	Video input	analog RGB
	Touch panel signal	USB, RS-232C
Ratings	Supply Voltage	24 VDC ±10 %
	Current consumption	0.5 A
	Insulation resistance	Between DC power supply and Touch Panel Monitor FG: 20 MΩ or higher (rated voltage 250 V)
Usage Environment	Ambient temperature range	Operating: 0 to +50°C, Storage: -20 to +65°C (with no icing or condensation)
	Ambient humidity range	Operating and Storage: 20 to 90% (with no icing or condensation)
	Ambient atmosphere	No corrosive gases
	Vibration tolerance	10 to 150 Hz, one-side amplitude 0.1 mm (Max. acceleration 15 m/s <sup>2</sup> ), 10 times for 8 minutes for each three direction
	Degree of protection	Panel mounting: IP65 on the front
Operation		Touch pen
Structure	Mounting	Panel mounting, VESA mounting
	Weight	Approx. 2.4 kg
	Case material	Front panel: PC/PBT, Front Sheet: PET, Rear case: SUS

## Component Names and Functions

### •Front view

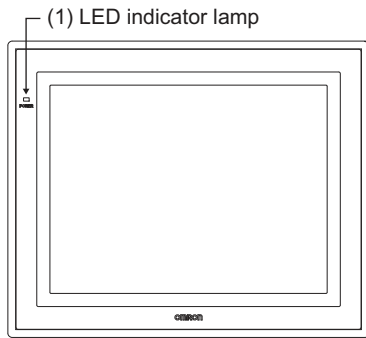

### •Rear view

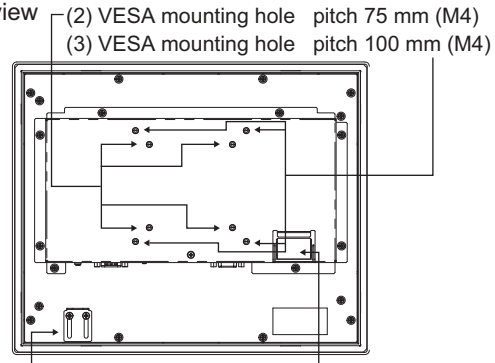

### •Connection terminal

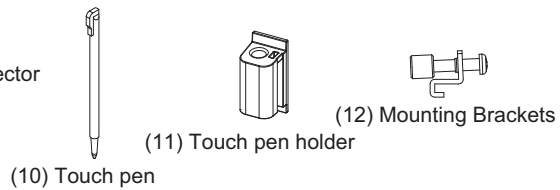
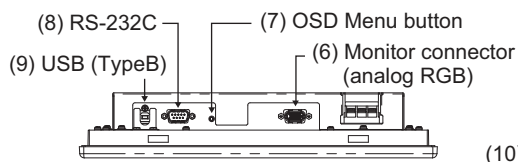

	Name	Description
(1)	LED indicator lamp	Lit up green when power is ON. Lit up orange when video signal is no input. Unlit when power is OFF.
(2)	VESA mounting hole (M4)	Mounting hole for VESA 75 mm x 75 mm.
(3)	VESA mounting hole (M4)	Mounting hole for VESA 100 mm x 100 mm.
(4)	USB retaining bracket	Retaining bracket for USB cable.
(5)	Power supply terminal	Connect a 24 VDC power supply.
(6)	Monitor connector (analog RGB)	Connect a monitor cable for analog RGB.
(7)	OSD Menu button	The button to activate the OSD menu.
(8)	RS-232C	Connect a serial communication port for touch panel communication.
(9)	USB (TypeB)	Connect a USB port (Type B) for touch panel communication.
(10)	Touch pen	Use for operation of touch panel.
(11)	Touch pen holder	Put touch pen in it when not using. Paste it on the monitor by double-sided tape.
(12)	Mounting Brackets	Use them to mount the panel.

For operation at launch OSD, refer to the Model FH-MT12 INSTRUCTION SHEET.



## Touch Panel Monitor Cable

Normally, use the USB cable as a connection cable for Touch Panel Monitor.

Use the RS-232C cable as a connection cable for Touch Panel Monitor in the following cases.

- When Touch Panel Monitor is taken apart 5 m or more from FH Sensor Controller.
- When the USB port of the FH Sensor Controller is used for other I/O connection and cannot be used for Touch Panel communications.

### ● Specification

Model	FH-VMDA (2m)	FH-VUAB (2m)	XW2Z-200PP-1 (2m)
Cable type	DVI-Analog Conversion Cable	USB Cable	RS-232C Cable
Vibration (resistance)	10 to 150 Hz, Single amplitude 0.1 mm, 10 times for 8 minutes for each three direction		
Ambient temperature range	Operating Condition: 0 to +50°C, Storage Condition: -10 to +60°C (with no icing or condensation)		
Ambient humidity range	Operating and Storage: 35 to 85% (with no condensation)		
Ambient atmosphere	No corrosive gases		
Material	Cable outer sheath, Connector: PVC		Cable outer sheath: PVC, Connector: ABS/Ni Plating
Minimum bending radius	36 mm	25 mm	59 mm
Weight	Approx. 220g	Approx. 75g	Approx. 162g

## Connection Example

### ● USB Connection (Cable Length Up to 5 m)

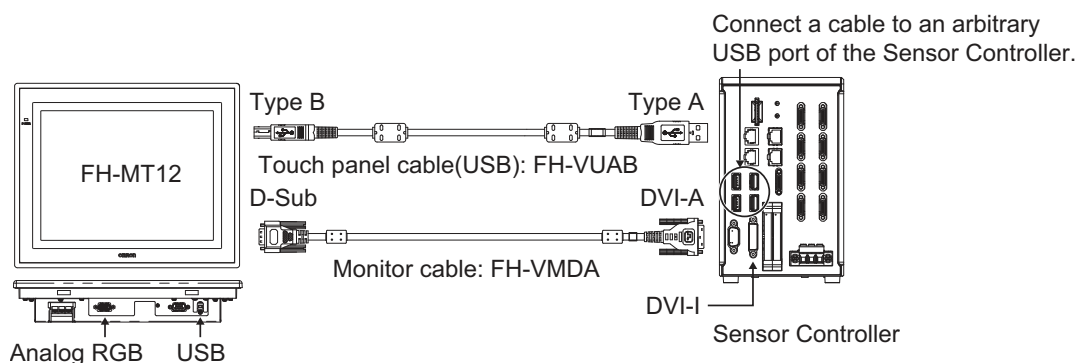

● **RS-232C Connection (Cable Length Up to 10 m)**

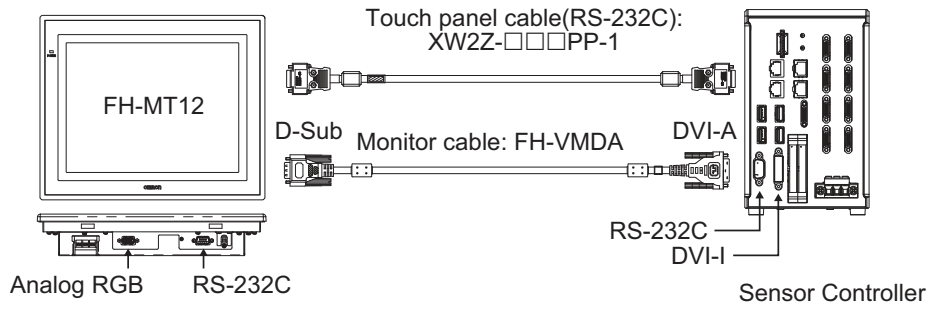

A video signal cable and an operation signal cable are required to connect the Touch Panel Monitor.

Signal	Cable	2 m	5 m	10 m
Video signal	DVI-Analog Conversion Cable	OK	OK	OK
Touch panel operation signal	USB Cable	OK	OK	-
	RS-232C Cable	OK	OK	OK

## Wiring

The power terminal block for the Touch Panel Monitor is located on the back of it. Connect a power supply of 24 VDC there.

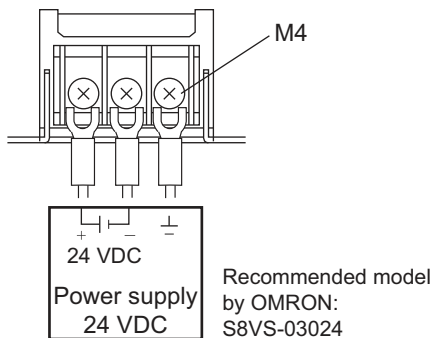

Indication on the power terminal block	Name	Function
+	DC input terminal (+V)	Connect to the DC output terminal (+V) of 24 VDC power.
-	DC input terminal (-V)	Connect to the DC output terminal (-V) of 24 VDC power.
	FG (Functional grounding terminal)	Connect to the earth. Functional grounding is done to protect device and system functions, including prevention of noise from external sources, or prevention of noise from devices or equipment that could have harmful effects on other devices or equipment

- Wire the power supply wires as short as possible. (Max.2 m)
  - If UL's certification is required, use a UL class II power supply.
  - Use the cables and crimping terminals with the specified dimensions.
- Do not directly connect an electric wire that is simply twisted to the terminal block.

- Recommended wire size: AWG 13 to 22 (0.326 to 2.62 mm<sup>2</sup>)
- Terminal screw: M4 (Tightening torque: 1.0 N•m)
- Crimping Terminal



## Dimensions

### ● Touch Panel Monitor

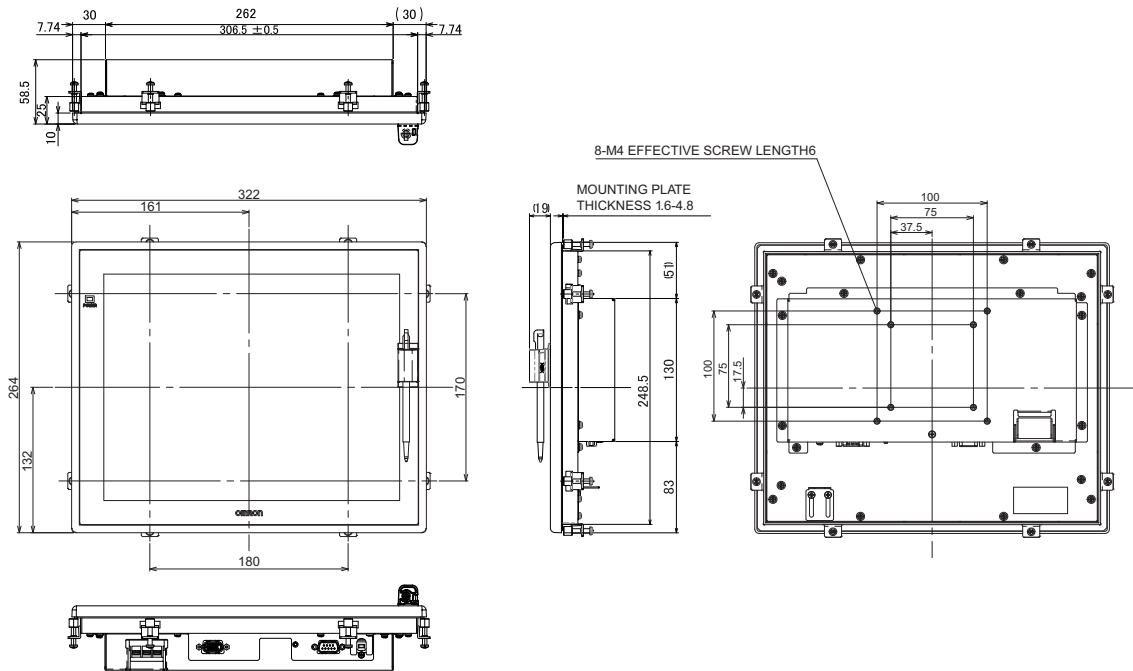

(Unit: mm)

Note:

1. Panel thickness: 1.6 to 4.8 mm
2. No burr allowed

### ● DVI-Analog Conversion Cable for Touch Panel Monitor: FH-VMDA

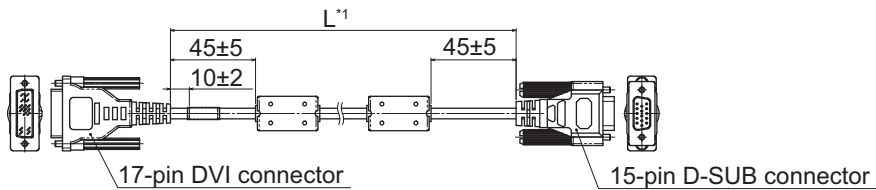

\*1. Cable is available in 2 m/5 m/10 m.

(Unit: mm)

### ● RS-232C Cable for Touch Panel Monitor: XW2Z-□□□PP-1

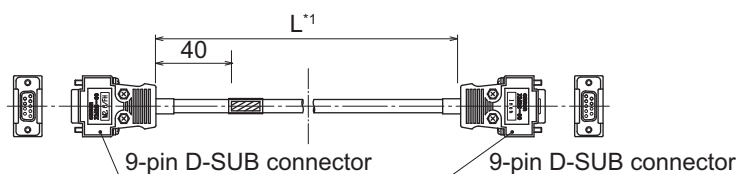

\*1. Cable is available in 2 m/5 m/10 m.

(Unit: mm)

● **USB Cable for Touch Panel Monitor: FH-VUAB**

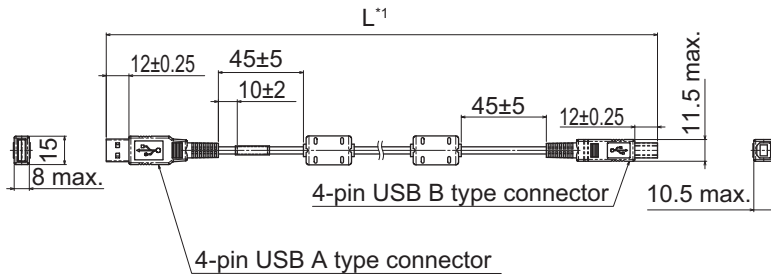

\*1. Cable is available in 2 m/5 m.

(Unit: mm)

## 3-5 LCD and Cable

### Specification

#### ● LCD Monitor

Model	FZ-M08
Size	8.4 inches
Type	Liquid crystal color TFT
Resolution	1,024 x 768 dots
Input signal	Analog RGB video input 1 channel
Supply Voltage	21.6 to 26.4 VDC
Current consumption	Approx. 0.7 A max.
Ambient temperature range	Operating: 0 to +50°C, Storage: -25 to +65°C (with no icing or condensation)
Ambient humidity range	Operating and Storage: 35 to 85% (with no condensation)
Weight	Approx. 1.2kg
Accessories	Instruction Sheet and 4 mounting brackets

#### ● LCD Monitor Cable

Model	FZ-VM
Vibration (resistance)	10 to 150 Hz, Single amplitude 0.15 mm, 3 directions, 8 strokes, 4 times
Ambient temperature range	Operation: 0 to +50°C, Storage: -20 to +65°C (with no icing or condensation)
Ambient humidity range	Operating and Storage: 35 to 85% (with no condensation)
Ambient atmosphere	No corrosive gases
Material	Cable sheath: heat-resistant PVC Connector: PVC
Minimum bending radius	75 mm
Weight	Approx. 170g



#### Precautions for Correct Use

Use the DVI-Analog Conversion Cable for Touch Panel Monitor: FH-VMDBA when connect the Sensor Controllers to the LCD monitor: FZ-M08. FZ-VM cable can use by combining the DVI-I - RGB Conversion Connector: FH-VMRGB.

## Component Names and Functions

### ● Front View

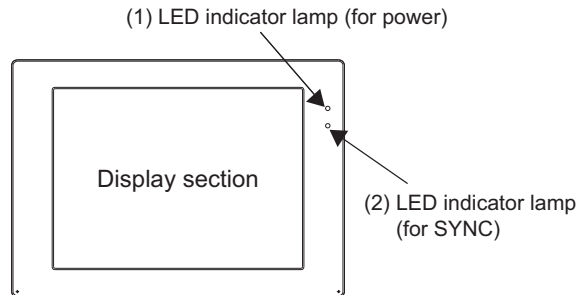

### ● Rear

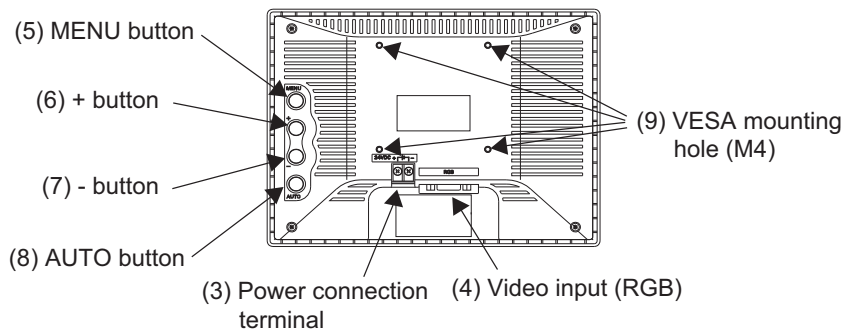

	Name	Description
(1)	LED indicator lamp (for power)	Lit up green when power is ON.
(2)	LED indicator lamp (for SYNC)	Lit up orange while the video signal is input.
(3)	Power supply terminal	Connect a 24 VDC power supply.
(4)	Video input (RGB)	Video input terminal (RGB)
(5)	MENU button	OSD operating button (MENU button)
(6)	+ button	OSD operating button (+ button)
(7)	- button	OSD operating button (- button)
(8)	AUTO button	OSD operating button (AUTO button)
(9)	VESA mounting hole (M4)	Mounting hole for VESA 75 mm x 75 mm.

## Wire

The power terminal block for the Touch Panel Monitor is located on the back of it. Connect a power supply of 24 VDC there.

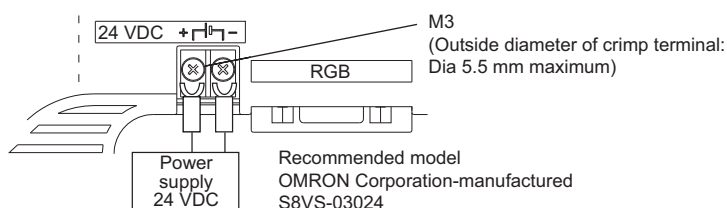

- Keep the power supply wires as short as possible (maximum 10 m).

- If UL recognition is required, use a UL class II power supply.
- Regarding installation, do not use the VESA mounting but fix the monitor unit using the board mounting.

## Dimensions

### ● LCD Monitor

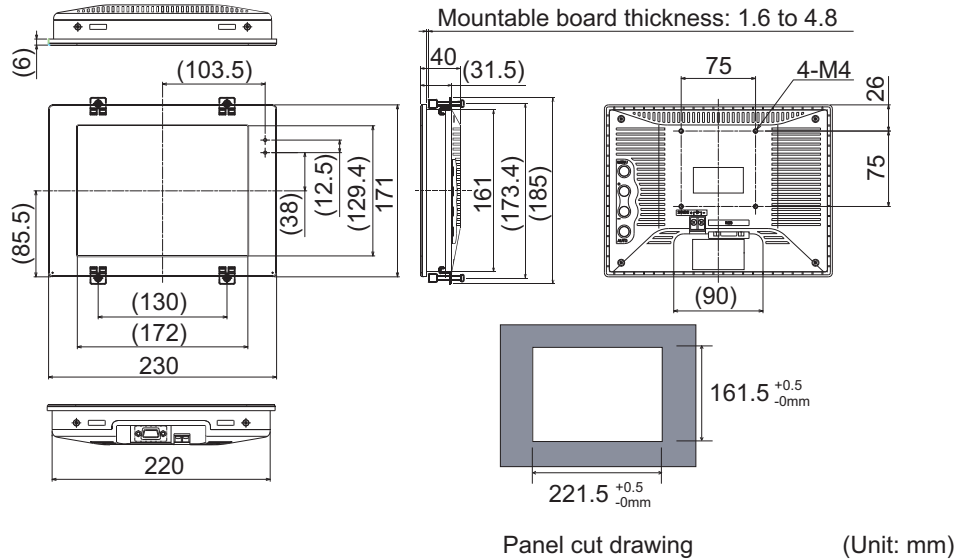

### ● Monitor Cable: FZ-VM

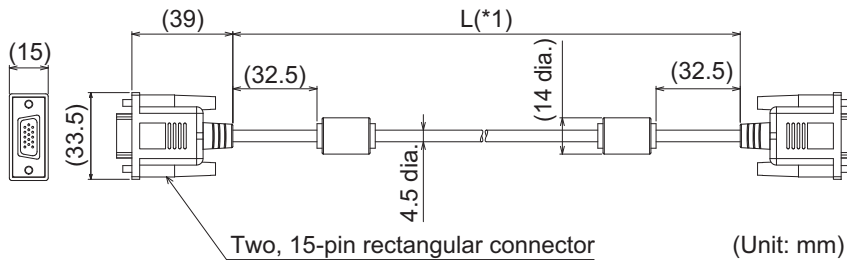

\*1. Cable is available in 2 m/5 m.

### ● DVI-I -RGB Conversion Connector: FH-VMRGB

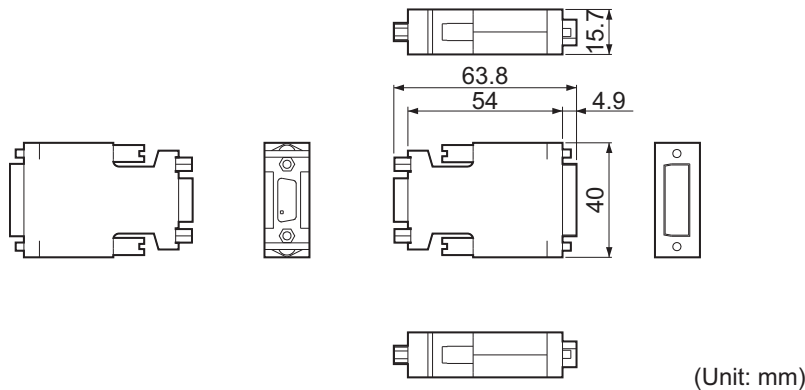





# 4

## Handling and Installation Environment

---

4-1	FH-5050 .....	4-2
-----	---------------	-----

## 4-1 FH-5050

### WARNING

This product must be used according to this manual and Instruction Sheet. Failure to observe this may result in the impairment of functions and performance of the product.



This product is not designed or rated for ensuring the safety of persons. Do not use it for such purposes.



A lithium battery is built into the Controller and may occasionally combust, explode, or burn if not treated properly. Dispose of the Controller as industrial waste, and never disassemble, apply pressure that would deform, heat to 100°C or higher, or incinerate the Controller.



#### Precautions for Safe Use

##### Installation Environment

- Do not use the product in the environment with flammable or explosive gases.
- Install the product so that the air can flow freely through its cooling vents.
- Regularly clean the vent holes or fan outlet to prevent dust or particles blocking them. Internal temperature increases when those are blocked, it causes malfunction.
- To secure safety for operation and maintenance, install the product apart from high-voltage devices and power devices.
- Make sure to tighten all screws in mounting.

##### Handling of Sensor Controller

- Do not attempt to dismantle, repair, or modify the product.
- Do not drop the product nor apply excessive vibration or shock to the product. Doing so may cause malfunction or burning.
- This product is heavy. Be careful not to drop it while handling.



## Precautions for Correct Use

### Installation and Storage Sites

Install and store the product in a location that meets the following conditions:

- Surrounding temperature of 0 to +45°C (-20 to +65°C in storage)  
Do not let the ambient temperature exceed 45°C (117°F).  
Provide a forced-air fan cooling or air conditioning if the ambient temperature is near 45°C (117°F) so that the ambient temperature never exceeds 45°C (117°F).
- Relative humidity of between 35 to 85%
- No rapid changes in temperature (place where dew does not form)
- No presence of corrosive or flammable gases
- Place free of dust, salts and iron particles
- Place free of vibration and shock
- Place out of direct sunlight
- Place where it will not come into contact with water, oils or chemicals
- Place not affected by strong electro-magnetic waves
- Place not near to high-voltage, or high-power equipment
- Do not install the product immediately above significant heat sources, such as heaters, transformers, or large-capacity resistors.

### Handling of Sensor Controller

- When touching a terminal part or a signal wire in a connector, take anti-static measures using a wrist strap or another device to prevent damage from static electricity.
- Handling a USB flash drive:  
Before removing a USB flash drive, make sure that data is not being read or written to them. For a USB flash drive, the memory device's LED flashes or lights while data is being read or written, so make sure that it is turned OFF before removing the memory.

### Maintenance

- Lightly wipe off dirt with a soft cloth.
- Do not use thinners or benzine.
- Clean the lens with a lens-cleaning cloth or air brush.
- Dirt on the image element must be removed using an air brush.

### Orientation of Product

- For good heat dissipation, install the product only in the position shown below so as not to block the ventilation holes. Install the product so that the air can flow freely through its cooling vents.



- Do not install the product in the following positions.

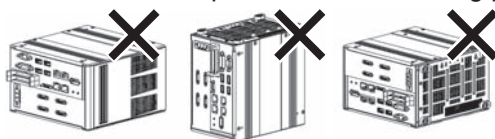

- For good ventilation, provide a clearance of 50 [mm] or more above the Sensor Controller away from other devices in the normal floor mounting. For the right and left sides, provide a clearance of 30 [mm] or more, and for the back side, 15 [mm] or more. These clearances are also required when mounting multiple Sensor Controllers side by side. For the back mounting, the back-side clearance of 15 [mm] is not required.

### Handling a SD memory card

- Before removing a SD memory card, make sure that data is not being read or written to them.
  - For SD memory card, the SD BUSY LED flashes or lights while data is being read or written, so make sure that it is turned OFF before removing the memory.
  - Do not insert an SD memory card in the reverse orientation, at an angle, or in a twisting manner.
-

# 5

## Setup and Wiring

---

<b>5-1</b>	<b>When turning ON and OFF .....</b>	<b>5-2</b>
5-1-1	FH-5050 .....	5-2
<b>5-2</b>	<b>Fail-Safe Measures.....</b>	<b>5-4</b>
<b>5-3</b>	<b>Sensor Controller Installation .....</b>	<b>5-5</b>
5-3-1	FH-5050 .....	5-5
<b>5-4</b>	<b>Setup Touch Panel Monitor or Monitor .....</b>	<b>5-10</b>
5-4-1	FH-5050 .....	5-10
<b>5-5</b>	<b>Camera Installation .....</b>	<b>5-11</b>
5-5-1	FH-5050 .....	5-11
5-5-2	Installation of 3D Vision Sensor .....	5-12
<b>5-6</b>	<b>Insert/Remove SD Memory Card or USB Flash Drive .....</b>	<b>5-17</b>
5-6-1	FH-5050 .....	5-17
<b>5-7</b>	<b>Use by Connecting Software .....</b>	<b>5-18</b>
5-7-1	Simulation Software .....	5-18
<b>5-8</b>	<b>Installation in a Control Panel.....</b>	<b>5-19</b>
5-8-1	FH-5050 .....	5-19

## 5-1 When turning ON and OFF

### 5-1-1 FH-5050

#### WARNING

Never connect the AC power supply with this product. When the AC power supply is connected, it causes the electric shock and a fire.



Do not touch the terminals while the power supply is ON. Doing so may result in electrical shock.



#### Caution

Please take fail-safe measures on your side in preparation for an abnormal signal due to signal conductor disconnection and/or momentary power interruption.  
An abnormal operation may result in a serious accident.



#### Precautions for Safe Use

- Check the following again before turning on the power.
  - Are the voltage and polarity of the power supply correct? (24 VDC)
  - Is the load of the output signal not short-circuited?
  - Is the load current for the output signal within the specified range?
  - Are there no wrong wirings?
  - Are the voltage value and polarity of the power supply that is provided to the encoder cable (ENC0 VDD/GND, ENC1 VDD/GND) correct? (5 VDC)
- While the power is ON or immediately after the power is turned OFF, the Sensor Controller and camera case are still hot. Do not touch the case.
- Make sure to turn off the power when attach or detach cameras or cables. Connecting cables while the power is supplied may cause malfunction or damage to cameras or peripheral devices.
- Illumination is normal immediately after the power supply is turned ON. Do not look directly into the illumination light.
- After confirming that the product is started up, communicate with the high-order device.
- Should you notice any abnormalities, immediately stop use, turn OFF the power supply, and contact your OMRON representative.



## Precautions for Correct Use

---

### Turning OFF the Power

When a message is displayed indicating that a task is in progress, do not turn OFF the power. Doing so causes the data in the memory to be corrupted, resulting in the product not operating properly upon the next start-up.

Do not turn OFF during saving data to Sensor Controller.

When turns OFF, conform the followings proceedings have completed. and then operate again.

- When saves using Sensor Controller: Confirm the save processing is completed and next operation is possible.
- When saves using communication command: Intended command is completed. BUSY signal is turned OFF.
- After turning off the power, wait at least 1 second before restarting.

### Maintenance

Turn OFF the power and ensure the safety before maintenance.

---

## 5-2 Fail-Safe Measures

The fail-safe measures are the same for each series. Confirm the following instructions.

### **WARNING**

Please take external safety measures so that the system as a whole should be on the safe side even if a failure of a Sensor Controller, a failure of a 3D Vision Sensor, or an error due to an external factor occurred. An abnormal operation may result in serious accident.



Please take fail-safe measures on your side in preparation for an abnormal signal due to signal conductor disconnection and/or momentary power interruption.



#### **Precautions for Safe Use**

- Be sure to take fail-safe measures externally when controlling stages and robots by using the measurement results of the Sensor Controller (axis movement output by calibration and alignment measurement).



#### **Precautions for Correct Use**

##### **Fail-Safe Measures**

- Be sure to take fail-safe measures externally when controlling stages and robots by using the measurement results of the Sensor Controller (axis movement output by calibration and alignment measurement).
- On a Sensor Controller side, supplementary use operations and branches of the Sensor Controller to configure a check flow such as “data should not be externally provide if the data is in a range from -XXXXX to XXXXX” based on the stage/robots range of movement.

##### **Communication with High-order Device**

- After confirming that the product is started up, communicate with the high-order device. During start-up, an indefinite signal may be output to the high-order interface. To avoid this problem, clear the receiving buffer of your device at initial operations.



## 5-3 Sensor Controller Installation

### 5-3-1 FH-5050



#### Precautions for Safe Use

##### Power Supply and Wiring

- Make sure to use the product with the power supply voltage specified by this manual.
- Provide the power from a DC power supply (safety extra-low voltage circuits) that has been taken measures not to generate high-voltage.
- Make sure to tighten all screws in mounting.
- Keep the power supply wires as short as possible (Max. 2 m).
- Use the wire of a suitable size (AWG 10 to 16) according to the current consumption.

##### Ground

- The power supply circuit of the FH Sensor Controller is insulated from the internal circuit.
- When a base is packed in a camera that will be connected to the Sensor Controller, make sure to mount the camera using the base. Since the enclosure of the camera body is connected to the internal circuits, the circuits may cause short-circuit with FG if the base is not used to mount the camera and result in malfunction or damage.
- Apply Class D grounding (grounding resistance: 100 [ $\Omega$ ] or less)
- Provide the grounding point as close to the product as possible to shorten the grounding wire.
- Wire the grounding wire for the Sensor Controller independently. If the grounding wire is shared with other devices or connected to a building beam, the Sensor Controller may be adversely affected.

##### Connect the FH Sensor Controller to FH-MT12

Do not ground the positive terminal of the 24 VDC power supply when connecting the Sensor Controller and FH-MT12 using a USB cable. The internal circuits may cause a short-circuit and result in malfunction.



#### Precautions for Correct Use

##### When connecting the sensor controller and monitor with a switcher and splitter

Do not use devices that may require re-recognition of the monitor by the Sensor Controller when a switching operation was performed. If such re-recognition processing happens at switching operation, it may cause measurement time to be longer.

## Connection of Terminal Block

Connecting of Sensor Controller's terminal block in order to connect package the terminal block connector (male; FH-XCN).

Use the specified wire size (AWG10 to 16) and keep the power supply wires as short as possible (Max. 2 m).

- 1 Insert the end of the signal line (electric wire) into the terminal block connector (male), and tighten the three screws on the connector top to fix the wire. Recommended tightening torque: 0.7-0.8 N•m

- 2** Connect the wire to the terminal block connector (male) depending on the indicated terminal block connector.

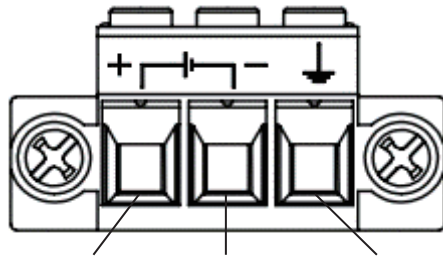

DC input terminal (+V) DC input terminal (-V) FG (functional grounding terminal)

Indicate of terminal block connector	Name	Function
+	DC input terminal (+V)	Connect to the DC output terminal (+V) of 24 VDC power.
-	DC input terminal (-V)	Connect to the DC output terminal (-V) of 24 VDC power.
	FG (Functional grounding terminal)	Connect to the earth. Functional grounding is done to protect device and system functions, including prevention of noise from external sources, or prevention of noise from devices or equipment that could have harmful effects on other devices or equipment

- When you ground the FG, it may cause to enter noise into devices or equipment. If an equipment malfunction or failure occurs, disconnect the FG from the ground and see if the condition improves.
- The outer shell of the Sensor Controller has continuity with the FG. Connecting the outer shell to the ground may allow noise to enter the device or equipment. If an equipment malfunction or failure occurs, remove the connection between the outer shell and the ground and see if the condition improves.
- For grounding, use a dedicated ground wire (2 mm<sup>2</sup> or larger) and apply Class D grounding (third class grounding: 100 Ω or less grounding resistance).
- Do not share the Sensor controller's ground with other equipment or ground the Sensor controller to the metal structure of a building. Doing so may worsen operation. Whenever possible, use an independent ground (with the ground pole separated by a minimum of 10 m from any other ground pole).
- Ground to 100 Ω or less, and if possible use a separate ground from those of other devices. (Refer to figure (a) in the diagram below.)
- If using an independent ground is not possible, then use a common ground as shown in figure (b). Connect to the ground pole of the other device.

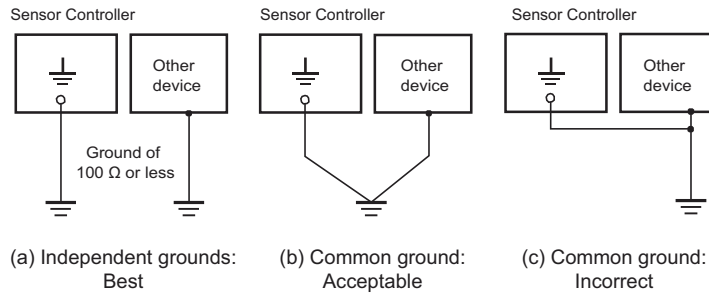

Grounding Methods

- 3** Insert the terminal block connector (male) to the terminal block connector (female) of Sensor Controller.
- 4** Tightens and fix the left and right screws for the terminal block connector (male). (Recommended tightening torque: 0.7 to 0.8 N•m)

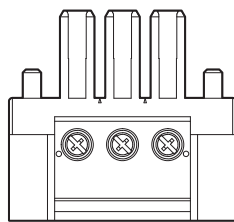
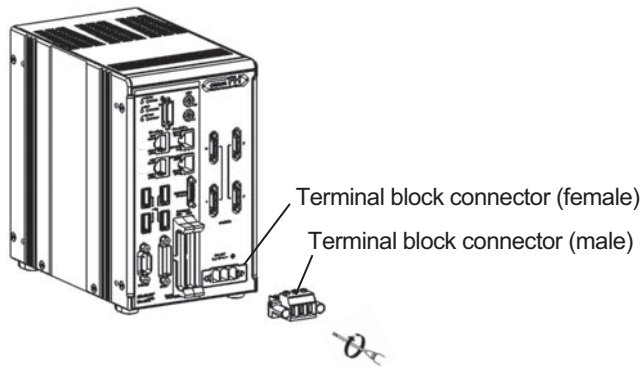

(Unit: mm)

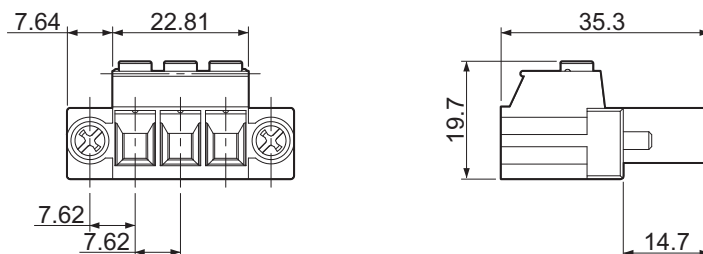

## Recommended Power Source of Sensor Controller

Power source types for FH series differ depending on the number of cameras due to current consumption differences. Refer to the following table to use the appropriate type.

When you connect your camera to the lighting via Light Controller, the current consumption is same as when the Intelligent Compact Digital camera is connected.

Item	Connected camera, Lighting controller, and Lighting type	FH-5050
Recommended Power Source S8VK-G S8VS	<ul style="list-style-type: none"> <li>• When connecting intelligent compact digital cameras:</li> <li>• When connecting the following lightings or light controllers without external power supplies:               <ul style="list-style-type: none"> <li>• FLV-TCC1</li> <li>• FLV-TCC4</li> <li>• FLV-TCC3HB</li> <li>• FLV-TCC1EP</li> <li>• FL-TCC1</li> </ul> </li> <li>• When connecting the following lighting or light controllers:               <ul style="list-style-type: none"> <li>• FL-TCC1PS</li> <li>• FL-MD□MC</li> </ul> </li> </ul>	S8VK-G24024 S8VS-18024
	Other than above case	S8VK-G12024 S8VS-12024

## Mounting of Sensor Controller

- Make sure to tighten all screws in mounting.
- For good ventilation, provide a clearance of 50 [mm] or more above the Sensor Controller away from other devices in the normal floor mounting. For the right and left sides, provide a clearance of 30 [mm] or more, and for the back side, 15 [mm] or more. These clearances are also required when mounting multiple Sensor Controllers side by side. For the back mounting, the back-side clearance of 15 [mm] is not required.
- Do not install the product immediately above significant heat sources, such as heaters, transformers, or large-capacity resistors.
- Do not install the Sensor Controller in a cabinet with high-voltage equipment installed.
- Mount the Sensor Controller at 200 [mm] or more from power cables apart.

● Side Mounting

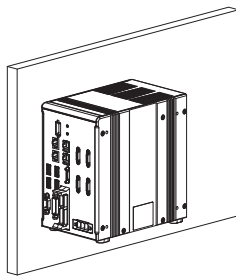

(Unit: mm)

• Left side

4-M4 depth 4.5 (mounting screw hole)

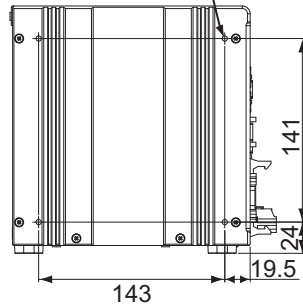

• Right side

4-M4 depth 4.5 (mounting screw hole)

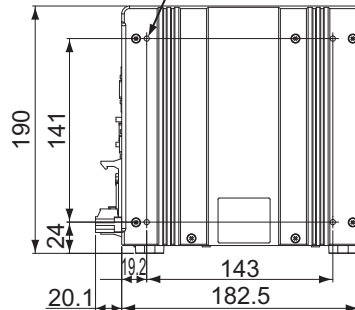

- \* Recommended tightening torque: 1.2 N•m to 1.3 N•m
- \* The tolerance is  $\pm 0.2$  mm.

● Bottom Mounting

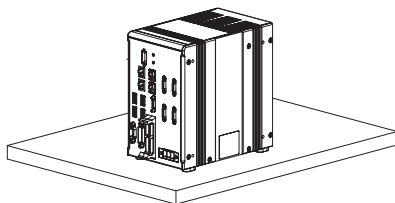

(Unit: mm)

• Bottom

4-M3 depth 4.5 (mounting screw hole)

Insulating leg: 4

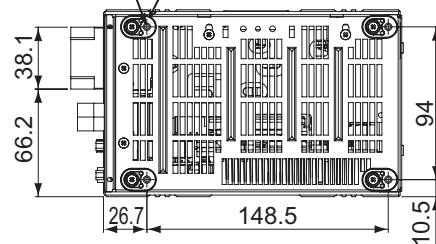

- \* Do not remove the Insulating leg. Fix the Insulating leg to secure the ventilation path.
- \* Recommended tightening torque: 0.54 N•m to 0.6 N•m
- \* The tolerance is  $\pm 0.2$  mm.

## 5-4 Setup Touch Panel Monitor or Monitor

---

Describes the notifications of Sensor Controller when you setup Touch Panel Monitor or Monitor. For handling or functions of monitor, refer to each of instruction sheet.

### 5-4-1 FH-5050



#### Precautions for Safe Use

---

- Use specialized cameras and cables for the product. If not, it may cause malfunction or damage.
  - Make sure to turn off the power when attach or detach cameras or cables. Connecting cables while the power is supplied may cause malfunction or damage to cameras or peripheral devices.
  - Do not apply torsion stress to cables. If not, it may cause damage to cables.
  - Secure the minimum bending radius of cables. If not, it may cause damage to cables.
  - DVI-I connector: Please insert the connector perpendicularly so that the connector resin part and pin are not rubbing against each other. Damaged pin may cause contact failure due to generation and invasion of resin powder.
  - Do not ground the positive terminal of the 24 VDC power supply when connecting the Sensor Controller and FH-MT12 using a USB cable. The internal circuits may cause a short-circuit and result in malfunction.
- 



#### Precautions for Correct Use

---

##### **When connecting the sensor controller and monitor with a switcher and splitter**

Do not use devices that may require re-recognition of the monitor by the Sensor Controller when a switching operation was performed. If such re-recognition processing happens at switching operation, it may cause measurement time to be longer.

##### **When fix the DVI connector**

If difficult to fix the bilateral screws of DVI connector, once loosen these. Then retry to fix, again.

---

## 5-5 Camera Installation

Guidelines and precautions for Sensor Controller installation when cameras are also installed.  
For handling and function information for specific cameras, refer to the appropriate instruction sheet.

### 5-5-1 FH-5050

#### **WARNING**

If you keep watching the LED light, it may have an adverse effect on the eyes, do not stare directly into the light emitted from the LED. If a specular object is used, take care not to allow reflected light to enter your eyes.



#### **Caution**



#### **Precautions for Safe Use**

- Use specialized cameras and cables for the product. If not, it may cause malfunction or damage.
- Make sure to turn off the power when attach or detach cameras or cables. Connecting cables while the power is supplied may cause malfunction or damage to cameras or peripheral devices.
- Since cables to which bending is frequently applied is easily broken, use the robotic cable type (bending resistant cable) to prevent damages.
- Do not apply torsion stress to cables. If not, it may cause damage to cables.
- Secure the minimum bending radius of cables. If not, it may cause damage to cables.
- While the power is ON or immediately after the power is turned OFF, the Sensor Controller and camera case are still hot. Do not touch the case.
- Do not ground the positive terminal of the 24 VDC power supply.



#### **Precautions for Correct Use**

##### **Maintenance**

- Turn OFF the power and ensure the safety before maintenance.
- Clean the lens with a lens-cleaning cloth or air brush.
- Lightly wipe off dirt with a soft cloth.
- Dirt on the image element must be removed using an air brush.
- Do not use thinners or benzine.
- When installing / replacing the camera, reset the parameter settings of the corresponding Camera Image Input processing item.

## 5-5-2 Installation of 3D Vision Sensor

### Mounting

Attach the camera to the 6th axis of the 6-axis articulated robot using a jig. Securely secure the camera in four places using M4 screws. (Tightening torque: 1.2 N•m)

- Example:

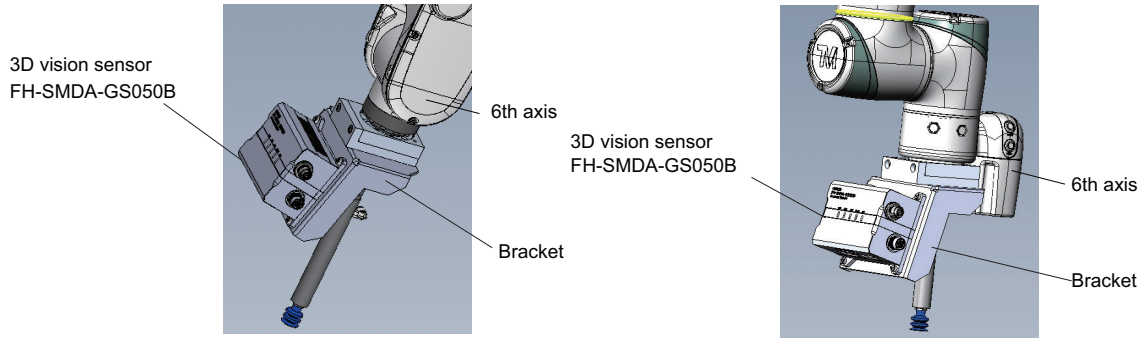

- Mounting dimensions(Unit: mm)

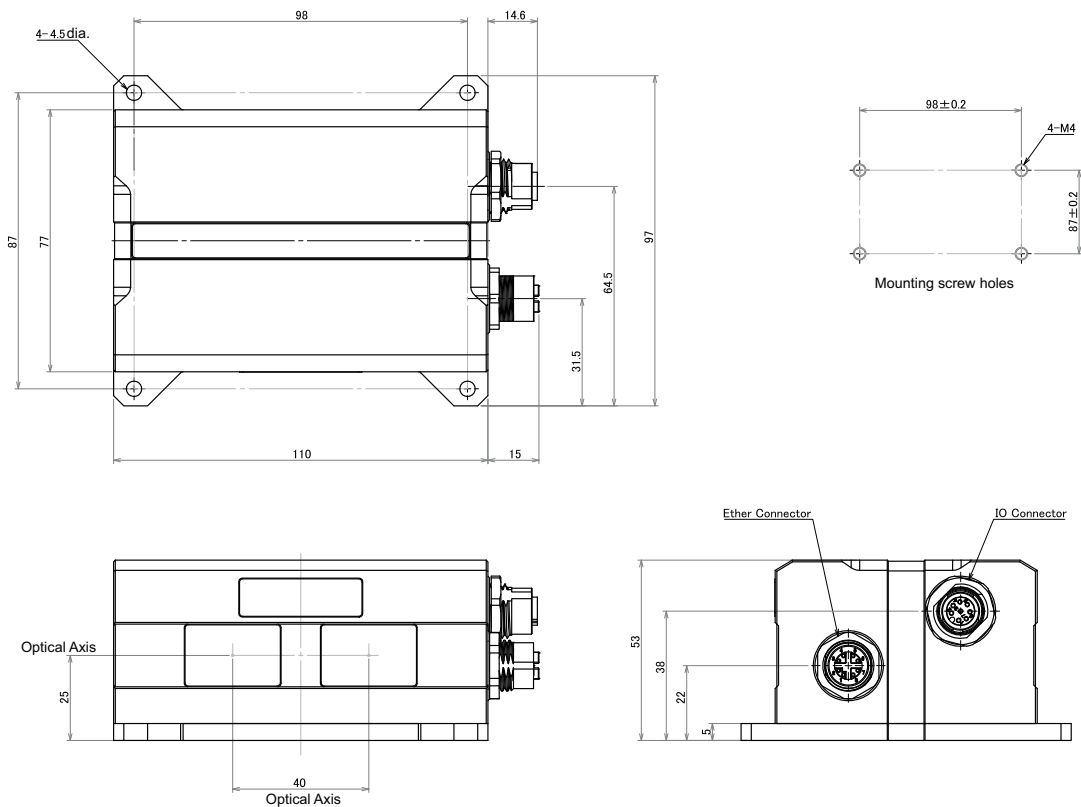



## Connecting

Connect the camera cable (Ethernet cable FHV-VNBX2 / FHV-VNLBX2 / FHV-VNBX / FHV-VNLBX: sold separately) to the Ethernet connector on the 3D vision sensor. Then connect it to the top of the two Ethernet connectors on the sensor controller.

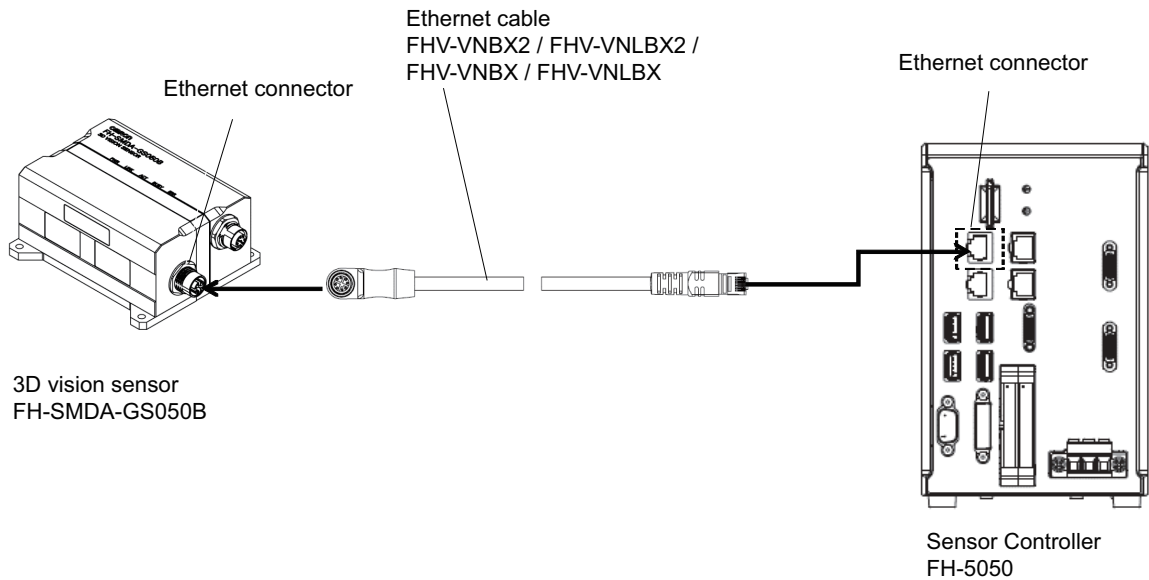

## Wiring

Wire the signal line of the camera I/O cable (FH-VSDX-BX / FH-VSDX-LBX: sold separately) with a crimp terminal. Insulate unnecessary signal lines and avoid contact with other signal lines.

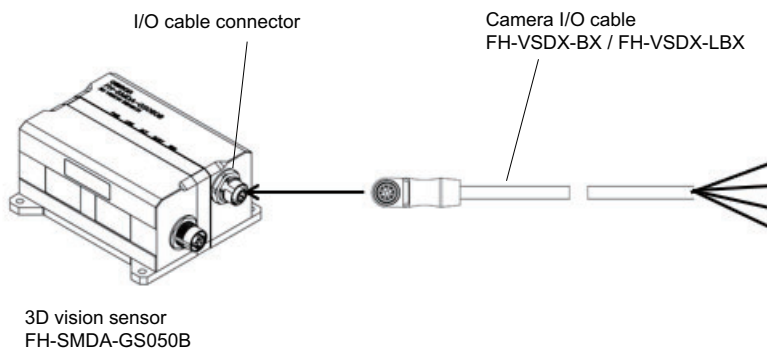

### Wire color of camera I/O cable

Signal name	Wire color
24VDC (For camera power supply)	Brown
0V (For camera power supply)	Blue
Unused*1	Yellow
Unused*1	Black
Unused*1	Red
Unused*1	Orange
NC	Gray

Signal name	Wire color
FG	Green
FG	Black (thick line)

\*1. Avoid contact with other power lines, ground lines, and signal lines.

## Camera cable mounting



### Precautions for Safe Use

- To prevent the cables from being caught in the rotating robot, connect them with a sufficient clearance, taking into account the minimum bending radius.
- To prevent the connectors from interfering with the robot, adjust the rotation angle of the robot.

(Unit: mm)

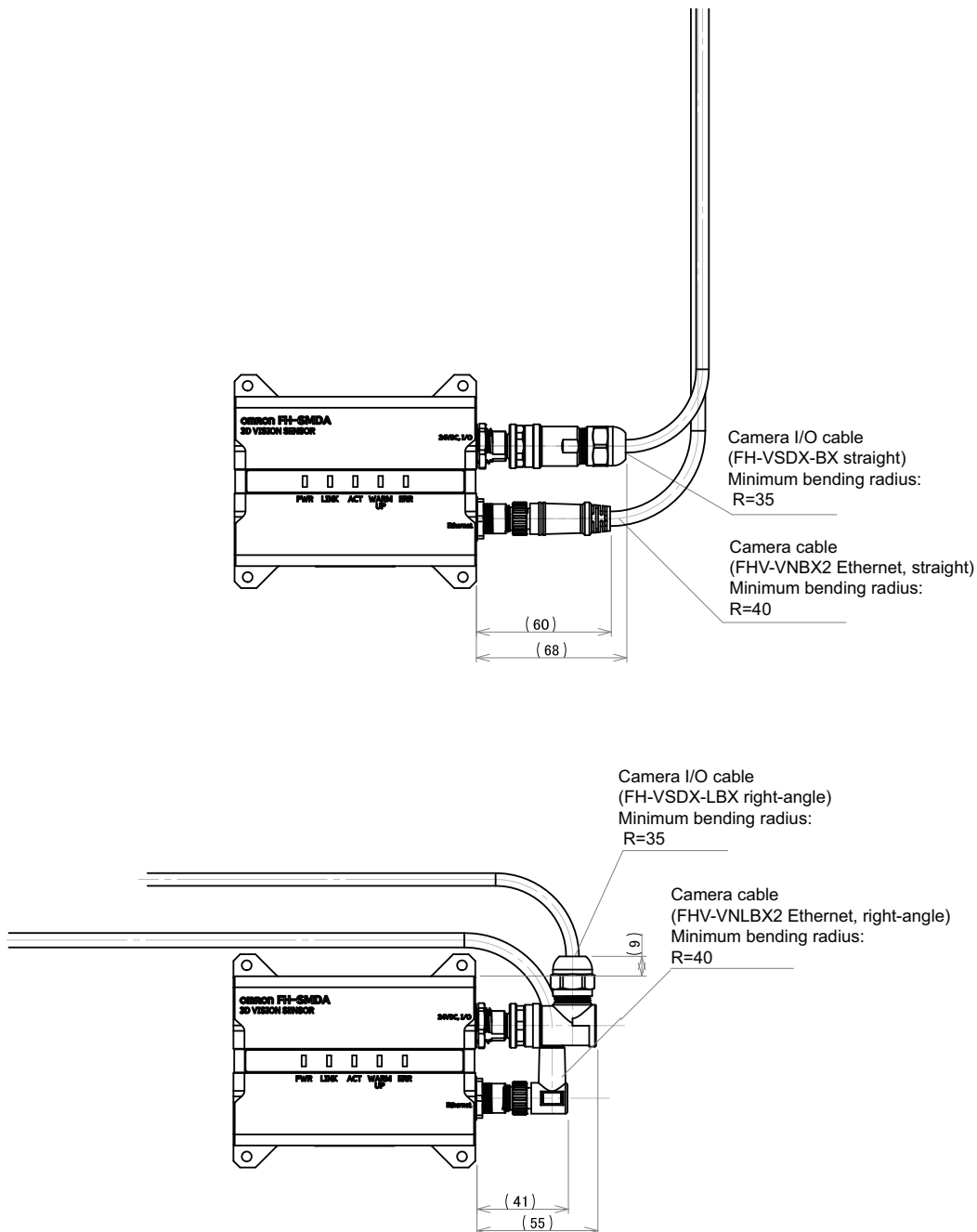

(Unit: mm)

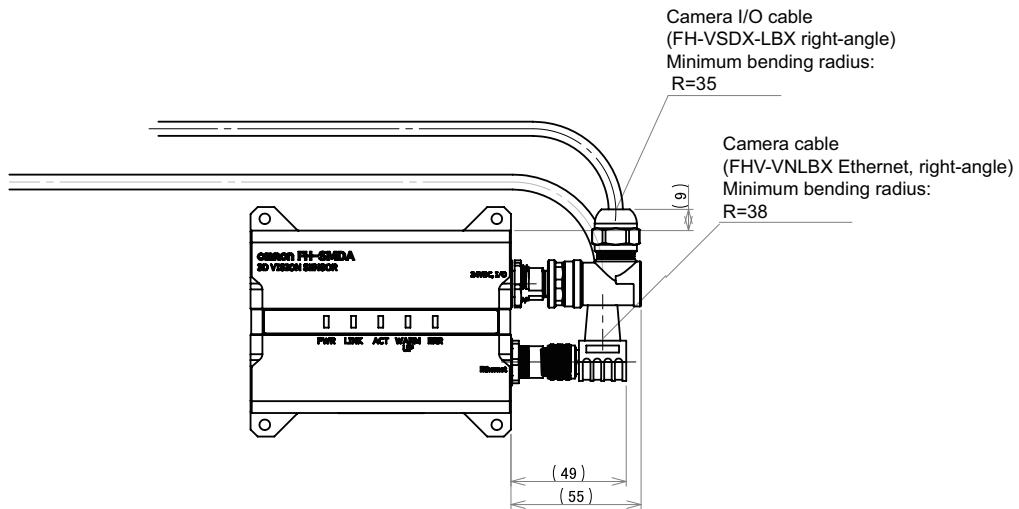
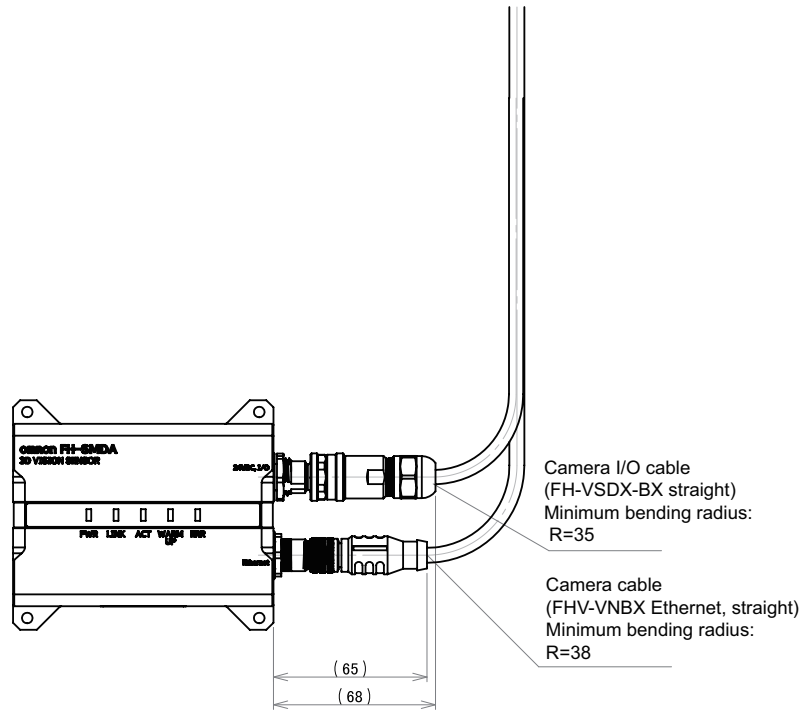

## 5-6 Insert/Remove SD Memory Card or USB Flash Drive

### 5-6-1 FH-5050



#### Precautions for Correct Use

---

##### When removing USB flash drive

- Before removing a USB flash drive, make sure that data is not being read or written to them.
  - For a USB flash drive, the memory device's LED flashes or lights while data is being read or written, so make sure that it is turned OFF before removing the memory.
  - When a message is displayed indicating that a task is in progress, do not turn OFF the power. Doing so causes the data in the memory to be corrupted, resulting in the product not operating properly upon the next start-up.
- 

Do not insert or remove USB flash drive during measurement, loading, and writing. There is the possibility of measurement time or damage of data.



#### Precautions for Correct Use

---

##### Handling of SD memory card

- When you touch a terminal part of SD memory card, antistatic is required by using a wrist strap or others.
- Do not insert an SD memory card in the reverse orientation, at an angle, or in a twisting manner.

##### Removing SD memory card

- Before removing a SD memory card, make sure that data is not being read or written to them.
  - For SD memory card, the SD BUSY LED flashes or lights while data is being read or written, so make sure that it is turned OFF before removing the memory.
  - When a message is displayed indicating that a task is in progress, do not turn OFF the power. Doing so causes the data in the memory to be corrupted, resulting in the product not operating properly upon the next start-up.
- 

Do not insert or remove SD memory card during measurement, loading, and writing. There is the possibility of measurement time or damage of data.



#### Additional Information

---

For external storage device and external drive name, refer to the *Using External Storage Devices and External Drive Name* in the Vision System FH/FHV Series User's Manual (Cat. No. Z365).

---

## 5-7 Use by Connecting Software

---

Simulation Software is dedicated software.

### 5-7-1 Simulation Software

Using the Simulation Software, you can check the operation or functions of Vision System FH series on a PC.

When you purchase these series newly, both software CD-ROM and license are required.



#### **Additional Information**

---

For using the Simulation Software, refer to the description of *How To Use Simulation Software*.

---

## 5-8 Installation in a Control Panel

---

When the Sensor Controller is being installed in a cabinet or control panel, be sure to provide proper ambient conditions as well as access for operation and maintenance.

### 5-8-1 FH-5050



#### Precautions for Safe Use

---

##### Installation Environment

- Do not use the product in the environment with flammable or explosive gases.
- Install the product so that the air can flow freely through its cooling vents.
- Regularly clean the vent holes or fan outlet to prevent dust or particles blocking them. Internal temperature increases when those are blocked, it causes malfunction.
- To secure safety for operation and maintenance, install the product apart from high-voltage devices and power devices.
- Make sure to tighten all screws in mounting.

##### Accessibility for Operation and Maintenance

- Do not apply torsion stress to cables. If not, it may cause damage to cables.
  - Secure the minimum bending radius of cables. If not, it may cause damage to cables.
- 



#### Precautions for Correct Use

---

##### Installation and Storage Sites

Install and store the product in a location that meets the following conditions:

- No rapid changes in temperature (place where dew does not form)
- No presence of corrosive or flammable gases
- Place free of dust, salts and iron particles
- Place free of vibration and shock
- Place out of direct sunlight
- Place where it will not come into contact with water, oils or chemicals
- Place not affected by strong electro-magnetic waves
- Place not near to high-voltage, or high-power equipment

##### Ambient Temperature

- Do not install the product immediately above significant heat sources, such as heaters, transformers, or large-capacity resistors.
-



## Precautions for Correct Use

### Ambient Temperature

- Install and store the product in a location that meets the following conditions:
  - Surrounding temperature of 0 to +45°C (-20 to +65°C in storage)
  - Relative humidity of between 35 to 85%
- Do not let the ambient temperature exceed 45°C (117°F).
- Provide a forced-air fan cooling or air conditioning if the ambient temperature is near 45°C (117°F) so that the ambient temperature never exceeds 45°C (117° F).

### Orientation of Product

- For good heat dissipation, install the product only in the position shown below so as not to block the ventilation holes. Install the product so that the air can flow freely through its cooling vents.

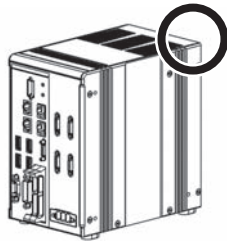

- Do not install the product in the following positions.



- For good ventilation, provide a clearance of 50 [mm] or more above the Sensor Controller away from other devices in the normal floor mounting. For the right and left sides, provide a clearance of 30 [mm] or more, and for the back side, 15 [mm] or more. These clearances are also required when mounting multiple Sensor Controllers side by side. For the back mounting, the back-side clearance of 15 [mm] is not required.

## Ambient temperature and humidity

- Panels have been reduced in size due to space-saving and miniaturization in devices and systems, and the temperature inside the panel may be at least 10 to 15°C higher than outside the panel. Implement the following measures against overheating at the installation site and in the panel, and allow a sufficient margin for the temperature.
- The Controller may not start normally if the temperature is below 0°C when the power is turned ON. Maintain an air temperature of at least approximately 5°C inside the panel, by implementing measures such as installing a low-capacity space heater in the panel. Alternatively, leave the Controller power ON to keep the Controller warm.
- Rapid temperature changes can cause condensation to occur, resulting in malfunctioning due to short-circuiting. When there is a possibility of this occurring, take measures against condensation, such as leaving the Controller power ON at night or installing a heater in the control panel to keep it warmer.

## Vibration and Shock

The Controller is tested for conformity with the sine wave vibration test method (IEC 60068-2-6) and the shock test method (IEC 60068-2-27) of the Environmental Testing for Electrotechnical Products. It



is designed so that malfunctioning will not occur within the specifications for vibration and shock. If, however, the Controller is to be used in a location in which it will be directly subjected to regular vibration or shock, then implement the following countermeasures:

- Separate the control panel from the source of the vibration or shock. Or secure the Controller and the panel with rubber padding to prevent vibration.
- Make the building or the floor vibration-resistant.
- To prevent shock when other devices in the panel such as electromagnetic contactors operate, secure either the source of the shock or the Controller with rubber padding.

## Accessibility for Operation and Maintenance

---

- To ensure safe access for operation and maintenance, separate the Controller as much as possible from high-voltage equipment and power machinery.
- Secure the minimum bending radius of the cable. Otherwise the cable may be damaged.
- Consider the physical size of USB flash drive, or SD memory card as these will be inserted in to the mounted Sensor Controller.



# 6

## I/O Interface

---

<b>6-1</b>	<b>Parallel Interface .....</b>	<b>6-2</b>
6-1-1	FH-5050 .....	6-2
<b>6-2</b>	<b>EtherCAT Interface .....</b>	<b>6-11</b>
6-2-1	FH-5050 .....	6-11
<b>6-3</b>	<b>Ethernet Interface .....</b>	<b>6-13</b>
6-3-1	FH-5050 .....	6-13

# 6-1 Parallel Interface

Parallel interfaces vary by Sensor Controller series. Refer to the appropriate series for information.

## 6-1-1 FH-5050



### Precautions for Safe Use

- Use only the cables designed specifically for the product. Use of other products may result in malfunction or damage of the product.
- Always turn OFF the power of the FH-L series Sensor Controller and peripheral devices before connecting or disconnecting a camera or cable. Connecting the cable with power supplied may result in damage of the camera or peripheral devices.
- Since cables to which bending is frequently applied is easily broken, use the robotic cable type (bending resistant cable) to prevent damages.
- Do not apply torsion stress to cables. If not, it may cause damage to cables.
- Secure the minimum bending radius of cables. If not, it may cause damage to cables.



### Precautions for Correct Use

- Check the following items on the communications cables that are used in the network.
  - Are there any breaks?
  - Are there any shorts?
  - Are there any connector problems?
- When you connect the cable to the communications connectors on devices, firmly insert the communications cable connector until it locks in place.
- Do not lay the communications cables together with high-voltage lines.
- Do not lay the communications cable near devices that generate noise.
- Do not lay the communications cables in locations subject to high temperatures or high humidity.
- Do not lay the communications cables in locations subject to excessive dirt and dust or to oil mist or other contaminants.

The parallel interface can be used for both NPN and PNP. An appropriate wiring is required according on the external device.

The encoder interface, open collector type, is also included.

The encoder interface, open collector type, is ENCTRIG\_A, ENCTRIG\_B, ENCTRIG\_Z. Connect the corresponding pins to the encoder properly.

## Interface Specification

- Specifications vary depending on the pin's role.
- The pins for the encoder interface, open collector type, are ENCTRIG\_A (No. 8 and 11), ENCTRIG\_B (No. 12 and 13), ENCTRIG\_Z (No. 4 and 5). The response frequency of the encoder is 4 [KHz].

### ● [Input]

Object signals:

- No.14 pin: Use the COMIN1 terminal when using these signals.
- No.37 to 46 pins: Use the COMIN2 terminal when using these signals.

Item	Specifications
Input voltage	12 to 24 VDC $\pm$ 10 %
ON current*1	5 mA min.
ON voltage*1	8.8 V min.
OFF current*2	0.5 mA max.
OFF voltage*2	1.1 V max.
ON delay	5 ms max.
OFF delay	0.7 ms max.

\*1. ON current and ON voltage:

These are the current value or voltage value to turn ON from OFF. The value for the ON voltage is the potential difference between COMIN and each input terminal.

\*2. OFF current and OFF voltage:

These are the current value or voltage value to turn OFF from ON. The value for the OFF voltage is the potential difference between COMIN and each input terminal.

## ● [Input]

Object signals:

- No.4 to 6, 9 to 11 pins: Use the COMIN1 terminal when using these signals.
- No.7, 8, 12, 13 pins: Use the COMIN0 terminal when using these signals.

Item	Specifications
Input voltage	12 to 24 VDC $\pm$ 10 %
ON current*1	5 mA min.
ON voltage*1	8.8 V min.
OFF current*2	0.5 mA max.
OFF voltage*2	0.8 V max.
ON delay	0.1 ms max.
OFF delay	0.1 ms max.
Max. response frequency	4 KHz

\*1. ON current and ON voltage:

These are the current value or voltage value to turn ON from OFF. The value for the ON voltage is the potential difference between COMIN and each input terminal.

\*2. OFF current and OFF voltage:

These are the current value or voltage value to turn OFF from ON. The value for the OFF voltage is the potential difference between COMIN and each input terminal.

## ● [Output]

Object signals:

- No.15 to 19 pins, No.28 to 32 pins: Use the COMOUT0 terminal when using these signals.
- No.48 to 57 pins: Use the COMOUT2 terminal when using these signals.
- No.58 to 66 pins: Use the COMOUT3 terminal when using these signals.

Item	Specifications
Output voltage	12 to 24 VDC $\pm$ 10 %
Load current*1	45 mA max.
ON residual voltage	2 V max.

Item	Specifications
OFF leakage current	0.2 mA max.

\*1. The load current must be the specified current value or lower. Exceeding the specified current value may cause damage to the output circuit.

## ● [Output]

Object signals:

- No.20 to 27 pins: Connect the COMOUT1 and COMIN0 terminals when using these signals.

Item	Specifications
Output voltage	12 to 24 VDC $\pm$ 10 %
Load current*1	45 mA max.
ON residual voltage	2 V max.
OFF leakage current	0.2 mA max.

\*1. The load current must be the specified current value or lower. Exceeding the specified current value may cause damage to the output circuit.

## ● Connection

Connect the parallel I/O cable with more than the minimum bending radius.

## ● Pin Assignment

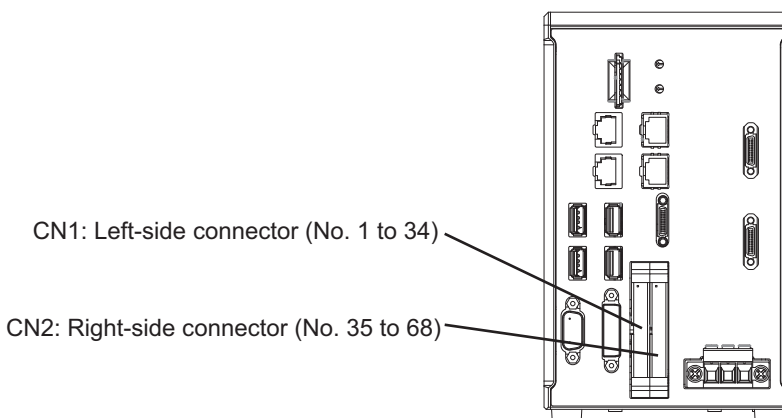

## Cable, I/O connector and Terminal Block

Use the following parallel I/O cable.

Name	Model	Description	Remark
Parallel I/O cable	XW2Z-S013-□	Specialized for FH series Cable length: 2 m, 5 m Min. bending radius: 10 mm	<ul style="list-style-type: none"> <li>• Two these cables are needed to use all I/O signals.</li> <li>• One side of this cable is flat cable and another side of it is a connector.</li> <li>• Connect the parallel I/O cable with securing the minimum bending radius and more.</li> <li>• Cable length is set to □ in the model number. (2 = 2 m, 5 = 5 m)</li> </ul>

Name	Model	Description	Remark
Parallel I/O cable for Connector-Terminal Conversion Unit	XW2Z-□□ □EE	Specialized for FH series Cable length: 0.5 m, 1 m, 1.5 m, 2 m, 3 m, 5 m Min. bending radius: 83.2 mm	<ul style="list-style-type: none"> <li>Two these cables are needed to use all I/O signals.</li> <li>One side of this cable is flat cable and another side of it is a connector.</li> <li>Connect the parallel I/O cable with securing the minimum bending radius and more.</li> <li>Cable length is set to □ in the model number. (050 = 0.5 m, 100 = 1 m, 150 = 1.5 m, 2 = 2 m, 300 = 3 m, 500 = 5 m)</li> <li>Connectable Connector-Terminal Block Conversion Unit: XW2R-□34GD-T</li> </ul>
Connector-Terminal Conversion Unit for general-purpose	XW2R-□34GD-T	-	The following is set to □ in the model number. For details, refer to the <i>XW2R Series catalog (Cat. No. G077)</i> .

### ● XW2Z-S013-□

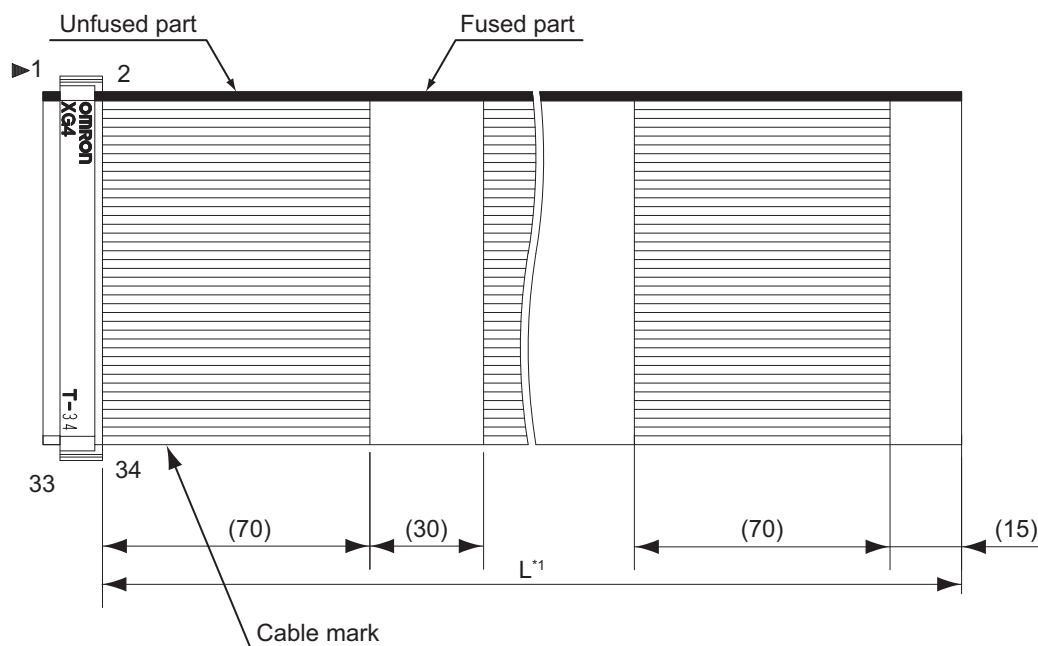

\*1. Cable is available in 2 m/5 m.

## Pin Layout

Terminal assignments and signal names should be set according to the FH Sensor Controller's operation mode settings. Verify that the wiring conforms to that.



### Precautions for Correct Use

The following terminals are not supported by 3D robot vision.

- STEP0/ENCTRIG\_Z0
- ENCTRIG\_A0
- ENCTRIG\_B0
- READY0
- STGOUT0/SHTOUT0
- STGOUT1-7



### Additional Information

For Operation Mode, refer to the *Setting the Operation Mode* in the *Vision Sensor FH/FHV Series User's Manual (Cat. No. Z365)*.

No.	I/O	XW2Z-S013-□ Wire color	XW2R-□34GD-T Con- nector-Terminal Block Conversion Units, Gen- eral-purpose devices	Signal name
				1-line mode
CN1				
1	-	Red	A1	COMIN0
2	-	Gray	B1	COMIN1
3	-	Gray	A2	Vacant
4	IN	Gray	B2	STEP0/ENCTRIG_Z0*1
5	IN	Green	A3	Not used*3
6	IN	Gray	B3	Not used*3
7	IN	Gray	A4	Not used*3
8	IN	Gray	B4	ENCTRIG_A0*1
9	IN	Gray	A5	Not used*3
10	IN	Green	B5	Not used*3
11	IN	Gray	A6	Not used*3
12	IN	Gray	B6	Not used*3
13	IN	Gray	A7	ENCTRIG_B0*1
14	IN	Gray	B7	Not used*3
15	OUT	Green	A8	RUN0
16	OUT	Gray	B8	READY0
17	OUT	Gray	A9	BUSY0
18	OUT	Gray	B9	OR0
19	OUT	Gray	A10	ERROR0
20	OUT	Green	B10	STGOUT0*4/SHTOUT0
21	OUT	Gray	A11	STGOUT1*4/SHTOUT1
22	OUT	Gray	B11	STGOUT2*4/SHTOUT2
23	OUT	Gray	A12	STGOUT3*4/SHTOUT3
24	OUT	Gray	B12	STGOUT4*4/SHTOUT4
25	OUT	Green	A13	STGOUT5*4/SHTOUT5
26	OUT	Gray	B13	STGOUT6*4/SHTOUT6
27	OUT	Gray	A14	STGOUT7*4/SHTOUT7



No.	I/O	XW2Z-S013-□ Wire color	XW2R-□34GD-T Con- nector-Terminal Block Conversion Units, Gen- eral-purpose devices	Signal name
				1-line mode
28	OUT	Gray	B14	Not used*3
29	OUT	Gray	A15	Not used*3
30	OUT	Green	B15	Not used*3
31	OUT	Gray	A16	Not used*3
32	OUT	Gray	B16	Not used*3
33	-	Gray	A17	COMOUT0
34	-	Gray	B17	COMOUT1
CN2				
35	-	Red	A1	COMIN2
36	-	Gray	B1	Vacant
37	IN	Gray	A2	DSA0
38	IN	Gray	B2	Not used*3
39	IN	Green	A3	DI0
40	IN	Gray	B3	DI1
41	IN	Gray	A4	DI2
42	IN	Gray	B4	DI3
43	IN	Gray	A5	DI4
44	IN	Green	B5	DI5
45	IN	Gray	A6	DI6
46	IN	Gray	B6	DI7
47	IN	Gray	A7	Vacant
48	OUT	Gray	B7	ACK
49	OUT	Green	A8	GATE0
50	OUT	Gray	B8	Not used*3
51	OUT	Gray	A9	DO0
52	OUT	Gray	B9	DO1
53	OUT	Gray	A10	DO2
54	OUT	Green	B10	DO3
55	OUT	Gray	A11	DO4
56	OUT	Gray	B11	DO5
57	OUT	Gray	A12	DO6
58	OUT	Gray	B12	DO7
59	OUT	Green	A13	DO8
60	OUT	Gray	B13	DO9
61	OUT	Gray	A14	DO10
62	OUT	Gray	B14	DO11
63	OUT	Gray	A15	DO12
64	OUT	Green	B15	DO13
65	OUT	Gray	A16	DO14
66	OUT	Gray	B16	DO15
67	-	Gray	A17	COMOUT2
68	-	Gray	B17	COMOUT3

Remarks:

COMIN0 to 2: Common for input signals, COMOUT0 to 3: Common for output signals,  
 DI0 to 7: Command inputs, DILINE0 to 2: Command inputs (Line specified) ,  
 ENCTRIG\_A0 to 1: Encoder trigger input for phase A, ENCTRIG\_B0 to 1: Encoder trigger input for phase B,  
 ENCTRIG\_Z0 to 1: Encoder trigger input for phase Z, STEP0 to 7: Measurement trigger,  
 ACK: Instruction execution complete flag, BUSY0 to 7: ON during processing,  
 DO0 to 15: Data outputs, ERROR: ON when an error occurs\*5,  
 ERROR0 to 3: ON when an error occurs, GATE0 to 1: ON during set output time,  
 OR0 to 7: Overall judgment results, READY0 to 7: ON when image input is permitted,  
 RUN0 to 3: ON when switched to output specified layout,  
 SHTOUT0 to 7: Shutter output signals, STGOUT0 to 7: Strobe trigger signals\*4

- \*1. Use the STEP signal when using measurement trigger inputs. Use the ENCTRIG\_A0/B0/Z0 when using encoder inputs
- \*2. When using one measurement trigger and one encoder input in the 2-line random mode, use ENCTRIG\_A0/B0/Z0 and STEP1.
- \*3. Do not connect anything for "Not used".
- \*4. This signal is used when the strobe signal is used for the Sensor Controller.
- \*5. The ERROR signal is shared among No.1 to 8 line.

## Internal Specifications for Parallel Interface

The parallel interface can be used for both NPN and PNP. Connect the pins properly according to the specifications of external devices.

### ● [Input]

Object signals:

- No.14 pin: Use the COMIN1 terminal when using these signals.
- No.37 to 46 pins: Use the COMIN2 terminal when using these signals.

a) Internal specifications for NPN connection

Item	Specifications
Internal circuit diagram	<p>Each input terminal</p>

b) Internal specifications for PNP connection

Item	Specifications
Internal circuit diagram	<p>Each input terminal</p>

### ● [Input]

Object signals:

- No.4 to 6, 9 to 11 pins: Use the COMIN1 terminal when using these signals.
- No.7, 8, 12, 13 pins: Use the COMIN0 terminal when using these signals.

## a) Internal specifications for NPN connection

Item	Specifications
Internal circuit diagram	<p>Each input terminal</p>

## b) Internal specifications for PNP connection

Item	Specifications
Internal circuit diagram	<p>Each input terminal</p>

## ● [Output]

Object signals:

- No.15 to 19 pin, No.28 to 32pin: Use the COMOUT0 terminal when using these signals.
- No.48 to 57 pins: Use the COMOUT2 terminal when using these signals.
- No.58 to 66 pins: Use the COMOUT3 terminal when using these signals.

## a) Internal specifications for NPN connection

Item	Specifications
Internal circuit diagram	<p>Each output terminal</p>

## b) Internal specifications for PNP connection

Item	Specifications
Internal circuit diagram	<p>Each output terminal</p>

## ● [Output]

Object signals:

- No.20 to 27 pins: Connect the COMOUT1 and COMIN0 terminals when using these signals.

## a) Internal specifications for NPN connection

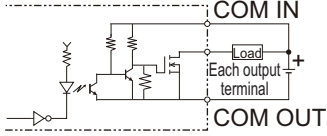
Item	Specifications
Internal circuit diagram	 <p>The diagram shows an NPN transistor circuit. The emitter is connected to ground. The base is connected to an input terminal labeled 'COM IN' through a resistor. The collector is connected to a positive supply rail through a resistor. The output terminal is labeled 'COM OUT' and is connected to the collector. A load is connected between the output terminal and ground. The text 'Each output terminal' is written near the load.</p>

b) Internal specifications for PNP connection

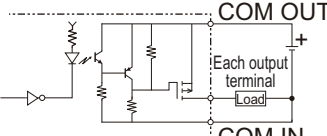
Item	Specifications
Internal circuit diagram	 <p>The diagram shows a PNP transistor circuit. The emitter is connected to a positive supply rail through a resistor. The base is connected to an input terminal labeled 'COM IN' through a resistor. The collector is connected to ground through a resistor. The output terminal is labeled 'COM OUT' and is connected to the collector. A load is connected between the output terminal and the positive supply rail. The text 'Each output terminal' is written near the load.</p>

## 6-2 EtherCAT Interface

EtherCAT interface is supported FH-5050 series.

### 6-2-1 FH-5050



#### Precautions for Safe Use

- Use only the cables designed specifically for the product. Use of other products may result in malfunction or damage of the product.
- Always turn OFF the power of the FH-L series Sensor Controller and peripheral devices before connecting or disconnecting a camera or cable. Connecting the cable with power supplied may result in damage of the camera or peripheral devices.
- Since cables to which bending is frequently applied is easily broken, use the robotic cable type (bending resistant cable) to prevent damages.
- Do not apply torsion stress to cables. If not, it may cause damage to cables.
- Secure the minimum bending radius of cables. If not, it may cause damage to cables.



#### Precautions for Correct Use

- Check the following items on the communications cables that are used in the network.
  - Are there any breaks?
  - Are there any shorts?
  - Are there any connector problems?
- When you connect the cable to the communications connectors on devices, firmly insert the communications cable connector until it locks in place.
- Do not lay the communications cables together with high-voltage lines.
- Do not lay the communications cable near devices that generate noise.
- Do not lay the communications cables in locations subject to high temperatures or high humidity.
- Do not lay the communications cables in locations subject to excessive dirt and dust or to oil mist or other contaminants.

### Cable

- Connect a straight LAN cable.
- Use an STP cable of category 5e or higher, which is double-shielded with aluminum tape and braided cord.
- The maximum cable length is 100 [m]. Some cables, however, are not guaranteed with 100 [m]. Generally, the transmission performance of conductor twisted cables become worse than that of single cables, so that 100 [m] is not guaranteed. For details, contact your cable manufacturer.

### I/O Connector

- For electrical specifications, complying with IEEE 802.3 standard and use RJ45 8-pin modular connector (complying with ISO 8877) supporting category 5e or higher.
- When selecting connectors, check that it is suitable for the cable to be used. Items to be checked are conductor size, stranded or single, two pairs or four pairs, outer diameter, and so on.

## Pin Layout

Pin assignment	Pin No.	Signal name	Abbr.	Signal direction
	1	Transmission data +	TD +	Output
	2	Transmission data -	TD -	Output
	3	Reception data +	RD +	Input
	4	Not used	NC	-
	5	Not used	NC	-
	6	Reception data -	RD -	Input
	7	Not used	NC	-
	8	Not used	NC	-
	Connector hood	Security ground	FG	-

## Wiring

- Connect both ends of the cable shield to the connector hood.
- Apply the T568A method below.

Pin No.	Wire color	Wire color	Pin No.
1	White-Green	White-Green	1
2	Green	Green	2
3	White-Orange	White-Orange	3
4	Blue	Blue	4
5	White-Blue	White-Blue	5
6	Orange	Orange	6
7	White-Brown	White-Brown	7
8	Brown	Brown	8
Connector hood	Shielded cable	Shielded cable	Connector hood

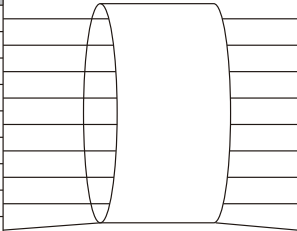

## 6-3 Ethernet Interface

Ethernet port of Sensor Controller is used for EtherNet/IP or Serial (Ethernet) communication. The Ethernet port can be changed depending on Sensor Controller series. Be sure to check the series you are attempting to use.

### 6-3-1 FH-5050



#### Precautions for Safe Use

- Use only the cables designed specifically for the product. Use of other products may result in malfunction or damage of the product.
- Always turn OFF the power of the FH-L series Sensor Controller and peripheral devices before connecting or disconnecting a camera or cable. Connecting the cable with power supplied may result in damage of the camera or peripheral devices.
- Since cables to which bending is frequently applied is easily broken, use the robotic cable type (bending resistant cable) to prevent damages.
- Do not apply torsion stress to cables. If not, it may cause damage to cables.
- Secure the minimum bending radius of cables. If not, it may cause damage to cables.



#### Precautions for Correct Use

- Check the following items on the communications cables that are used in the network.
  - Are there any breaks?
  - Are there any shorts?
  - Are there any connector problems?
- When you connect the cable to the communications connectors on devices, firmly insert the communications cable connector until it locks in place.
- Do not lay the communications cables together with high-voltage lines.
- Do not lay the communications cable near devices that generate noise.
- Do not lay the communications cables in locations subject to high temperatures or high humidity.
- Do not lay the communications cables in locations subject to excessive dirt and dust or to oil mist or other contaminants.

Ethernet port is 2.

#### FH-5050

- Upper port: Ethernet port for connecting a 3D vision sensor.
- Lower port: Ethernet port for connecting a robot controller.

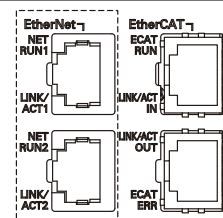

### Cable

- Use the camera cable (Ethernet cable FHV-VNBX2 / FHV-VNLBX2 / FHV-VNBX / FHV-VNLBX: sold separately) to connect to the 3D vision sensor.
- Connect a straight or cross LAN cable.

- The transmission rate you use determines available cables and connectors.
- For 100BASE-TX or 10BASE-T, use an STP (shielded twist pair) cable with category 5 or higher.
- For 1000BASE-T, use an STP cable (double-shielded with aluminum tape and braided cord) with category 5e or higher.

## I/O Connector

- For electrical specifications, complying with IEEE 802.3 standard and use RJ45 8-pin modular connector (complying with ISO 8877) supporting category 5e or higher.
- When selecting connectors, check that it is suitable for the cable to be used. Items to be checked are conductor size, stranded or single, two pairs or four pairs, outer diameter, and so on.

## Pin Layout

### ● 10Base-T and 100Base-TX

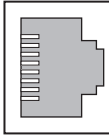
Pin assignment	Pin No.	Signal name	Abbr.	Signal direction
	1	Transmission data +	TD +	Output
	2	Transmission data -	TD -	Output
	3	Reception data +	RD +	Input
	4	Not used	-	-
	5	Not used	-	-
	6	Reception data -	RD -	Input
	7	Not used	-	-
	8	Not used	-	-

### ● 1000Base-T

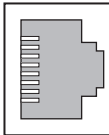
Pin assignment	Pin No.	Signal name	Abbr.	Signal direction
	1	Communication data DA +	BI_DA +	I/O
	2	Communication data DA -	DI_DA -	I/O
	3	Communication data DB +	BI_DB +	I/O
	4	Communication data DB -	BI_DC +	I/O
	5	Communication data DC +	BI_DC -	I/O
	6	Communication data DC -	BI_DB -	I/O
	7	Communication data DD +	BI_DD +	I/O
	8	Communication data DD -	BI_DD -	I/O

## Wire

Describes the connection processing to connector hood of shield as the following. The connection processing is changed according to the transfer speed.

- 10 BASE-T/100 BASE-TX  
Connect both ends of the cable shield to the connector hood. Or, connect only the shield of one end of the cable, switching hub side, to the connector hood.
- 1000 BASE-T



Connect both ends of the cable shield to the connector hood.





# Index



# Index

## Numerics

2D lighting unit.....	3-10
3D Cameras and Related.....	1-3
3D lighting unit.....	3-10
3D vision sensor.....	1-3
3D Vision Sensor.....	3-9
Component Names and Functions.....	3-10
Dimensions.....	3-11
Measurement Range and Field of View.....	3-12
Specification.....	3-9

## A

Accessibility for Operation and Maintenance.....	5-21
ACCESS LED.....	3-6
Accessories.....	1-7
Ambient temperature and humidity.....	5-20
Analog Lighting Controller.....	1-7

## B

Basic System of Measurement.....	2-2
----------------------------------	-----

## C

Cable.....	1-8
Cable with Rugged type Connectors on Both Ends (M12/ RJ45).....	1-8
Cable with Rugged type Connectors on Both Ends (RJ45/ RJ45).....	1-8
Cable with Standard type Connectors on Both Ends (RJ45/ RJ45).....	1-8
Calibration Target.....	1-5, 3-19
Dimensions.....	3-19
Specification.....	3-19
Camera.....	1-3
Camera and Cables.....	3-9
Camera Cable.....	1-3, 3-13
Specification.....	3-13
Camera calibration target.....	3-19
Camera Calibration Target.....	1-5
Camera connector.....	3-6
Camera I/O Cable.....	1-3, 3-17
Specification.....	3-17
Camera Installation.....	5-11
FH-5050.....	5-11
Concept of Measurement Processing.....	2-3
Configuration.....	3-1
confirm the Package.....	1-1
Connection of Terminal Block.....	5-5
Connector for camera cable (Ethernet cable).....	3-10
Connector for camera I/O cable.....	3-10
Connector-Terminal Block Conversion Units, General-pur- pose devices.....	1-8

## D

DVI-Analog Conversion Cable for Touch Panel Monitor....	1-6
DVI-Analog Conversion Cable for Touch Panel Monitor: FH- VMDA	
Dimensions.....	3-25
DVI-I connector.....	3-5
DVI-I -RGB Conversion Connector.....	1-6
DVI-I -RGB Conversion Connector: FH-VMRGB	
Dimensions.....	3-29

## E

ECAT ERROR.....	3-7
ECAT RUN.....	3-7
Encoder connector.....	3-6
ERROR LED.....	3-6
EtherCAT address setup volume.....	3-5
EtherCAT communication connector (IN).....	3-6
EtherCAT communication connector (OUT).....	3-6
EtherCAT ERR LED.....	3-6
EtherCAT Interface.....	6-11
FH-5050.....	6-11
Cable.....	6-11
I/O Connector.....	6-11
Pin Layout.....	6-12
Wiring.....	6-12
EtherCAT junction slaves.....	1-7
EtherCAT LINK/ACT IN LED.....	3-6
EtherCAT LINK/ACT OUT LED.....	3-6
EtherCAT RUN LED.....	3-6
EtherCAT status indicator LED.....	3-7
Ethernet Cable.....	3-13
Ethernet Cables.....	1-3
Ethernet connector.....	3-5
Ethernet Interface.....	6-13
FH-5050.....	6-13
Cable.....	6-13
I/O Connector.....	6-14
Pin Layout.....	6-14
Wire.....	6-14
Ethernet LINK/ACT1 LED.....	3-7
Ethernet LINK/ACT2 LED.....	3-7
Ethernet NET RUN1 LED.....	3-7
Ethernet NET RUN2 LED.....	3-7
External Lighting.....	1-7

## F

Ferrite core for camera cable.....	1-2
FH-5050.....	1-2
Component Names and Functions.....	3-5
Dimensions.....	3-8
FH-5050 for 3D Robot Vision	
Specification.....	3-2
FH Application Software.....	1-4

FH-MT12.....	1-6
FH-SMDA-GS050B.....	1-3
FH-UM3D1.....	1-4
FH-VM DA □M.....	1-6
FH-VMRGB.....	1-6
FH-VSDX.....	3-17
FH-VSDX-BX.....	1-3
FH-VSDX-LBX.....	1-3
FH-VUAB □M.....	1-6
FHV-VNBX.....	1-3, 3-13
FHV-VNBX2.....	1-3, 3-13
FHV-VNLBX.....	1-3, 3-14
FHV-VNLBX2.....	1-3, 3-14
FH-XCAL-R.....	1-5, 3-19
FH-XCAL-S.....	1-5, 3-19
FH-XCN.....	1-2
F-LINK-E 0.5mm x 4P.....	1-9
Flow of Use Procedure.....	2-5
FL Series.....	1-7
FLV-ATC Series.....	1-7
FLV Series.....	1-7
FZ-DU.....	1-7
FZ-M08.....	1-6
FZ-MEM16G.....	1-7
FZ-MEM2G.....	1-7
FZ-MEM8G.....	1-7
FZ-VM.....	1-6
<b>G</b>	
General Compliance Information and Instructions for EU.....	1-2
GX-JC03.....	1-7
<b>H</b>	
Handeye Calibration Target.....	1-5
HandEye calibration target.....	3-19
Handling and Installation Environment.....	4-1
FH-5050.....	4-2
Handling a SD memory card.....	4-3
Handling of Sensor Controller.....	4-2, 4-3
HMC-SD292.....	1-7
HMC-SD492.....	1-7
<b>I</b>	
I/O (Parallel) connector (control lines, data lines).....	3-5
I/O Cables.....	1-3
I/O Interface.....	6-1
EtherCAT Interface.....	6-11
Ethernet Interface.....	6-13
Parallel Interface.....	6-2
IETP-SB.....	1-9
Imaging unit.....	3-10
Industrial Switching Hubs for EtherNet/IP and Ethernet.....	1-7
Insert/Remove SD Memory Card or USB Flash Drive.....	5-17
FH-5050.....	5-17
Installation and Storage Sites.....	4-3
Installation Environment.....	4-2
Installation in a Control Panel.....	5-19
FH-5050.....	5-19
Installation of 3D Vision Sensor.....	5-12
Instruction Installation Manual for FH series.....	1-2
Instruction sheet.....	1-2
Internal Specifications for Parallel Interface.....	6-8
<b>K</b>	
KETH-PSB-OMR.....	1-9
KETH-SB.....	1-9
<b>L</b>	
L/A IN.....	3-7
L/A OUT.....	3-7
LCD and Cable.....	3-27
Component Names and Functions.....	3-28
Dimensions.....	3-29
Wire.....	3-28
LCD Monitor.....	
Dimensions.....	3-29
Specification.....	3-27
LCD Monitor 8.4 inches for Box-type Controllers.....	1-6
LCD Monitor and Cable.....	1-6
LCD Monitor Cable.....	1-6
Specification.....	3-27
LED indicator lamp.....	3-22
LED indicator lamp (for power).....	3-28
LED indicator lamp (for SYNC).....	3-28
Lighting.....	1-7
Lighting Controller.....	1-7
For FLV-Series.....	1-7
<b>M</b>	
Maintenance.....	4-3
Membership registration.....	1-2
Monitor.....	1-6
Monitor Cable: FZ-VM.....	
Dimensions.....	3-29
Monitor connector (analog RGB).....	3-22
Mounting of Sensor Controller.....	5-8
Mouse.....	1-7
MPS588.....	1-9
MPS588-C.....	1-9
<b>N</b>	
NETSTAR-C5E SAB 0.5 x 4P CP.....	1-9
NSD6-002GS(P11SEI).....	1-7
NSD6-004GS(P11SEI).....	1-7
<b>O</b>	
Operation indicator.....	3-10
Orientation of Product.....	4-3
OSD Menu button.....	3-22
Overview of FH series.....	2-1

<b>P</b>	
Parallel I/O Cable.....	1-8
Parallel I/O Cable for Connector-terminal Conversion Unit.....	1-8
Parallel Interface.....	6-2
Cable, I/O connector and Terminal Block.....	6-4
FH-5050.....	6-2
Interface Specification.....	6-2
Pin Layout.....	6-5
PNET/B.....	1-9
POWER LED.....	3-6
Power supply terminal.....	3-22, 3-28
Power supply terminal connector.....	3-6
<b>R</b>	
Recommended EtherCAT Communications Cables.....	1-8
Recommended EtherNet/IP Communications Cables.....	1-8
Recommended Power Source of Sensor Controller.....	5-7
RS-232C Cable for Touch Panel Monitor.....	1-6
RS-232C Cable for Touch Panel Monitor: XW2Z-□□□PP-1	
Dimensions.....	3-25
RS-232C connector.....	3-5
Rugged type Cable with Connectors on Both Ends (M12 L/RJ45).....	1-9
RUN LED.....	3-6
<b>S</b>	
SD BUSY LED.....	3-6
SD card.....	1-7
SD memory card installation connector.....	3-5
SD POWER LED.....	3-6
Sensor Controller.....	1-2, 3-2
Sensor Controller Installation.....	5-5
FH-5050.....	5-5
Setup and Wiring.....	5-1
Setup Touch Panel Monitor or Monitor.....	5-10
FH-5050.....	5-10
Simulation Software.....	5-18
Sold Separately.....	1-6
System Configuration.....	2-4
<b>T</b>	
The Example of a System Configuration.....	2-4
Touch Panel Monitor.....	3-21
Component Names and Functions.....	3-22
Dimensions.....	3-25
Specification.....	3-21
Touch Panel Monitor 12.1 inches.....	1-6
Touch Panel Monitor and Cable.....	3-21
Connection Example.....	3-23
Dimensions.....	3-25
RS-232C Connection (Cable Length Up to 10 m).....	3-24
USB Connection (Cable Length Up to 5 m).....	3-23
Wiring.....	3-24
Touch Panel Monitor and Cables.....	1-6
Touch Panel Monitor Cable.....	3-23
Specification.....	3-23
Touch Panel Monitor - FH-MT12.....	3-21
Touch pen.....	3-22
Touch pen holder.....	3-22
<b>U</b>	
USB/Monitor Switcher.....	1-7
USB Cable for Touch Panel Monitor.....	1-6
USB Cable for Touch Panel Monitor: FH-VUAB	
Dimensions.....	3-26
USB connector.....	3-5
USB flash drive.....	1-7
USB retaining bracket.....	3-22
Use by Connecting Software.....	5-18
<b>V</b>	
VESA mounting hole.....	3-22, 3-28
Vibration and Shock.....	5-20
Video input (RGB).....	3-28
<b>W</b>	
W4S1-03B.....	1-7
W4S1-05B.....	1-7
W4S1-05C.....	1-7
When turning ON and OFF.....	5-2
FH-5050.....	5-2
<b>X</b>	
XS5W-T421-□MC-K.....	1-8
XS5W-T421-□MD-K.....	1-8
XS5W-T422-□MC-K.....	1-9
XS6G-T421-1.....	1-9
XS6W-6LSZH8SS□CM-Y.....	1-8
XW2R-□34GD-T.....	1-8
XW2Z-□□□EE.....	1-8
XW2Z-□□□PP-1.....	1-6
XW2Z-S013-□.....	1-8, 6-5



**OMRON Corporation Industrial Automation Company**

**Kyoto, JAPAN**

**Contact : [www.ia.omron.com](http://www.ia.omron.com)**

**Regional Headquarters**

**OMRON EUROPE B.V.**

Wegalaan 67-69, 2132 JD Hoofddorp  
The Netherlands  
Tel: (31) 2356-81-300 Fax: (31) 2356-81-388

**OMRON ELECTRONICS LLC**

2895 Greenspoint Parkway, Suite 200  
Hoffman Estates, IL 60169 U.S.A.  
Tel: (1) 847-843-7900 Fax: (1) 847-843-7787

**OMRON ASIA PACIFIC PTE. LTD.**

438B Alexandra Road, #08-01/02 Alexandra  
Technopark, Singapore 119968  
Tel: (65) 6835-3011 Fax: (65) 6835-2711

**OMRON (CHINA) CO., LTD.**

Room 2211, Bank of China Tower,  
200 Yin Cheng Zhong Road,  
PuDong New Area, Shanghai, 200120, China  
Tel: (86) 21-5037-2222 Fax: (86) 21-5037-2200

**Authorized Distributor:**

©OMRON Corporation 2021-2022 All Rights Reserved.  
In the interest of product improvement,  
specifications are subject to change without notice.

**Cat. No. Z436-E1-03** 1222  
Printed in Japan