

Quick Start Guide

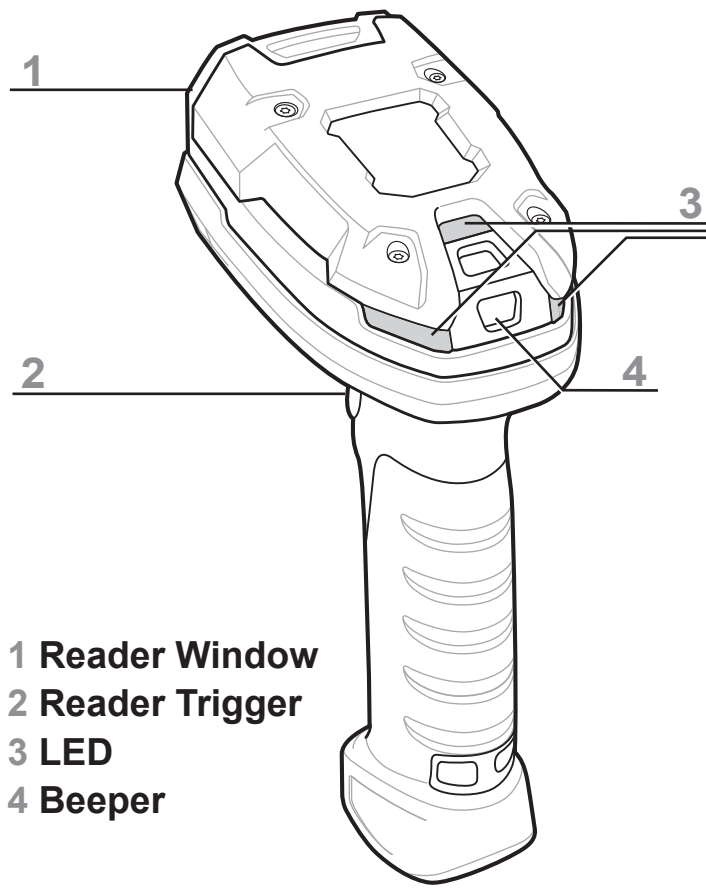

- 1 Reader Window
- 2 Reader Trigger
- 3 LED
- 4 Beeper

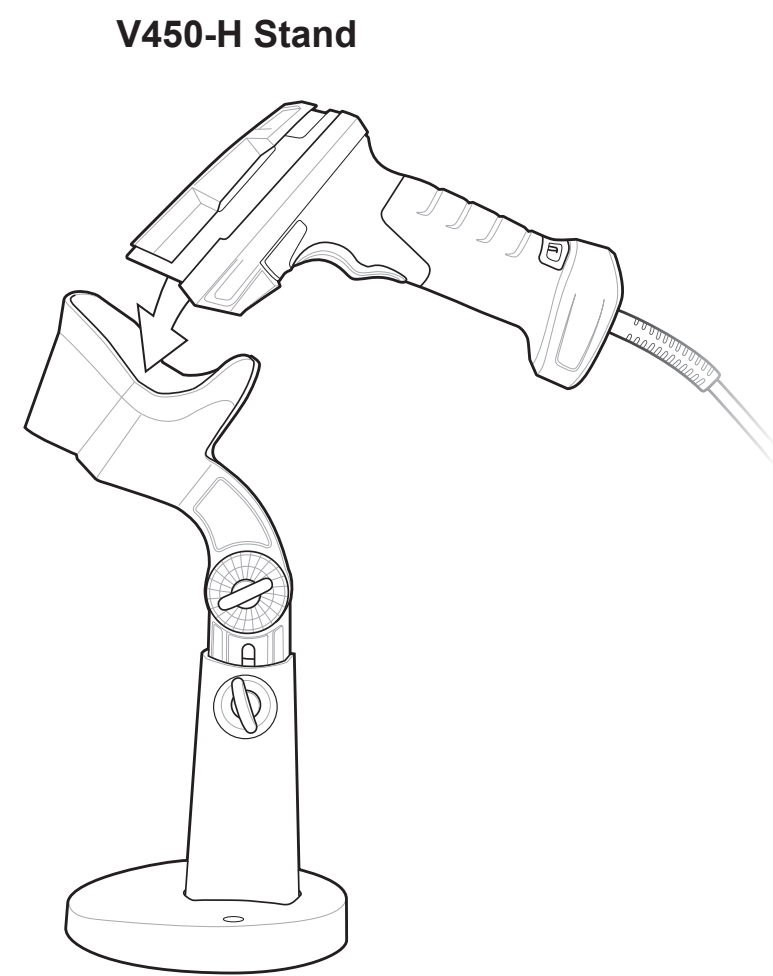

V450-H Stand

Cable Attachment

1. Insert cable fully so connector is flush with reader surface.
2. Loosen metal lock plate screws using a PH1 driver.
3. Slide lock plate to fully locked position.
4. Tighten screw using a PH1 driver (torque: 5 in-lb).

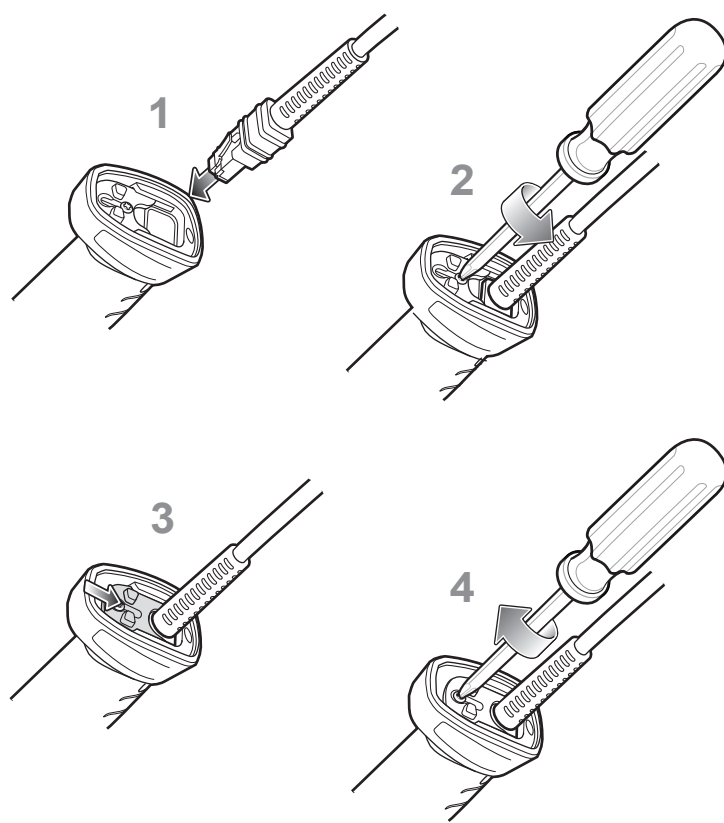

Return to Factory Defaults / Add an Enter Key

Return to Factory Defaults
Decode the symbol below to return reader parameters to factory defaults.



Add an Enter Key (Carriage Return / Line Feed)
Decode the symbol below to add an Enter key after decoded data.



Add a Tab Key

Add a Tab Key
Decode the symbol below to add a Tab key after decoded data.



USB Caps Lock Override Options

USB - OVERRIDE CAPS LOCK KEY (ENABLE)

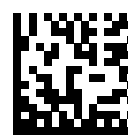

*USB - DO NOT OVERRIDE CAPS LOCK KEY (DISABLE)



Step 1 – Set Up Host Interface

USB

Note: Cables may vary depending on configuration.

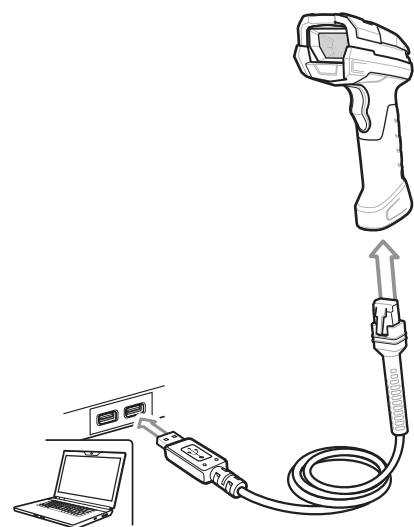

Decode one of the symbols below.

The interface cable automatically detects the host interface type and uses the default setting. If the default (*) does not meet your requirements, Decode the other host symbol below.

*USB HID KEYBOARD EMULATION



SNAPI WITH IMAGING INTERFACE



USB CDC HOST (VIRTUAL COM)



Step 2 – Install WebLink_{PC} and Connect

Install

The WebLink_{PC} installer is found on Omron's Download Center at www.automation.omron.com/weblinkpc

Minimum PC Requirements

- Intel® Core™2 Duo Processor (Core™i3 recommended)
- Microsoft Windows 7 32-bit (Windows 7 64-bit or Windows 10 recommended)
- Internet Explorer 11 or higher, Edge, Firefox, or Opera (Chrome recommended)
- 1 GB/128 MB Video RAM (2 GB RAM/128 MB Video RAM recommended)
- 100 MB hard drive space (500 MB recommended)
- 16-bit color display (32-bit recommended)
- 3.0 Windows Experience Index (4.0 recommended)

Connect

To start WebLink_{PC}, double-click the icon placed on your desktop during installation.



You can also start WebLink_{PC} by opening a browser of your choice and typing <http://localhost:8090> or <http://127.0.0.1:8090> in the address bar.

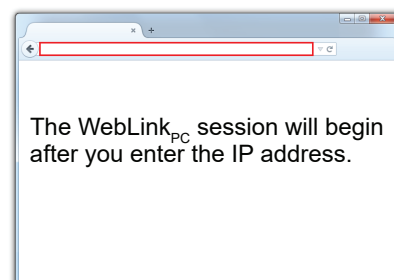

Step 3 – Explore the Start View

The **Start** view shows all the readers available to the system. The **Reader Model**, **Serial Number**, and **Firmware Version** of each reader are displayed. This view also allows you to choose **Assisted Setup**, **Create a New Setup**, or **Load a Setup**. The **Gear icon** in the upper right brings up the **Settings Menu**.

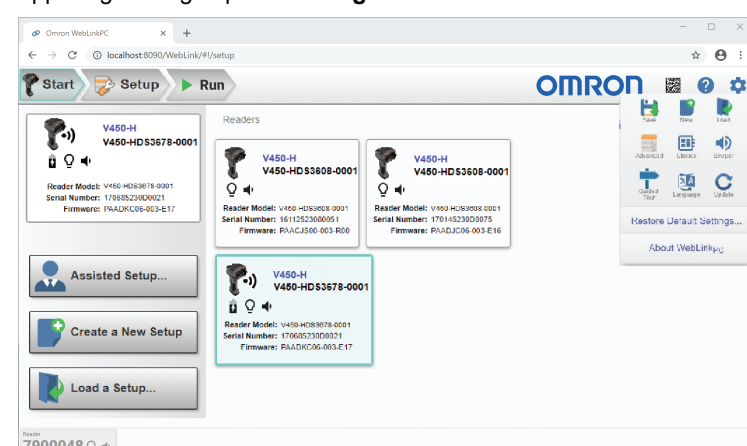

Step 4 – Create or Load a Setup

Assisted Setup

When you click the **Assisted Setup** button in the **Start** view, a dialog appears asking a series of application-related questions. Based on your answers, WebLink_{PC} generates your initial setup automatically. Once the setup is created, you can fine-tune its parameters in the **Setup** view.

Create a New Setup

The **Start** view also allows you to create a **New Setup** without using **Assisted Setup**. When you click the **Create a New Setup** button, WebLink_{PC} searches for any differences from default in the reader parameters. If no differences from default are found, the **Setup** view appears. If differences from default are found, an alert appears asking if you want to restore default settings.

Load a Setup

Select **Load a Setup** to load an existing .ris WebLink_{PC} setup file.

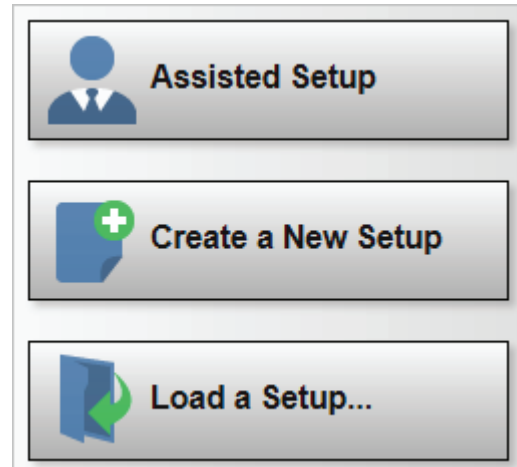

Step 5 – Explore the Setup View

The **Setup** view allows you to configure the reader, view the current captured image, and view decoded symbol data.

The following read cycle steps are shown at the left side of the screen:

- Cycle
- Performance
- Decode
- Format Output

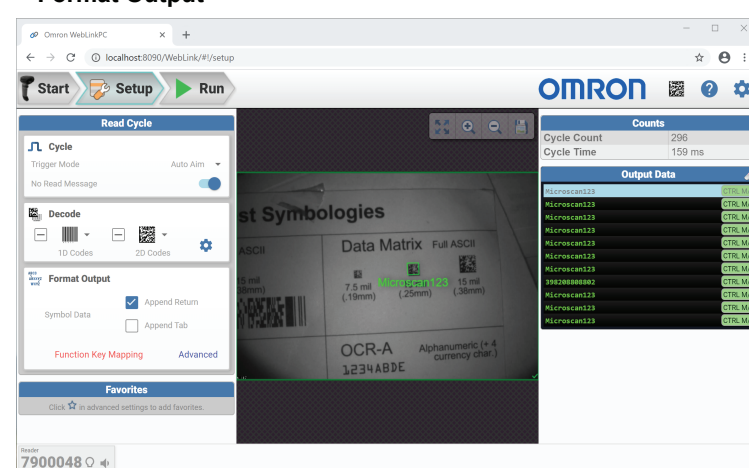

Step 6 – Configure the Reader

Cycle Step

The **Cycle** step allows you to choose between **Manual** and **Presentation** trigger modes. In **Manual** mode, a decode is attempted when you pull the trigger. In **Presentation** mode, the read cycle begins when a symbol is detected moving into the reader's field of view.

Note: The reader is automatically set to **Presentation** mode when placed in the V450-H Stand.

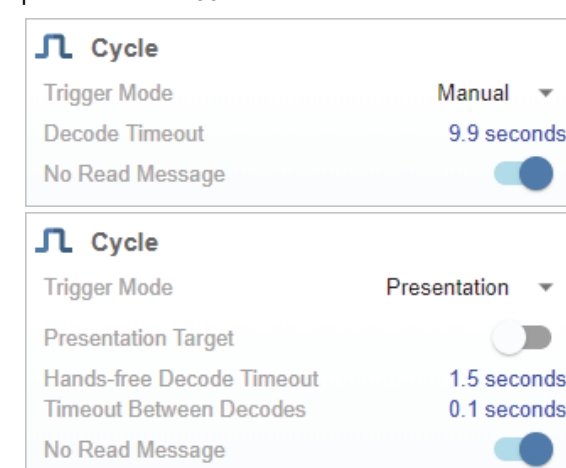

Step 6 – Configure the Reader (Continued)

Performance Step (DPM Optimization)

The **Performance** step allows you to optimize the reader for **Direct Part Mark (DPM)** decoding. A DPM is a permanent mark created by laser etch, chemical etch, or other method, directly on a substrate. DPMs are often harder to read than other symbols, and may require a few attempts before finding optimal settings. The **Decoder Effort** slider has four settings: **Level 1**, corresponding to **Min** on the slider; **Level 2**; **Level 3**; and **Level 4**, corresponding to **Max** on the slider. As **Decoder Effort** is moved toward **Max**, the decoder spends an increasing amount of time trying to decode the symbol.

In **Level 4**, you can also enable the **Enhance** option, which improves readability by allowing additional processing for poorly-formed marks. The **Illumination** options are **Direct**, **Indirect**, and **Cycle**.

Clicking the **Question Mark icon** brings up a dialog with more detail about each level of decoder effort.

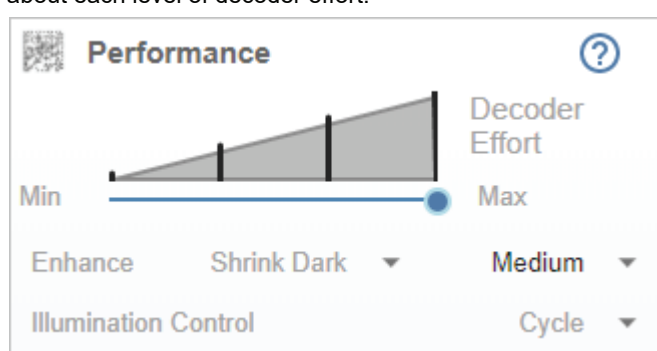

Step 6 – Configure the Reader (Continued)

Decode Step

The **Decode** step allows you to select which symbologies to enable and disable. Clicking the **1D** and **2D** checkboxes will enable or disable all the symbologies in that group. The **Gear icon** brings up a **Symbology Settings** dialog, allowing you to modify specific parameters.

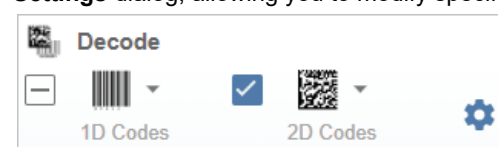

Format Output Step

Format Output allows you to configure preambles and postambles to add to symbol data output. The **Simplified** version of this control allows you to **Append Return** or **Append Tab** after each string of data output. The **Advanced** version allows you to choose from a wide variety of keyboard characters that can be output as a preamble or postamble. You can also add a second postamble if required.

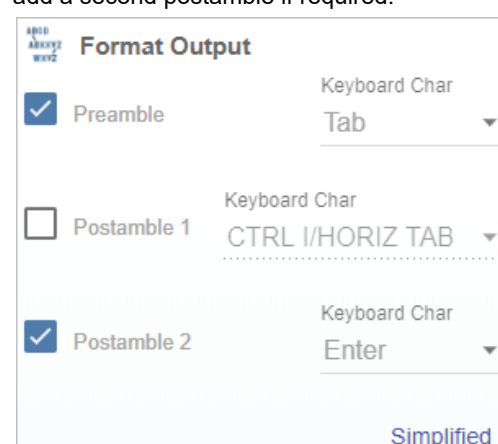

Step 7 – Run the Application

The **Run** view allows you to keep track of your application during runtime. The current captured image is shown along with a row of image control tools. A history of decoded symbol data is shown in the right pane along with any preambles or postambles that have been defined.

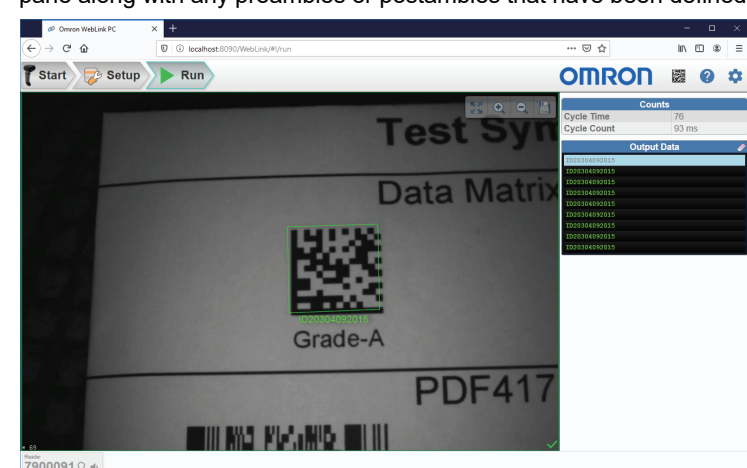

The **Output Data** display in the right pane shows a list of previous read cycle results. Each result is selectable and erasable.

Image control tools are available at the upper right of the image view.

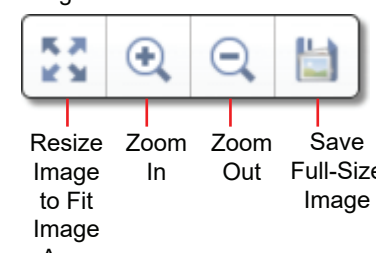

V450-H Wired Handheld DPM Reader

POST IN WORK AREA

V450-H Aiming



012345

For best results, aim the dot at the center of the symbol.

Sample Symbols



Data Matrix
OmronMicroscan1234567890



QR Code
OmronMicroscan1234567890



Code 39
OMRON1234



Interleaved 2 of 5
1234567890

RECOMMENDED USAGE GUIDE - OPTIMUM BODY POSTURE

Avoid Extreme Wrist Angles

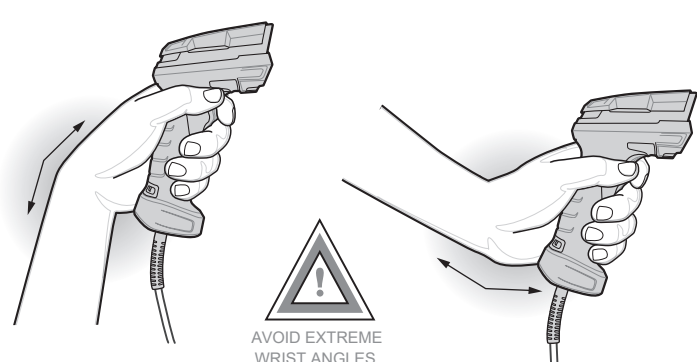

Avoid Bending

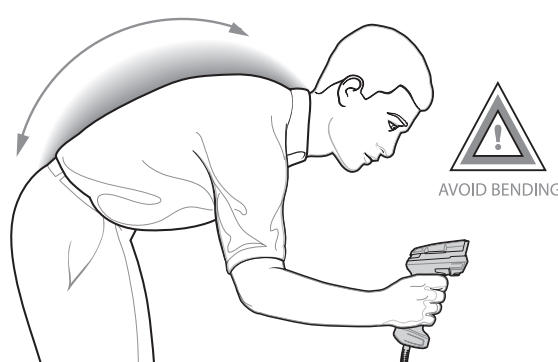

Avoid Reaching

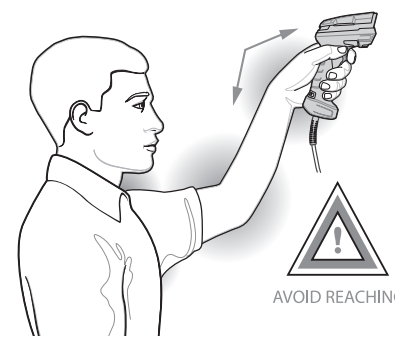

BEEPER INDICATIONS

Indication	Beeper Sequence
Power up	Low/medium/high beep
Barcode decoded	Medium beep
Transmission error detected; data is ignored	4 long low beeps
Successful parameter setting	High/low/high/low beep
Correct programming sequence performed	High/low beep
Incorrect programming sequence, or Cancel barcode decoded	Low/high beep

LED INDICATIONS

Handheld Decoding	
Indication	LED Indicator
Reader is on and ready to decode, or no power to reader	Off
Barcode is successfully decoded	Green
Transmission error	Red
Hands-Free (Presentation) Decoding	
No power to reader	Off
Reader is ready to decode	Green
Barcode is successfully decoded	Off Momentarily
Transmission error	Red

TROUBLESHOOTING

Reader not Working	
No power to reader	Check system power
Reader is disabled	Ensure correct interface cable is used
Reader Decoding Barcode, but Data not Transmitting to Host	
Host interface not configured properly	Decode appropriate host parameter barcodes
Interface cable is loose	Ensure all cable connections are secure
Invalid rule	Program the correct rules

Reader not Decoding Barcode	
Reader not programmed for barcode type	Ensure reader is programmed to decode the type of barcode scanned
Barcode unreadable	Ensure barcode is not defaced; try decoding test barcode of the same barcode type
Distance between reader and barcode incorrect	Move reader closer to, not farther from barcode
Reader Data Incorrectly Displayed on Host	
Host interface not configured properly	Decode appropriate host parameter barcodes
Region improperly configured	Select appropriate country and language encoding scheme

REGULATORY INFORMATION

Warranty

For current warranty information, see:
ia.omron.com/product/cautions/common/agreements-before-purchase/index.html

Technical Support

For technical support, see:
ia.omron.com/support/

Waste Electrical and Electronic Equipment (WEEE)

English: For EU Customers: All products at the end of their life must be returned to Omron Microscan for recycling. For information on how to return product, please go to: www.ia.omron.com.
Bulgarian: За клиентите от ЕС: След края на ползването им живот всички продукти трябва да се връщат на Omron Microscan за рециклиране. За информацията относно връщането на продукти, моля отидете на адрес: www.ia.omron.com.
Czech: Pro zákazníky z EU: Všechny produkty je nutné po skončení jejich životnosti vrátit společnosti Omron Microscan k recyklaci. Informace o způsobu vrácení produktu najdete na webové stránce: www.ia.omron.com.
Danish: Til kunder i EU: Alle produkter skal returneres til Omron Microscan til recirkulering, når de er udtjente. Læs oplysningerne om returnering af produkter på: www.ia.omron.com.
German: Für Kunden innerhalb der EU: Alle Produkte müssen am Ende ihrer Lebensdauer zum Recycling an Omron Microscan zurückgeschickt werden. Informationen zur Rücksendung von Produkten finden Sie unter www.ia.omron.com.
Greek: Για πελάτες στην Ε.Ε.: Όλα τα προϊόντα, στο τέλος της διάρκειας ζωής τους, πρέπει να επιστρέφονται στην Omron Microscan για ανακύκλωση. Για περισσότερες πληροφορίες σχετικά με την επιστροφή ενός προϊόντος, επισκεφθείτε τη διεύθυνση www.ia.omron.com στο Διαδίκτυο.
Estonian: EL klientidele: kõik tooted tuleb nende eluea lõppedes tagastada taaskasutamise eesmärgil Omron Microscan'ile. Lisainformatsiooni saamiseks toote tagastamise kohta külastage palun aadressi: www.ia.omron.com.
Spanish: Para clientes en la Unión Europea: todos los productos deberán entregarse a Omron Microscan al final del ciclo de vida para que sean reciclados. Si desea más informa- ción sobre cómo devolver un producto, visite: www.ia.omron.com.
French: Clients de l'Union Européenne : Tous les produits en fin de cycle de vie doivent être retournés à Omron Microscan pour recyclage. Pour de plus amples informations sur le retour de produits, consultez : www.ia.omron.com.
Italiano: per i clienti dell'UE: tutti i prodotti che sono giunti al termine del rispettivo ciclo di vita devono essere restituiti a Omron Microscan al fine di consentirne il riciclaggio. Per informazioni sulle modalità di restituzione, visitate il seguente sito Web: www.ia.omron.com.
Latvian: ES klientiem: visi produkti pēc to kalpošanas mūža beigām ir jānogādā atpakaļ Omron Microscan atbilstošajai pārstrādei. Lai iegūtu informāciju par produktu nogādāšanu Omron Microscan, lūdzu, skatiet: www.ia.omron.com.
Lithuanian: ES vartotojams: visi gaminiai, pasibaigus jų eksploatacijos laikui, turi būti grąžinti utilizuoti į kompaniją „Omron Microscan“. Daugiau informacijos, kaip grąžinti gaminį, rasite: www.ia.omron.com.
Hungarian: Az EU-ban vásárlóknak: Minden törökment termékét a Omron Microscan vállalatához kell eljuttatni újrahasznosítás céljából. A termék visszaküldésének módjával kapcsolatos tudnivalókat látogasson el a www.ia.omron.com weboldarra.
Maltese: Għal klijenti fl-UE: Il-prodotti kollha li jkun uwalu fl-aħħar tal-ħajja ta' l-użu tagħhom, iridu jiġu ritornati għand Omron Microscan għar-riċiklaġġ. Għal aktar tagħrif dwar kif għandek lirtorna l-prodott, jekk jogħġbok zur: www.ia.omron.com.
Dutch: Voor klanten in de EU: alle producten dienen aan het einde van hun levensduur naar Omron Microscan te worden teruggezonden voor recycling. Raadpleeg www.ia.omron.com voor meer informatie over het terugzenden van producten.
Polish: Klienci z obszaru Unii Europejskiej: Produkty wycofane z eksploatacji należy zwrócić do firmy Omron Microscan w celu ich utylizacji. Informacje na temat zwrotu produkt ów znajdują się na stronie internetowej www.ia.omron.com.
Portuguese: Para clientes da UE: todos os produtos no fim de vida devem ser devolvidos à Omron Microscan para reciclagem. Para obter informações sobre como devolver o produto, o visite: www.ia.omron.com.
Romanian: Pentru clienții din UE: Toate produsele, la sfârșitul duratei lor de funcționare, trebuie returnate la Omron Microscan pentru reciclare. Pentru informații despre returnarea produsului, accesați: www.ia.omron.com.
Slovenian: Pro zăkaznikov z krajinj EU: Všetky výrobky musia b yť po uplynutí doby ich životnosti vrátené spoločnosti Omron Microscan na recykláciu. Blížšie informácie o vrátení výrobkov nájdete na: www.ia.omron.com.
Slovak: Za kupce v EU: vsi izdelki se morajo po poteku življenjske dobe vrniti podjetju Omron Microscan za reciklazio. Za informacije o vrabilu izdelka obiščite: www.ia.omron.com.
Finnish: Asiakkas Euroopan unionin alueella: Kaikki tuotteet on palautettava kierrätettäväksi Omron Microscan-yhtiölle, kun tuotetta ei enää käytetä. Lisätietoja tuotteesta on palauttamisesta on osoitteessa www.ia.omron.com.
Swedish: För kunder inom EU: Alla produkter som uppnått sin livslängd måste returneras till Omron Microscan för återvinning. Information om hur du returnerar produkten finns p å www.ia.omron.com.
Turkish: AB Müşterileri için: Kullanım süresi dolan tüm ürünler geri dönüşümü için Omron Microscan'ya iade edilmelidir. Ürünlerin nasıl iade edileceği hakkında bilgi için lütfen şu adresi ziyaret edin: www.ia.omron.com.
Croatian: Za kupce u Europskoj uniji: Svi se proizvodi po isteku vijeka trajanja moraju vratiti tvrtki Omron Microscan na recikliranje. Informacije o načinu vraćanja proizvoda potražite na web-stranici: www.ia.omron.com.

TURKISH WEEE Statement of Compliance
EEE Yönetmeliğine Uygundur

Health and Safety Recommendations



Ergonomic Recommendations

Caution: In order to avoid or minimize the potential risk of ergonomic injury follow the recommendations below. Consult with your local Health & Safety Manager to ensure that you are adhering to your company's safety programs to prevent employee injury.

- Reduce or eliminate repetitive motion
- Maintain a natural position
- Reduce or eliminate excessive force
- Keep objects that are used frequently within easy reach
- Perform tasks at correct heights
- Reduce or eliminate vibration
- Reduce or eliminate direct pressure
- Provide adjustable workstations
- Provide adequate clearance
- Provide a suitable working environment
- Improve work procedures

Regulatory Information

This device is approved under Omron Microscan Systems. This guide applies to Model Number DS3608. All Omron devices are designed to be compliant with rules and regulations in locations they are sold and will be labeled as required. Local language translations are available at the following website: <https://www.ia.omron.com>. Any changes or modifications to Omron equipment, not expressly approved by Omron, could void the user's authority to operate the equipment.

LED Compliance Statement

Classified as "EXEMPT RISK GROUP" according to IEC 62471:2006 and EN 62471:2008. Pulse duration: Continuous

Laser Devices

Class 2 laser scanners use a low power, visible light diode. As with any very bright light source, such as the sun, the user should avoid staring directly into the light beam. Momentary exposure to a Class 2 laser is not known to be harmful.

The following statement is required to comply with US and international regulations.



Caution: Use of controls or adjustments or performance of procedures other than those specified herein may result in hazardous laser light exposure.

Laser and LED light is emitted from this aperture:

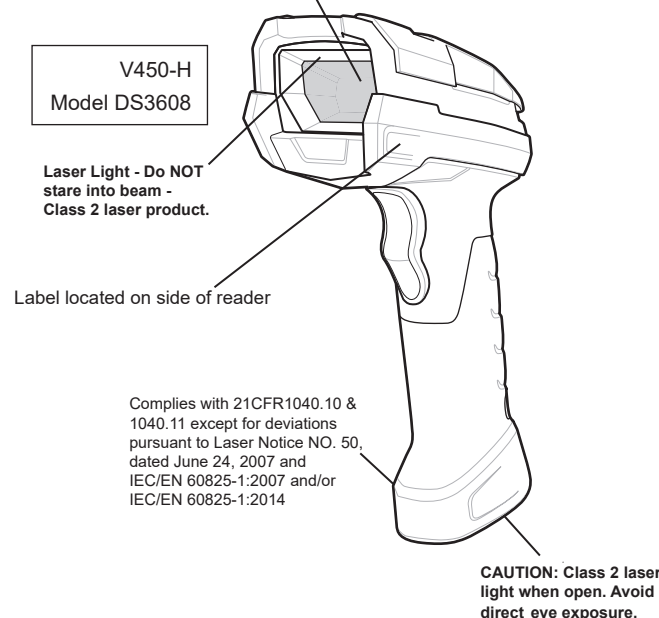

Power Supply

Use ONLY an Omron Microscan approved UL-LISTED ITE (IEC/EN 60950-1, LPS/SELV) power supply with electrical ratings: Output 5 Vdc, min 0.2A, with a maximum ambient temperature of at least 50 degrees C. Use of alternative power supply will invalidate any approvals given to this unit and may be dangerous.

Note: The optional external power supply, P/N V450-AC0-1, is rated for use in a 40 degrees C maximum ambient temperature.

Radio Frequency Interference Requirements - FCC



Tested to comply with FCC Standards FOR HOME OR OFFICE USE. Note: This equipment has been tested and found to comply with the limits for a Class B digital device, pursuant to Part 15 of the FCC rules. These limits are designed to provide reasonable protection against harmful interference in a residential installation. This equipment generates, uses and can radiate radio frequency energy and, if not installed and used in accordance with the instructions, may cause harmful interference to radio communications. However there is no guarantee that interference will not occur in a particular installation. If this equipment does cause harmful interference to radio or television reception, which can be determined by turning the equipment off and on, the user is encouraged to try to correct the interference by one or more of the following measures:

- Reorient or relocate the receiving antenna
- Increase the separation between the equipment and receiver
- Connect the equipment into an outlet on a circuit different from that to which the receiver is connected
- Consult the dealer or an experienced radio/TV technician for help.

Radio Frequency Interference Requirements - Canada

CAN ICES-3 (B)/NMB-3(B).

CE Marking and European Economic Area (EEA)

Statement of Compliance

Omron hereby declares that this device is in compliance with all applicable Directives, 2014/30/EU, 2014/35/EU and 2011/65/EU. The full text of the EU Declaration of Conformity is available at the following internet address: <http://www.ia.omron.com>.

Other Countries

Japan (VCCI) - Voluntary Control Council for Interference Class B ITE

この装置は、情報処理装置等電波障害自主規制協議会（VCCI）の基準に基づくクラスB情報技術装置です。この装置は、家庭環境で使用することを目的としていますが、この装置がラジオやテレビジョン受信機に近接して使用されると、受信障害を引き起こすことがあります。取扱説明書に従って正しい取り扱いをして下さい。

Korea Warning Statement for Class B ITE

기종별	사용자 안내
B급 기기 (가정용 방송통신기기)	이 기기는 가정용(B급)으로 전자파적합등록을 한 기기로서 주로 가정에서 사용하는 것을 목적으로 하며, 모든 지역에서 사용할 수 있습니다.

Chile

Este equipo cumple con la Resolución No 403 de 2008, de la Subsecretaría de telecomunicaciones, relativa a radiación electromagnética.

China

通过访问以下网址可下载当地语言支持的产品说明书
www.ia.omron.com



Thailand

เครื่องโทรคมนาคมและอุปกรณ์นี้ มีความสอดคล้องตามข้อกำหนดของ กทท.

Ukraine

Дане обладнання відповідає вимогам технічного регламенту №1057, № 2008 на обмеження щодо використання деяких небезпечних речовин в електричних та електронних пристроях.

China RoHS

This table was created to comply with China RoHS requirements.

部件名称 (Parts)	有害物质					
	铅 (Pb)	汞 (Hg)	镉 (Cd)	六价铬 (Cr(VI))	多溴联苯 (PBB)	多溴二苯醚 (PBDE)
金属部件 (Metal Parts)	X	O	O	O	O	O
电路模块 (Circuit Modules)	X	O	O	O	O	O
电缆及电缆组件 (Cables and Cable Assemblies)	O	O	O	O	O	O
塑料和聚合物部件 (Plastic and Polymeric Parts)	O	O	O	O	O	O
光学和光学组件 (Optics and Optical Components)	X	O	O	O	O	O
电池 (Batteries)	O	O	O	O	O	O

本表格依据SJ/T 11364 的规定编制。

O: 表示该有害物质在该部件所有均质材料中的含量均在 SJ/T 11364—2014 规定的限量要求以下。
X: 表示该有害物质至少在该部件的某一均质材料中的含量超出 SJ/T 11364—2014 规定的限量要求。(企业可在此处, 根据实际情况对上表中打“X”的技术原因进行进一步说明。)

This table was created to comply with China RoHS requirements.

OMRON

MICROSCAN

Omron Microscan Systems, Inc.
ia.omron.com
All rights reserved. The information contained herein is proprietary and is provided solely for the purpose of allowing customers to operate and/or service Omron Microscan-manufactured equipment and is not to be released, reproduced, or used for any other purpose without written permission of Omron Microscan.

© 2020 Omron Microscan Systems, Inc.



P/N 83-9111022-02 Rev A



V450-H Wired Handheld DPM Reader