



Displacement Sensor Technical Guide (The Basics)

This guide provides an easy-to-understand explanation about the basics of displacement sensors that you should know so that you can make the smooth introduction for all sorts of inspections and measurements.

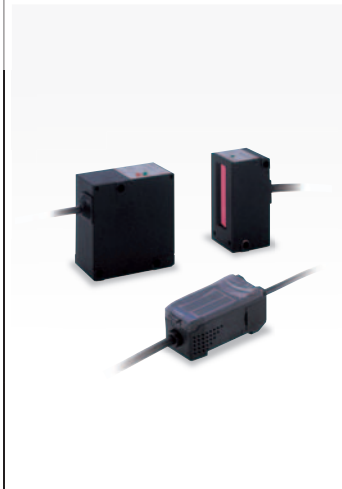

Table of contents

Displacement Sensor System

The Basics of Laser Displacement Sensor

The Basics of White Light Confocal Displacement Sensor

The Basics of Measurement Sensor

The Basics of Proximity Displacement Sensor

The Basics of Contact Displacement Sensor

Resolution and Linearity

Advantage of White Light Confocal Displacement Sensor:

Angle Characteristics

Advantage of White Light Confocal Displacement Sensor:

Measurement Error between different materials

Advantage of White Light Confocal Displacement Sensor:

Resolution in Tracing

Advantage of White Light Confocal Displacement Sensor:

Direction-free

Displacement Sensor System

The Omron's proprietary displacement sensor principles are illustrated below.

What is "Displacement"? What is a Displacement Sensor?

● What is "Displacement"?

"Displacement" is to measure a quantitative state of target object. It is to quantify various conditions of target object (hereinafter called workpiece).

Displacement

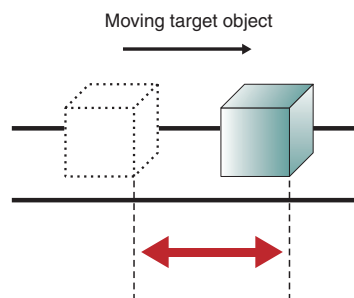

● What is a "Displacement Sensor"?

Displacement sensor quantifies conditions of workpiece for measurement. It measures dimensions of workpiece such as height, width and thickness by determining the distance travelled by workpiece or displacement. Methods to determine the displacement include a non-contact method that uses laser or magnetism and a contact method that uses dial gauge or differential transformer.

Examples of workpiece measured by displacement sensor

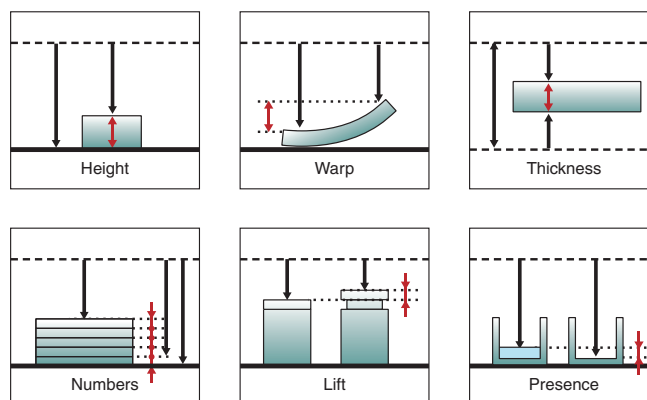

Type of Displacement Sensors

Omron offers a variety of displacement sensors and is able to select and suggest a sensor according to the customer's needs. Here are Omron's main displacement sensors.

Optical laser displacement sensor calculates the travel of workpiece from changes in incident angle of reflective light.

Eddy current magnetic displacement sensor calculates the travel of workpiece from changes in oscillation amplitude using high-frequency magnetic field. Differential transformer contact sensor calculates the travel of workpiece from the positional relations between inner coil and the core which moves in proportion to the probe.

Measurement sensor calculates the position and dimensions of workpiece from the state in which a workpiece interrupts a band of laser beam between emitter and receiver.

White light confocal displacement sensor calculates the distance between workpiece and sensor head by determining the reflective light color (i.e., wavelength) on workpiece.

				Determination	Simple measurement	Measurement	High-precision measurement
Measurement sensor	Optical	Reflection (Displacement)	1 dimension	E2NC-S (CMOS•Triangulation)	ZX/ZX0/ZX1/ZX2 (PSD/CMOS•Triangulation)	ZS (CMOS•Triangulation)	ZW/ZW5/ZW7 (CMOS•Confocal)
			2 dimension	—	—	ZG2 (2D CMOS)	—
	Through-beam (Measurement)		—	ZX-LT (PD: Light level)	ZX-GT (CCD)	3Z4L (Scan)	
	Eddy current/Proximity type		E2C-ED	ZX-E	—	—	
	Contact type		E9NC	ZX-T	—	—	

- Applications given in this document are for reference only. Please make sure of the safety of equipment and machines before use.
- Company names and product names given in this document are the trademark of company or registered trademark.
- Product photographs and illustrations given in this document include sample images and may be different from real ones.

Characteristics and Positioning of Each Sensor

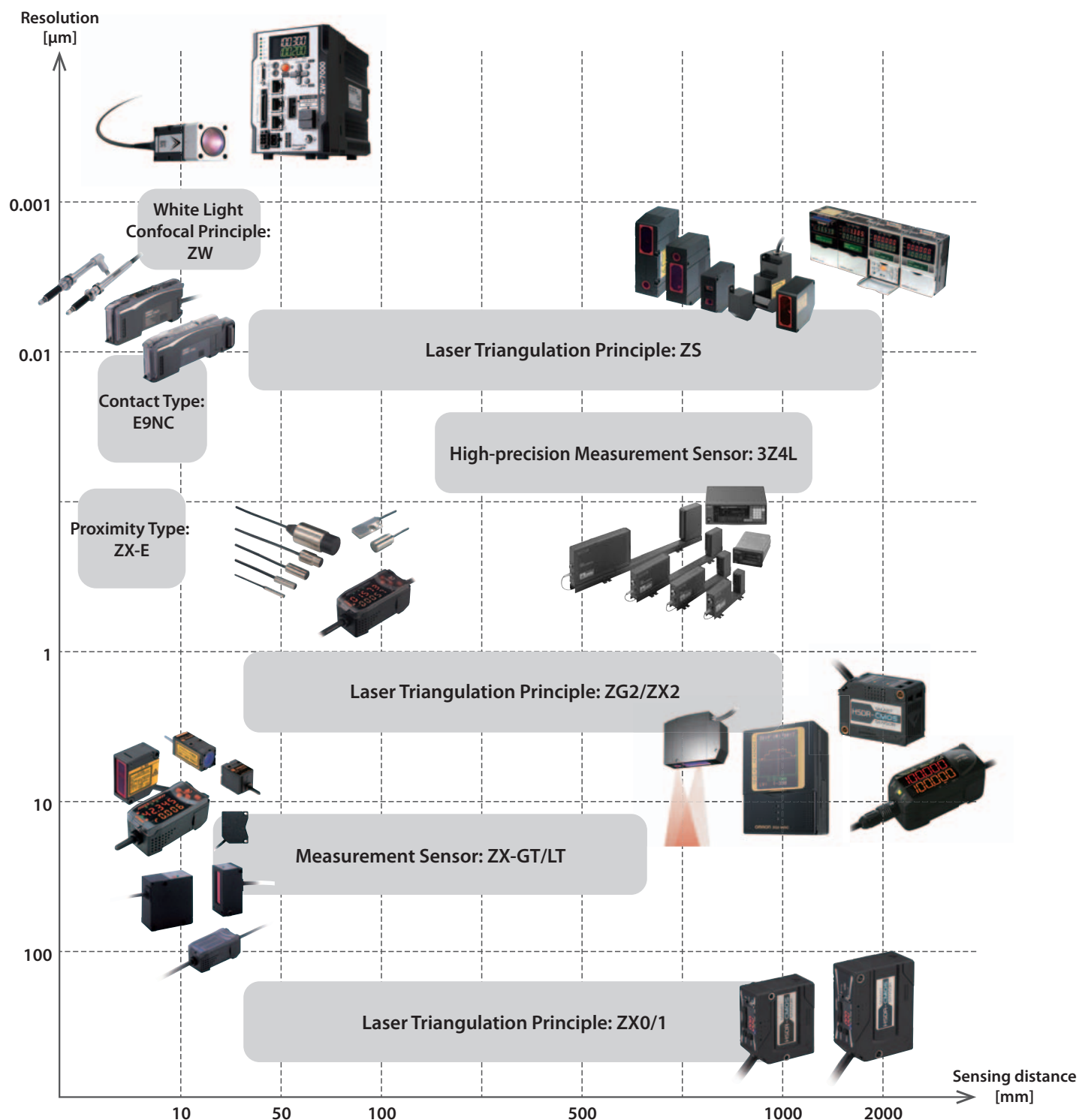

* This specification is a reference value of main models. For details, please refer to a product catalog or datasheet.

- Applications given in this document are for reference only. Please make sure of the safety of equipment and machines before use.
- Company names and product names given in this document are the trademark of company or registered trademark.
- Product photographs and illustrations given in this document include sample images and may be different from real ones.

The Basics of Laser Displacement Sensor

The laser triangulation principle is explained below.

Mechanism to determine the distance

● Basic principle of laser displacement sensor (Triangulation principle)

Laser displacement sensor measures the displacement or distance travelled by workpiece based on the triangulation principle. Laser beam emitted from the light source reflects on the workpiece and then converges on the light-receiving element. If the height of workpiece changes, the position of laser spot received on the light-receiving element changes accordingly. Therefore, by detecting the position of laser spot, the displacement of the workpiece can be determined.

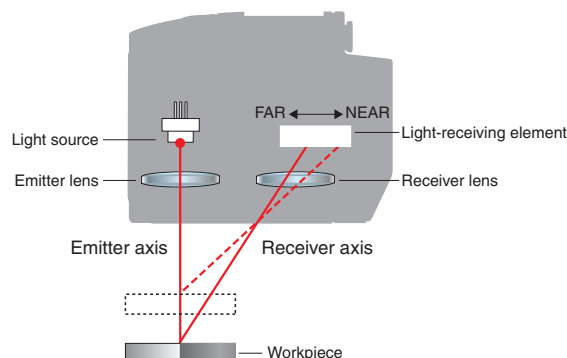

keyword Light-receiving element

Light-receiving element refers to an element that recognizes light (laser beam) as signals. Light-receiving element are classified into PSD (Position Sensitive Device), CCD (Charge Coupled Device) and CMOS (Complementary Metal Oxide Semiconductor).

Point

Value measured by laser displacement sensor is not illumination (brightness) but the position where light is illuminated. Therefore, if the distance between sensor and workpiece varies and then incident level changes accordingly (i.e., an excess or short of light level occurs), the displacement can be determined.

● Difference in precision between laser displacement sensors

Triangulation principle of laser displacement sensor is mainly classified into PSD method and CMOS method. Precision varies between light-receiving elements.

○ PSD method

When incident level decreases, light signal noise increases because light-intercepting gain becomes bigger, which leads to a lower resolution. PSD is one dimensional light-receiving element, so the center of gravity of all the light received represent a peak position. In case there are color irregularities and variations on the surface of workpiece, position may shift from a true peak position, thus causing a measurement error.

PSD method

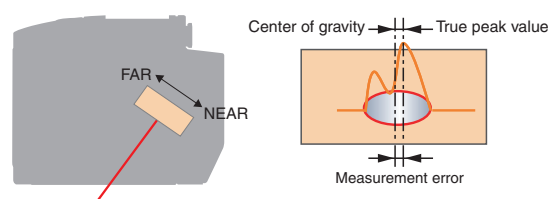

○ CMOS method

The CMOS method can increase incident level, if it goes down, by extending light emitting time. Consequently, light signal noise level remains the same and the resolution stays at almost the same level. CMOS is two dimensional light-receiving element, which can detect light level on each pixel. In case there are color irregularities and variations on the surface of workpiece, a true peak position can be determined.

CMOS method

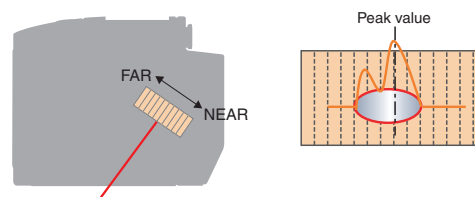

- Applications given in this document are for reference only. Please make sure of the safety of equipment and machines before use.
- Company names and product names given in this document are the trademark of company or registered trademark.
- Product photographs and illustrations given in this document include sample images and may be different from real ones.

The Basics of White Light Confocal Displacement Sensor

The white light confocal principle is described below.

Mechanism to determine the distance

● White light confocal principle

White light emitted from LED is separated by the color or wavelength through a special lens module built in the sensor head and then each of the colors focuses on a different position. As a result, the color of light that is converged according to the height of workpiece returns to the sensor, which allows a distance between the sensor head and the workpiece to be calculated from the color of the reflective light. The sensor head contains a special set of lenses that separates white light by the color whereas the controller has the white LED light source and the spectroscopy and processor that convert the color of reflective light into the distance.

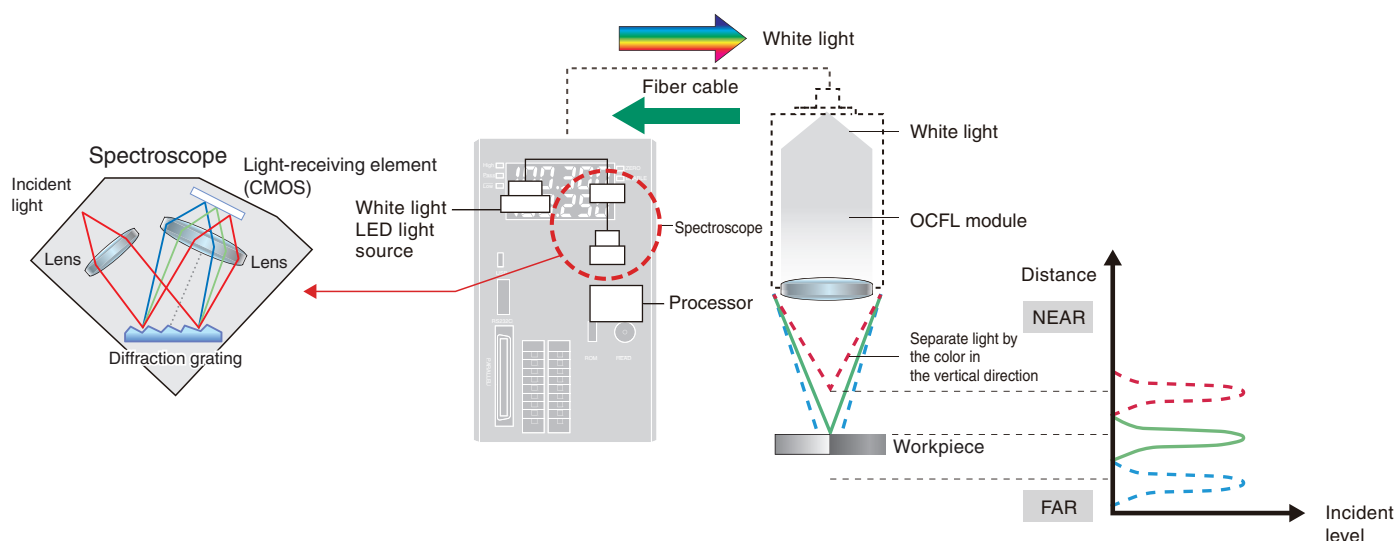

(Supplement) Changes of reflective light according to the height of workpiece

If the distance between workpiece and sensor changes, the color varies as follows.

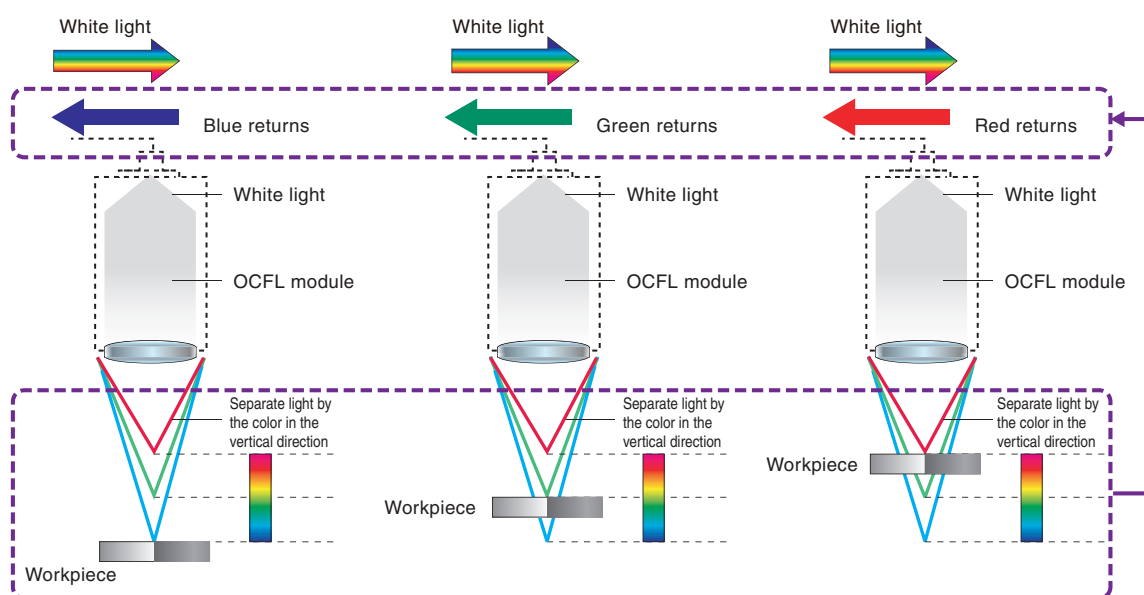

- Applications given in this document are for reference only. Please make sure of the safety of equipment and machines before use.
- Company names and product names given in this document are the trademark of company or registered trademark.
- Product photographs and illustrations given in this document include sample images and may be different from real ones.

The Basics of Measurement Sensor

How a measurement sensor works is explained below.

Mechanism to determine the dimensions

● Measurement sensor

Measurement sensor calculates the position and dimensions of workpiece from the state in which a workpiece interrupts a band of laser beam between emitter and receiver. There are three kinds of detection principles.

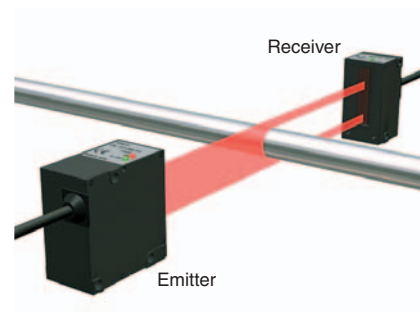

○ Light intensity determination method

A parallel laser beam is emitted from emitter to receiver and is condensed on a light-receiving element through lens of the receiver. If there is a workpiece between the emitter and receiver, the incident level declines. Resultantly, the change in the width of workpiece comes out as the change in linear output.

Application	-Determine outer diameter -Detect edge position (opaque object only)
Applicable model	ZX-LT

Light intensity determination method

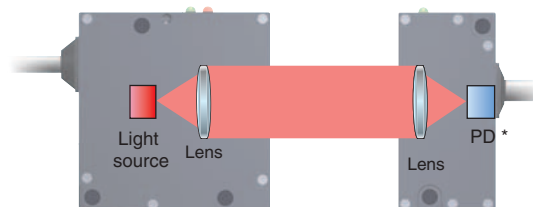

* PD: Photo Diode

○ CCD method

A one-dimensional CCD image sensor is used in the receiver to recognize the position of workpiece. Using digital processor, this method enables more accurate measurements than the light intensity determination method.

Application	-Determine outer diameter -Detect edge position (including transparent object) -Inspect pin pitch -Detect bar position
Applicable model	ZX-GT

CCD method

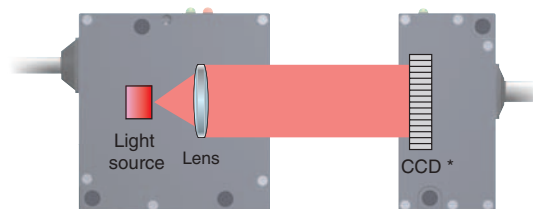

* CCD: Charge Coupled Device

○ Laser scanning method

The sensor performs a measurement by scanning a workpiece with a small diameter laser beam from the emitter. The width of workpiece is calculated from the duration in which the workpiece interrupts the beam and then the outer diameter is determined.

Application	-Determine outer diameter -Detect edge position (including transparent object) -Inspect pin pitch
Applicable model	3Z4L V3

Laser scanning method

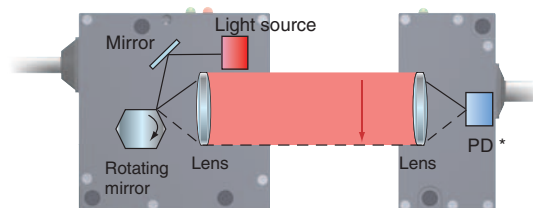

* PD: Photo Diode

• Applications given in this document are for reference only. Please make sure of the safety of equipment and machines before use.
 • Company names and product names given in this document are the trademark of company or registered trademark.
 • Product photographs and illustrations given in this document include sample images and may be different from real ones.

The Basics of Proximity Displacement Sensor

How a proximity sensor works is explained below.

Mechanism to determine the distance

● Basic principle of proximity (magnetic) displacement sensor

Proximity sensor measures the displacement or distance travelled by workpiece by changes in oscillation amplitude. As the distance between workpiece (i.e. metal) and sensor head comes near, eddy current becomes stronger, resulting in a smaller oscillation amplitude of the oscillator. In contrast, as the distance between workpiece and sensor head becomes far apart, eddy current gets weaker, which leads to a larger amplitude. In accordance with changes in the position of workpiece or metal, the oscillation amplitude varies. So the displacement can be determined by detecting the amplitude.

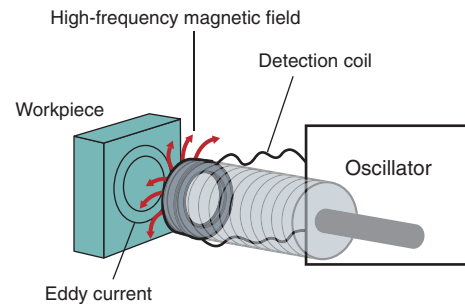

Point
 Workpiece refers to a metal. In case of magnetic metal, sensitivity becomes higher, thus resulting in higher precision.

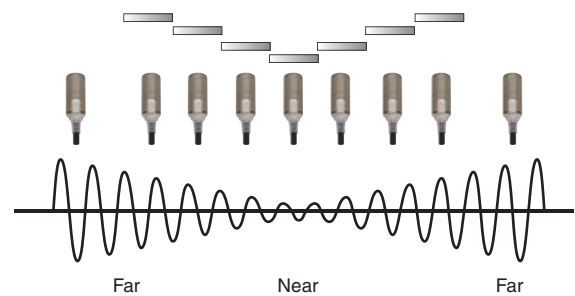

The Basics of Contact Displacement Sensor

How a contact displacement sensor works is explained below.

Mechanism to determine the distance

● Basic principle of contact displacement sensor (Differential transformer method)

Contact displacement sensor measures the displacement of workpiece based on differential displacement sensor method.

When a sensor head comes in contact with workpiece, a movable core is pressed in and the center of core moves away from the center of coil, resulting in a positional gap. When both ends of the connected two coils are excited with AC current, the impedance of both coils changes according to the travel from the center of the coil to the center of the core (i.e. positional gap). This gap or displacement is output linearly as the differential voltage of the coils, and therefore the displacement of the workpiece can be determined by detecting this differential voltage.

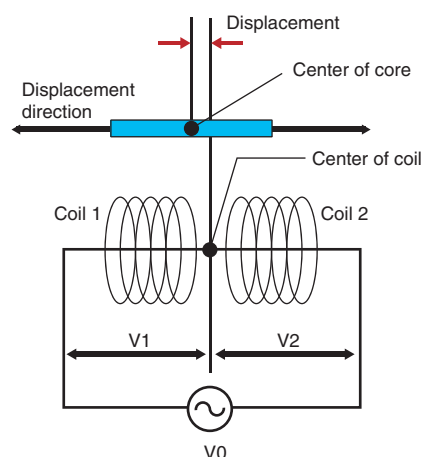

$$Y = \frac{V1 - V2}{V0} = 1 - 2 \frac{V2}{V0}$$

keyword Impedance

The apparent opposition in an electrical circuit to the flow of an alternating current

● Basic principle of contact displacement sensor (Magnetic sensing method)

Metal material inside the sensor is magnetized to generate magnetic scale with north and south poles alternately positioned at a fine pitch. Indentation or travel is measured by detecting which part of magnetic scale reacts when a spindle is pressed in. As magnetic metal is used in the operating principle, the contact sensor features superior environmental resistance against oil and condensation and no tracking errors.

IP67 Degree of Protection * and Magnetic Sensing Method

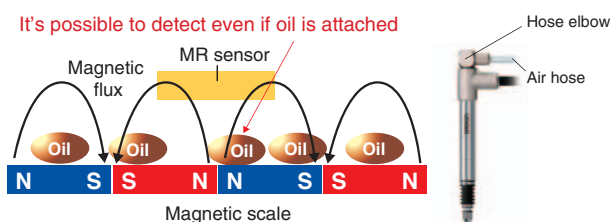

* It applies only when a right-angle type hose elbow and air hose are attached.

Ball spline mechanism

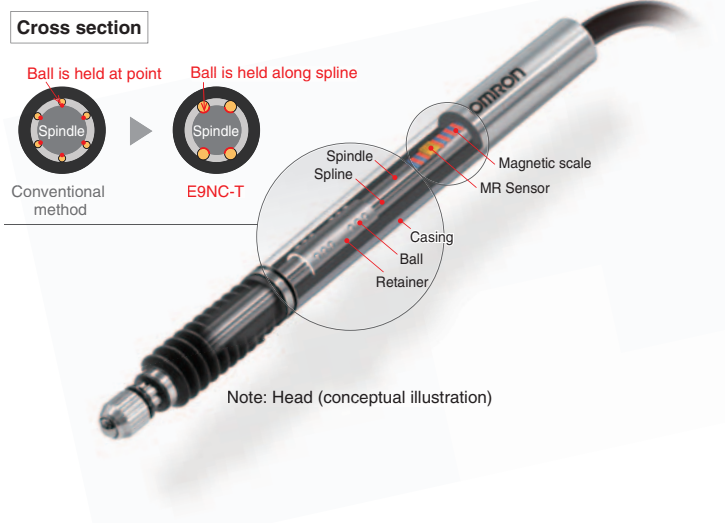

Point

Ball spline mechanism provides a large area where a ball and spindle are in contact, allowing a spindle to make linear motion. This mechanism prevents wobbles and deviation to a circuit.

- Applications given in this document are for reference only. Please make sure of the safety of equipment and machines before use.
- Company names and product names given in this document are the trademark of company or registered trademark.
- Product photographs and illustrations given in this document include sample images and may be different from real ones.

Resolution and Linearity

The basics of resolution and linearity are explained as follows.

What is Resolution? Static Resolution and Resolution in Tracing

● Resolution

When the linear output of static workpiece and sensor is enlarged, there are minute fluctuations or variations caused by inner noise of sensor. This fluctuation width is called resolution. The smaller width means the higher resolution. Resolution is an indicator of the repeatability in positioning workpiece, not an indicator of the distance accuracy.

Fluctuations (variations) of linear output

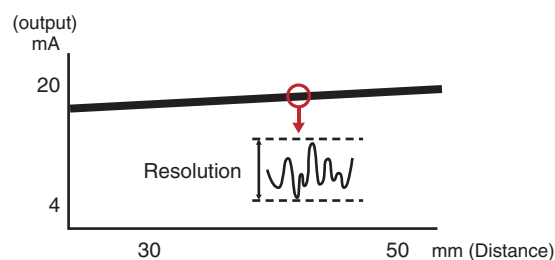

keyword Linear output (analog output)

Output that is produced as a result of converting measurement outcome into electric current or voltage.

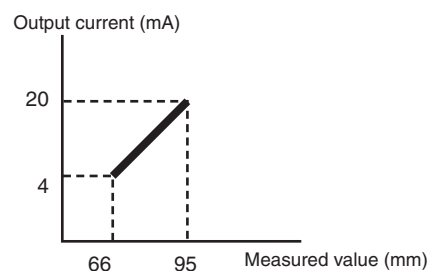

● Static resolution and resolution in tracing

Resolution is classified into static resolution and resolution in tracing.

Static resolution constitutes a fluctuation width output of static workpiece or sensor. In contrast, resolution in tracing represents a fluctuation width output of a flat object or sensor itself in motion.

○ Static resolution

Static resolution arises when a fluctuation is caused largely by inner noise of sensor and controller.

○ Resolution in tracing

Resolution in tracing arises when a fluctuation occurs on the surface of measuring workpiece during the transfer.

Resolution in tracing becomes lower in the measurement of workpiece of which surface is uniform and smooth such as mirror and glass and its measurement outcome is close to the static resolution. In contrast, the resolution in tracing becomes lower when measuring coarse surface (e.g., diffuse-reflection workpiece) and workpiece which fluctuates the reflection amount of laser beam (e.g., absorbing workpiece). Depending on workpiece, resolution in tracing can be 10 times lower than static resolution.

Resolution and Linearity

Relations between travel speed and resolution

Resolution in tracing varies with the travel speed of workpiece.

The higher the travel speed is, the better the resolution in tracing becomes.

This is because the averaging effect becomes higher as the travel distance covered per unit of time becomes longer.

Point

Please take note of the relations between the sampling period of sensor and the travel speed of workpiece in case of measuring a minute profile of the surface.

● Relations between resolution in tracing and sampling period

The distance travelled (d (m)) when a workpiece is moved at the travel speed (v (m/s)) during the sampling period (t (s)) is calculated as follows; $d = vt$ (m)

For example, the sampling period of sensor is $500 \mu\text{s}$ and the travel speed of workpiece is 50 mm/s .

$$d = 50 \times 0.5 = 25 \mu\text{m}$$

The travel distance is $25 \mu\text{m}$ during the sampling period.

If a convex part shown in the right figure is $25 \mu\text{m}$ wide, whether to be able to measure the convex part or not is dependent on the sampling timing. Therefore, in case of measuring a minute profile, it is important to observe how many times the target profile can be measured from the perspective of the relations between the travel speed and the sampling period.

Relations between travel speed and sampling period

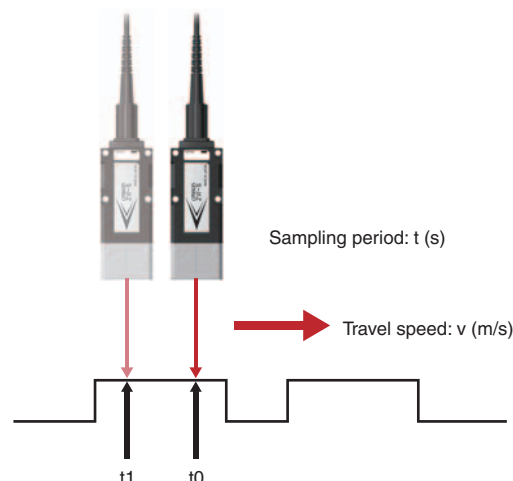

What is Linearity?

Linear output of the displacement sensor is in proportion to the displacement or distance travelled. Although being seemingly linear, actual line is slightly different from ideal line. Linearity indicates the amount of difference or error from ideal line.

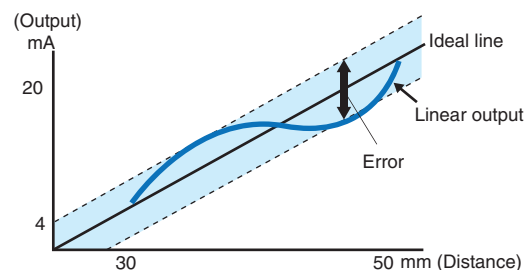

Advantage of White Light Confocal Displacement Sensor: Angle Characteristics

White light confocal principle delivers an excellent angle characteristics, which resolves problems that customers face.

Customer request

There's a request to faithfully measure a workpiece even if it has a curved surface, which is increasing due to improved product design.

Problem 1

A profile of curved surfaces cannot be reproduced.

Conventional laser displacement sensor partially measures curved surfaces and is unable to reproduce the profile.

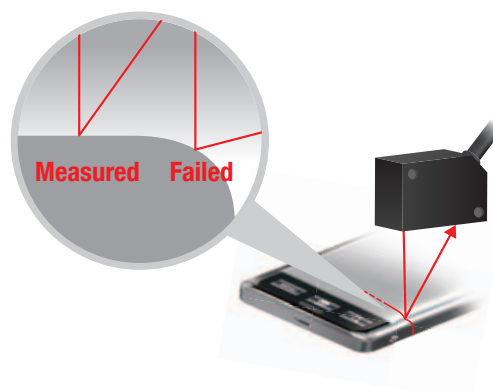

Problem 2

Complex programming is required to measure curved surfaces.

Conventional laser displacement sensor requires both complex programming and mechanical drives to measure curved surfaces.

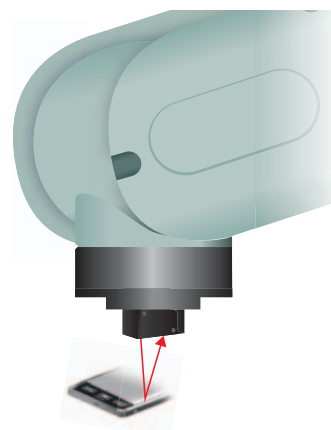

Examples of application that involves measurement of curved surface

<p>Curvature measurement of rolled glass</p>	<p>Profile measurement of silicon</p>	<p>Operation inspection of connecting point of relay</p>	<p>Depth measurement of hole on metal component</p>
<p>Detection is unstable on curved surface of glass</p>	<p>Detection is unstable on silicon applied curved surface</p>	<p>Detection is unstable on curved surface of metal</p>	<p>Detection is unstable on curved surface of metal</p>

- Applications given in this document are for reference only. Please make sure of the safety of equipment and machines before use.
- Company names and product names given in this document are the trademark of company or registered trademark.
- Product photographs and illustrations given in this document include sample images and may be different from real ones.

Advantage of White Light Confocal Displacement Sensor: Angle Characteristics

Advantage of Angle Characteristics

● Comparison of angle characteristics with conventional laser displacement sensor

Conventional laser displacement sensor is unable to detect a curved surface and narrow space outside the angle range of $\pm 5^\circ$ of the top of workpiece whereas white light confocal displacement sensor provides a high precision measurement even for workpiece with an inclination of $\pm 25^\circ$.

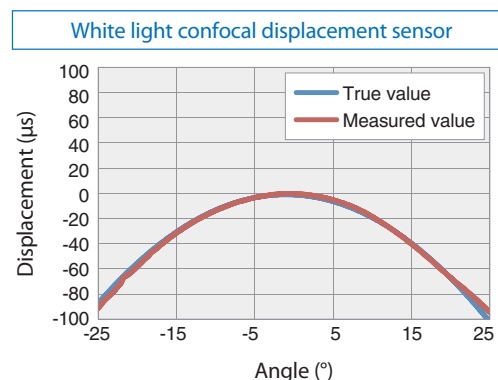
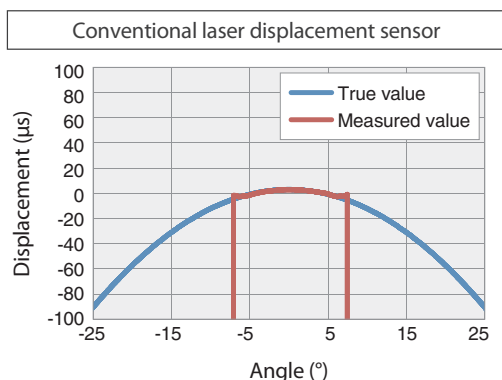

● Reasons for excellent angle characteristics

○ White light confocal principle

A part of the reflective light on a curved surface of workpiece can be captured, which enables a stable measurement.

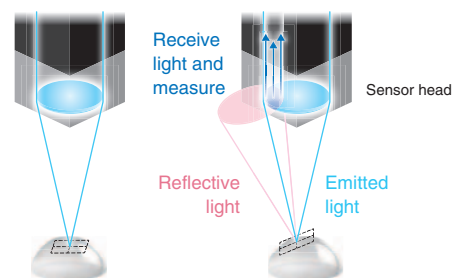

○ Triangulation principle

A laser beam is spotted on workpiece. On glossy surface and surface that causes regular reflection, it is not stable to receive reflective light if a workpiece is positioned incorrectly. Even if the light is received, an error in measurement occurs due to aberration of light-receiving lens.

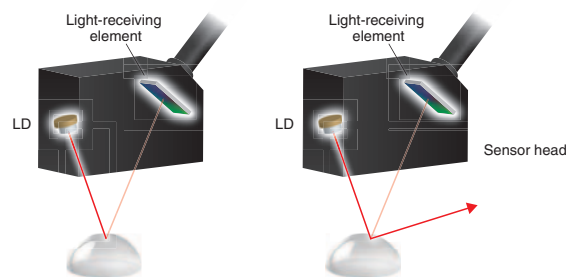

<Influence of lens aberration>

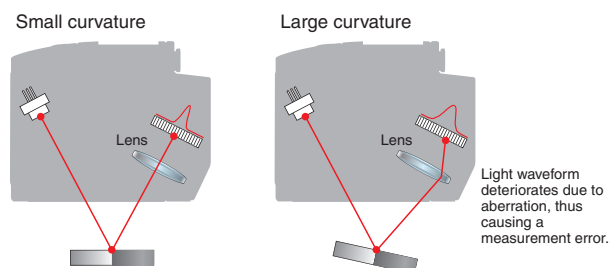

- Applications given in this document are for reference only. Please make sure of the safety of equipment and machines before use.
- Company names and product names given in this document are the trademark of company or registered trademark.
- Product photographs and illustrations given in this document include sample images and may be different from real ones.

Advantage of White Light Confocal Displacement Sensor: Measurement Error between different materials

The white light confocal principle provides an exceptional ability to respond to mixed materials, which resolves problems that customers face.

Customer request

There's a request to faithfully measure workpiece composed of mixed materials.

Problem 1

When measuring a different material, a sensor need to be adjusted to its optimal setting.

On mixed production line where workpiece composed of mixed materials and workpiece that contains different quality of materials are processed, conventional laser displacement sensor has to be adjusted when measuring different materials because the change of materials deteriorates the precision.

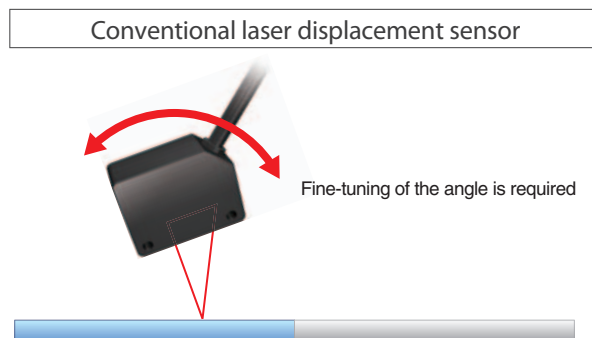

Problem 2

Type of sensors need to be switched for a workpiece.

Conventional displacement laser sensor requires an appropriate sensor head according to a workpiece.

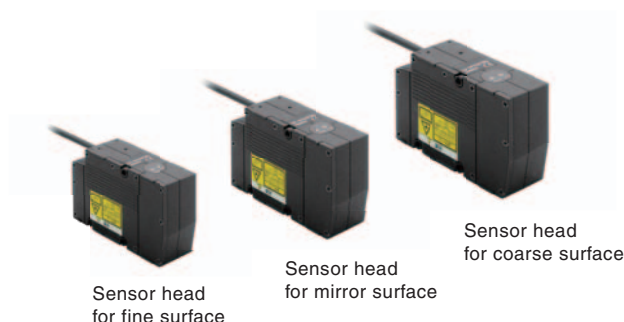

Examples of application subject to measurement errors between different materials.

<p>Profile inspection of friction materials for clutch</p>	<p>Z axis adjustment of chip mounter</p>	<p>Profile measurement of solder on substrate</p>	<p>Assembly measurement of ECU board</p>
<p>Precision is not stable between friction material and metal surface</p>	<p>Precision differs among materials on board</p>	<p>Precision is not stable between solder and sheet</p>	<p>Precision differs among materials on board</p>

- Applications given in this document are for reference only. Please make sure of the safety of equipment and machines before use.
- Company names and product names given in this document are the trademark of company or registered trademark.
- Product photographs and illustrations given in this document include sample images and may be different from real ones.

Advantage of White Light Confocal Displacement Sensor: Measurement Error between different materials

Advantage against measurement errors between different materials

● Comparison of measurement errors between different materials with conventional laser displacement sensor

Conventional laser displacement sensor required adjustment of setting position and configuration, whereas white light confocal displacement sensor can perform a stable measurement within 1 μm margin of error in linearity even if a workpiece is composed of different materials.

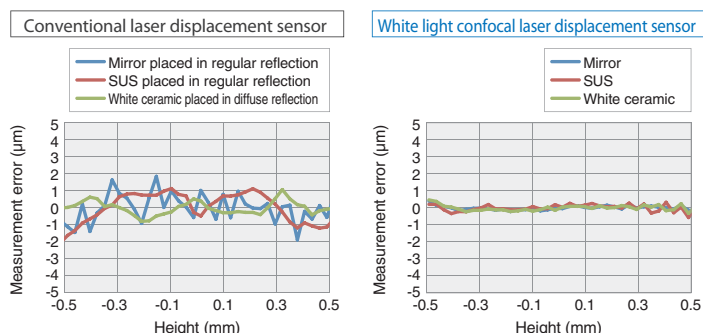

● Reasons for small measurement error between different materials

White light confocal principle

Diffuse-reflection workpiece

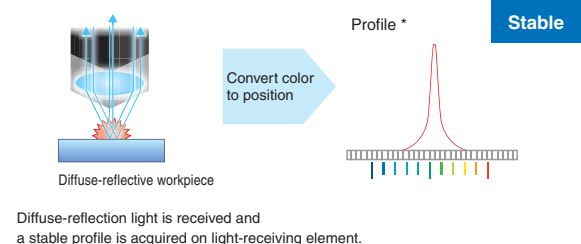

Regular-reflection workpiece

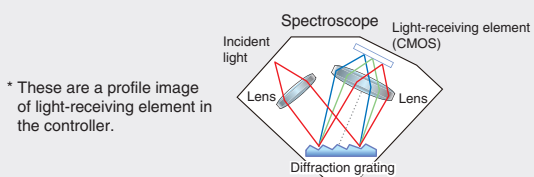
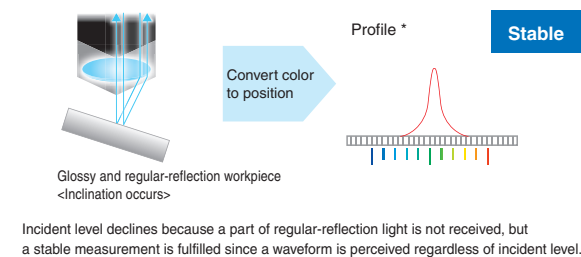
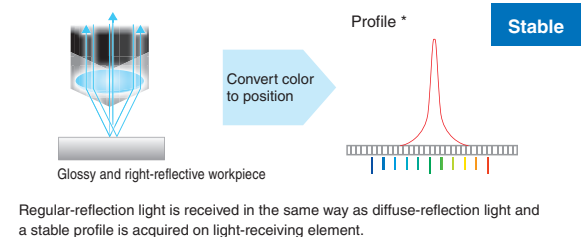

Triangulation principle

Diffuse-reflection workpiece

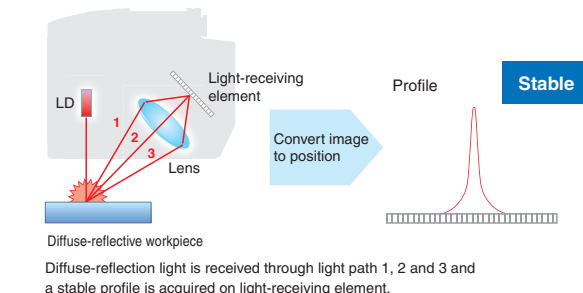

Regular-reflection workpiece

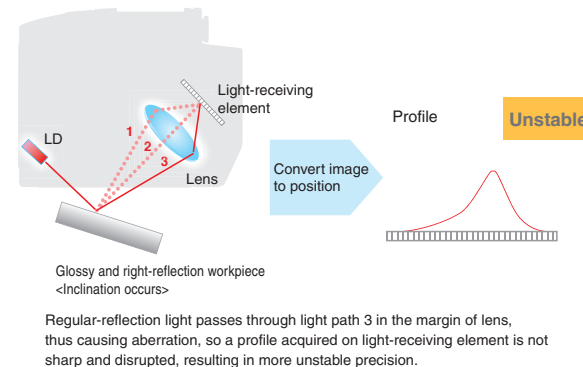
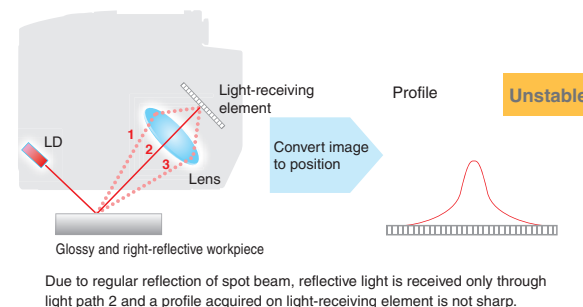

Advantage of White Light Confocal Displacement Sensor: Resolution in Tracing

Exceptional resolution in tracing delivered by the white light confocal principle resolves problems that customers face.

Customer request

There's a request to faithfully measure a workpiece traveling on the line.

Problem 1

Accuracy decreases when a workpiece is measured while being transferred.

Conventional laser displacement sensor is unable to accurately measure a workpiece travelling on the line.

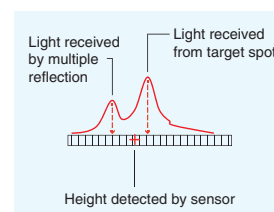
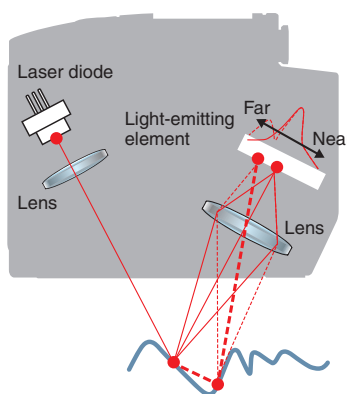
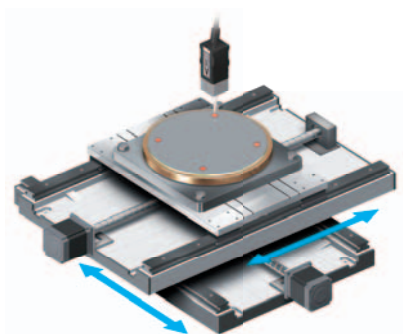

Problem 2

Stability of precision depends on surface materials.

Measured value fluctuates when a conventional displacement sensor measures the same spot of the surface.

Conventional displacement sensor

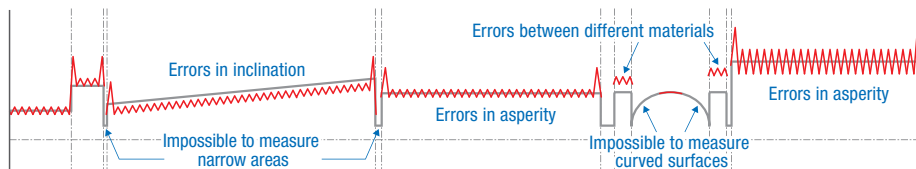

Examples of application that requires high resolution in tracing

Height measurement of wafer

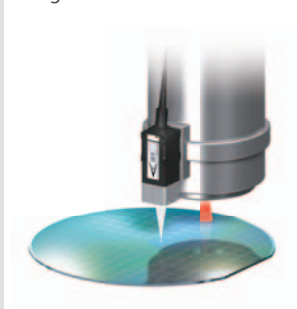

Stability of precision differs among measuring spots of wafer

Eccentricity measurement of motor



Stability of precision depends on the way motor rotates

Level measurement of casing

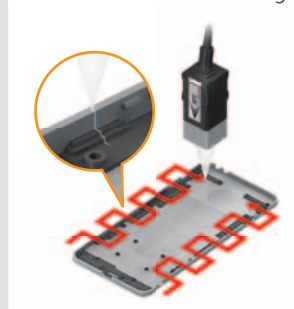

Precision is unstable when measuring workpiece during the transfer

Curvature measurement of rolled glass

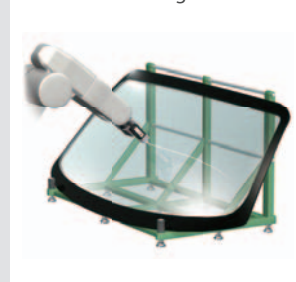

Precision is unstable when measuring workpiece during the transfer

• Applications given in this document are for reference only. Please make sure of the safety of equipment and machines before use.
 • Company names and product names given in this document are the trademark of company or registered trademark.
 • Product photographs and illustrations given in this document include sample images and may be different from real ones.

Advantage of White Light Confocal Displacement Sensor: Resolution in Tracing

Advantage of Resolution in Tracing

● Comparison of resolution in tracing with conventional laser displacement sensor

Due to a low resolution in tracing, conventional laser displacement sensor is less suited for measuring a workpiece being transferred on the line at high-speed. In contrast, white light confocal sensor can measure a workpiece travelling on the line at the margin of errors 5 μm.

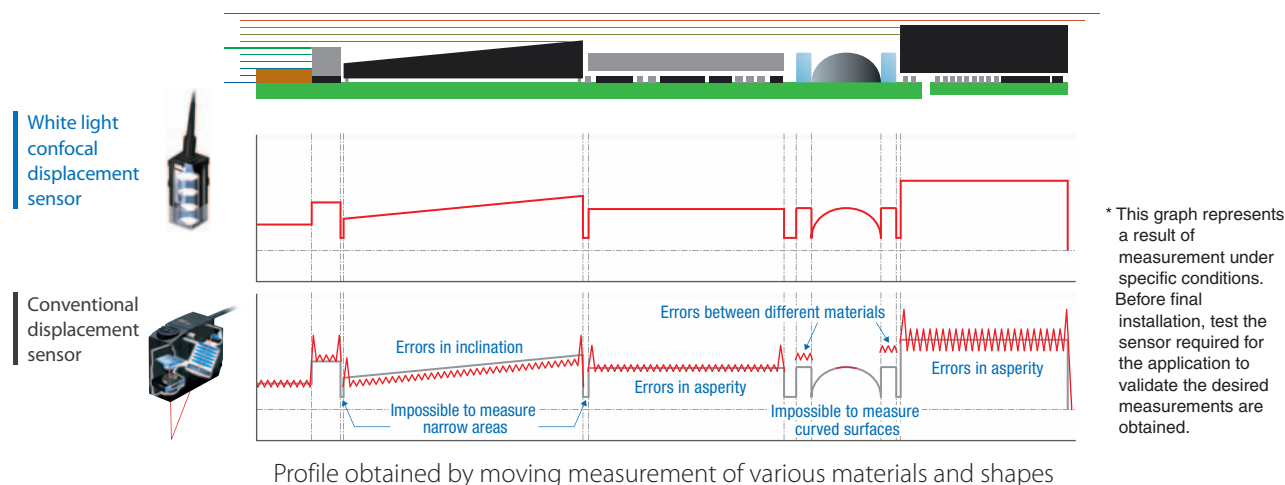

● Reasons for high resolution in tracing

○ White light confocal principle

Reflective light only from the measured point enters into a pinhole. So only a point that needs to be measured can be measured properly.

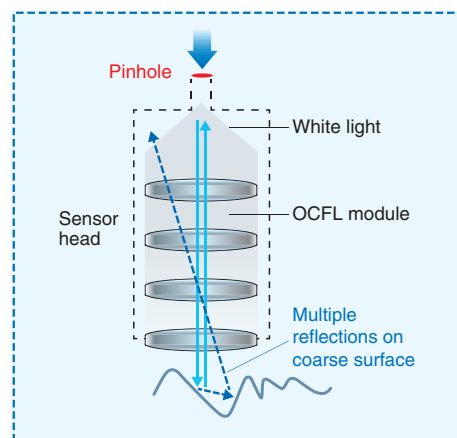

○ Triangulation principle

Reflective light is received by light-receiving element such as CCD and CMOS to generate a conical profile, based on which the position is determined. In this principle, other reflective light from points other than a measured point is also received, which disrupts the profile and fluctuates measured value.

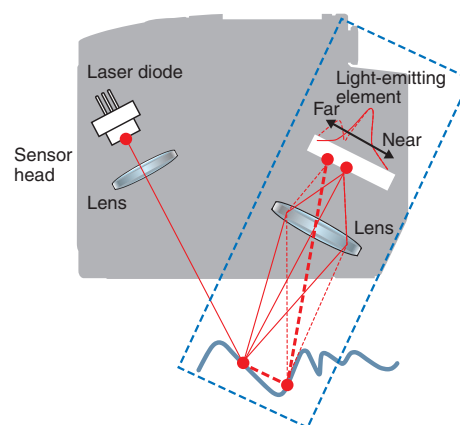
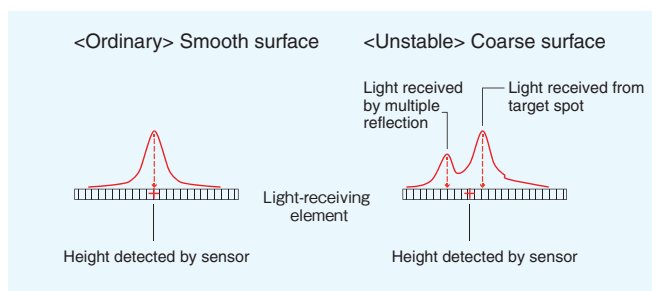

- Applications given in this document are for reference only. Please make sure of the safety of equipment and machines before use.
- Company names and product names given in this document are the trademark of company or registered trademark.
- Product photographs and illustrations given in this document include sample images and may be different from real ones.

Advantage of White Light Confocal Displacement Sensor: Direction-free

Direction-free sensor head based on white light confocal principle contributes to solving problems that customers face.

Customer request

There's a request to measure faithfully regardless of the direction of sensor.

Problem 1

Accuracy depends on the direction of workpiece and sensor.

Conventional laser displacement sensor is affected by the direction of its optical system and accuracy fluctuates with the direction of sensor and the surface condition of workpiece.

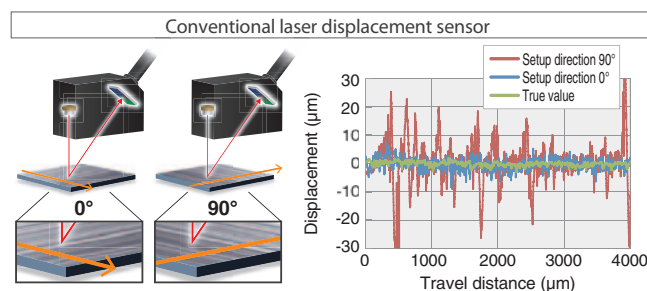

Problem 2

Changing the direction of sensor leads to less efficient work.

To remove errors caused by the directional characteristics, the direction of sensor is controlled, resulting in less efficient work.



Examples of application that requires the control of direction.

<p>Level measurement of button and casing</p>	<p>Level measurement of logo</p>	<p>Height measurement of assembled parts</p>	<p>Gap measurement of electronic chips</p>
<p>Errors occur depending on measurement direction</p>	<p>Errors occur depending on measurement direction</p>	<p>Errors occur depending on measurement direction</p>	<p>Errors occur depending on measurement direction</p>

- Applications given in this document are for reference only. Please make sure of the safety of equipment and machines before use.
- Company names and product names given in this document are the trademark of company or registered trademark.
- Product photographs and illustrations given in this document include sample images and may be different from real ones.

Advantage of White Light Confocal Displacement Sensor: Direction-free

The reason why direction-free white light confocal displacement sensor is beneficial is illustrated below.

Advantage of Direction-free

● Comparison of directional characteristics with conventional laser displacement sensor

Conventional laser displacement sensor is affected by the direction of its optical system, so when a sensor is set up, the direction needs to be carefully considered and also adjusted according to workpiece. In contrast, white light confocal displacement sensor is not influenced by the direction since its emitter and receiver are set along the same axis, allowing for a free layout. Time and effort to control the direction can be reduced, thus contributing to improved takt time.

Conventional laser displacement sensor

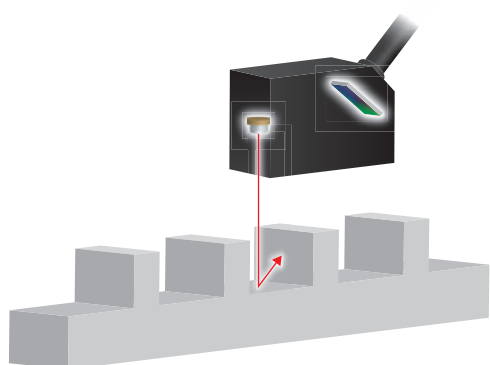

White light confocal displacement sensor

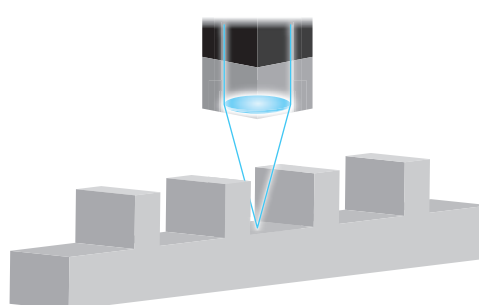

● Reasons for direction-free

○ White light confocal principle

A conical white light beam is emitted and received in a vertical direction, so a stable measurement can be performed regardless of the moving direction.

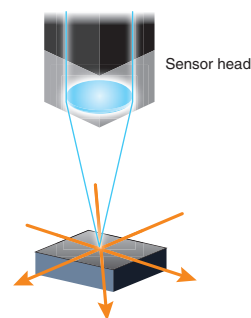

○ Triangulation principle

The limitations of moving direction applies to workpiece and sensor as a reflective point is captured from a diagonally above direction. (Such precaution is indicated in any instruction manual by kind sensor makers.)

If a workpiece moving toward an arrow 2 direction in the right figure is measured, some areas can be hidden from the view of light-receiving element. Consequently, non-measurement state and errors possibly occur.

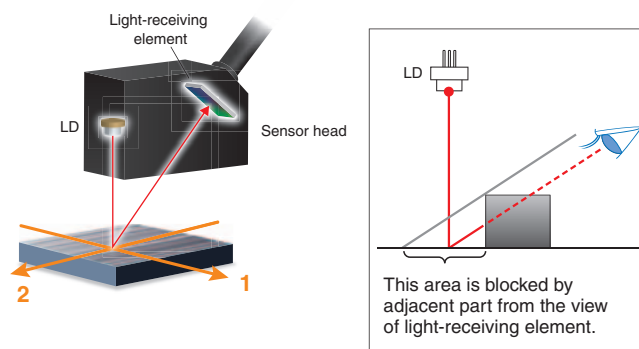

OMRON Corporation Industrial Automation Company

Kyoto, JAPAN

Contact: www.ia.omron.com

Regional Headquarters

OMRON EUROPE B.V.

Wegalaan 67-69, 2132 JD Hoofddorp
The Netherlands
Tel: (31)2356-81-300/Fax: (31)2356-81-388

OMRON ELECTRONICS LLC

2895 Greenspoint Parkway, Suite 200
Hoffman Estates, IL 60169 U.S.A.
Tel: (1) 847-843-7900/Fax: (1) 847-843-7787

OMRON ASIA PACIFIC PTE. LTD.

No. 438A Alexandra Road # 05-05/08 (Lobby 2),
Alexandra Technopark,
Singapore 119967
Tel: (65) 6835-3011/Fax: (65) 6835-2711

OMRON (CHINA) CO., LTD.

Room 2211, Bank of China Tower,
200 Yin Cheng Zhong Road,
PuDong New Area, Shanghai, 200120, China
Tel: (86) 21-5037-2222/Fax: (86) 21-5037-2200

Authorized Distributor:

© OMRON Corporation 2017 All Rights Reserved.
In the interest of product improvement,
specifications are subject to change without notice.

Cat. No. Q257-E1-01

0317