

AMR (Autonomous Mobile Robot)

OL-series

Battery Safety, Unpacking, and Installation Guide

OL-450S2

OL-450S3

NOTE

All rights reserved. No part of this publication may be reproduced, stored in a retrieval system, or transmitted, in any form, or by any means, mechanical, electronic, photocopying, recording, or otherwise, without the prior written permission of OMRON.

No patent liability is assumed with respect to the use of the information contained herein. Moreover, because OMRON is constantly striving to improve its high-quality products, the information contained in this manual is subject to change without notice. Every precaution has been taken in the preparation of this manual. Nevertheless, OMRON assumes no responsibility for errors or omissions. Neither is any liability assumed for damages resulting from the use of the information contained in this publication.

Trademarks

Company names and product names in this document are the trademarks or registered trademarks of their respective companies.

Copyrights

Microsoft product screen shots reprinted with permission from Microsoft Corporation.

Introduction

Thank you for purchasing the OL-series Autonomous Mobile Robot (referred to as AMR in this document).

This guide is OMRON's original instructions describing the unpacking, installation, and safety considerations of the AMR's battery.

This document describes AMR functionality supported with FLOW v5.3.

This guide does not provide all AMR details, specifications, installation, operation, troubleshooting, or maintenance information. This guide is not a substitute for the *AMR (Autonomous Mobile Robot) OL-series User's Manual (Cat. No. M109)*. All personnel that work with the AMR must read and understand the *AMR (Autonomous Mobile Robot) OL-series User's Manual (Cat. No. M109)*.

Please read this guide and make sure you understand the unpacking, installation, and safety considerations of the battery before attempting to unpack or install it.

Keep this guide in a safe place where it will be available for reference for repacking purposes.

To download a digital copy of this manual, use the following QR code or visit the website listed below.



https://robotics.omron.com/browse-documents/?dir_id=37207

Intended Audience

This manual is intended for the following personnel, who must also have knowledge of factory automation (FA) systems and robotic control methods.

- Personnel in charge of introducing FA systems.
- Personnel in charge of designing FA systems.
- Personnel in charge of installing and maintaining FA systems.
- Personnel in charge of managing FA systems and facilities.

It is the end-user's responsibility to ensure that all personnel who will work with or around AMRs have attended an appropriate training and have a working knowledge of the system. The user must provide the necessary additional training for all personnel who will be working with the system.

As described in this document, you should allow only skilled persons or instructed persons to do certain procedures. Skilled persons have technical knowledge or sufficient experience to enable them to avoid either electrical or mechanical dangers. Instructed persons are adequately advised or supervised by skilled persons to enable them to avoid either electrical or mechanical dangers.

All personnel must observe industry-prescribed safety practices during the installation, operation, and testing of all electrically-powered equipment.

Before working with the AMR, every person must confirm that they:

- Have the necessary qualifications and training for normal, abnormal, and emergency situations.
- Have access to this document and other safety documentation.
- Have read and understand the related documentation.
- Have agreed work in the manner specified by the documentation.

Units

All units are metric unless otherwise noted.

Distances are provided in mm unless otherwise noted.

Manual Information

Page Structure

The following page structure is used in this manual.

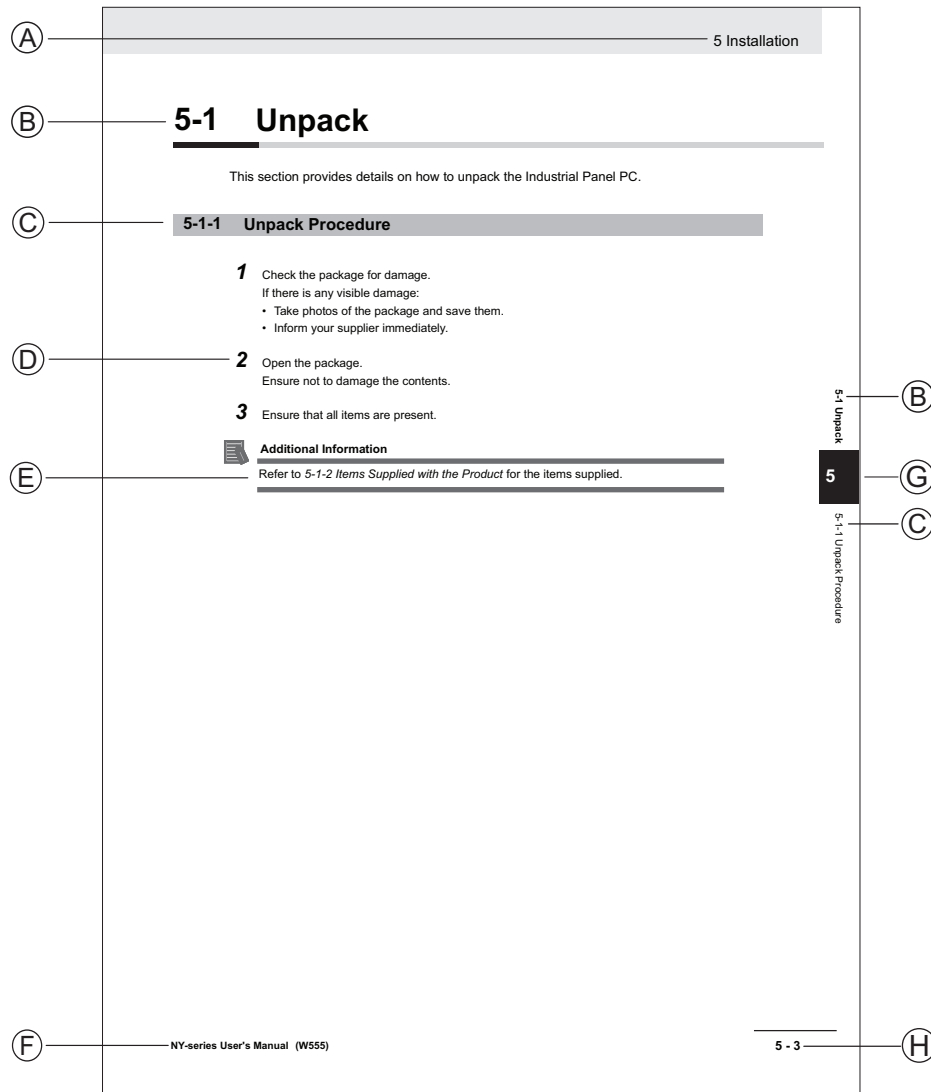

Note: This illustration is provided as a sample. It will not literally appear in this manual.

Item	Explanation	Item	Explanation
A	Level 1 heading	E	Special Information
B	Level 2 heading	F	Manual name
C	Level 3 heading	G	Page tab with the number of the main section
D	Step in a procedure	H	Page number

Special Information

Special information in this manual is classified as follows:



Precautions for Safe Use

Precautions on what to do and what not to do to ensure safe usage of the product.



Precautions for Correct Use

Precautions on what to do and what not to do to ensure proper operation and performance.



Additional Information

Additional information to read as required.
This information is provided to increase understanding or make operation easier.



Version Information

Information on differences in specifications and functionality between different versions.

Sections in this Manual

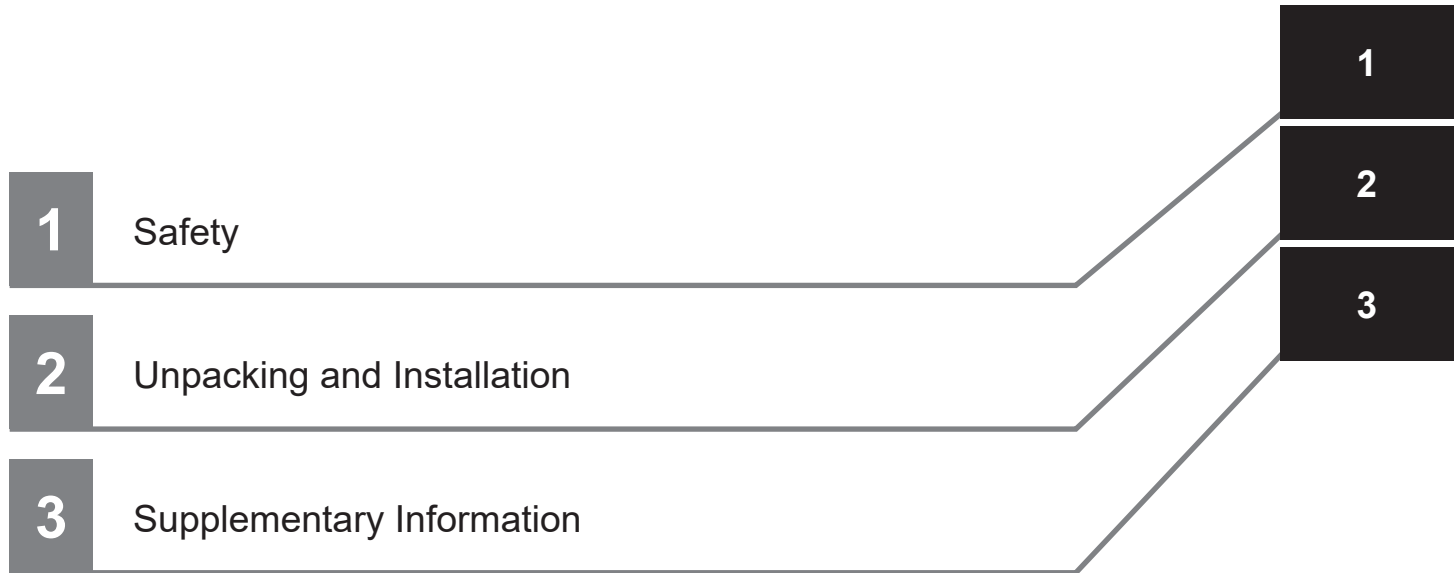

CONTENTS

Introduction	1
Intended Audience	1
Units	2
Manual Information	3
Page Structure	3
Special Information	3
Sections in this Manual	5
Terms and Conditions Agreement.....	8
Warranty and Limitations of Liability	8
Application Considerations	9
Disclaimers	9
Regulations and Standards	11
Directives	11
Standards	11
Regulatory Markings	11
Conformance to KC Certification	11
Related Manuals.....	12
Revision History.....	13

Section 1 Safety

1-1 Safety Precautions.....	1-2
1-1-1 Definition of Precautionary Information	1-2
1-1-2 Symbols	1-2
1-1-3 Dangers.....	1-3
1-1-4 Warnings	1-3
1-1-5 Cautions	1-4
1-2 Precautions for Safe Use	1-6
1-3 Precautions for Correct Use	1-7

Section 2 Unpacking and Installation

2-1 Introduction	2-2
2-2 Unpacking the Battery	2-3
2-3 Battery Installation.....	2-4
2-3-1 Battery Installation and Connection Procedure	2-4

Section 3 Supplementary Information

3-1 AMR Start-up	3-2
3-1-1 AMR Start-up Procedure	3-2
3-2 AMR Shut-down Procedure	3-4
3-3 Charging AMR Battery.....	3-5

3-4	Charging Battery for the First Time	3-6
3-4-1	Charge Using Service Charger	3-6
3-4-2	Automatic Drive Mode Charging	3-7
3-5	Removing and Replacing Skins	3-8
3-5-1	Remove Front Skin	3-8
3-5-2	Replace Front Skin.....	3-9
3-6	Service Charger Specifications	3-10

Terms and Conditions Agreement

Warranty and Limitations of Liability

Warranty

● Exclusive Warranty

Omron's exclusive warranty is that the Products will be free from defects in materials and workmanship for a period of twelve months from the date of sale by Omron (or such other period expressed in writing by Omron). Omron disclaims all other warranties, expressed or implied.

● Limitations

OMRON MAKES NO WARRANTY OR REPRESENTATION, EXPRESS OR IMPLIED, ABOUT NON-INFRINGEMENT, MERCHANTABILITY OR FITNESS FOR A PARTICULAR PURPOSE OF THE PRODUCTS. BUYER ACKNOWLEDGES THAT IT ALONE HAS DETERMINED THAT THE PRODUCTS WILL SUITABLY MEET THE REQUIREMENTS OF THEIR INTENDED USE.

Omron further disclaims all warranties and responsibility of any type for claims or expenses based on infringement by the Products or otherwise of any intellectual property right.

● Buyer Remedy

Omron's sole obligation hereunder shall be, at Omron's election, to (i) replace (in the form originally shipped with Buyer responsible for labor charges for removal or replacement thereof) the non-complying Product, (ii) repair the non-complying Product, or (iii) repay or credit Buyer an amount equal to the purchase price of the non-complying Product; provided that in no event shall Omron be responsible for warranty, repair, indemnity or any other claims or expenses regarding the Products unless Omron's analysis confirms that the Products were properly handled, stored, installed and maintained and not subject to contamination, abuse, misuse or inappropriate modification. Return of any Products by Buyer must be approved in writing by Omron before shipment. Omron Companies shall not be liable for the suitability or unsuitability or the results from the use of Products in combination with any electrical or electronic components, circuits, system assemblies or any other materials or substances or environments. Any advice, recommendations or information given orally or in writing, are not to be construed as an amendment or addition to the above warranty.

See <http://www.omron.com/global/> or contact your Omron representative for published information.

Limitations of Liability

OMRON COMPANIES SHALL NOT BE LIABLE FOR SPECIAL, INDIRECT, INCIDENTAL, OR CONSEQUENTIAL DAMAGES, LOSS OF PROFITS OR PRODUCTION OR COMMERCIAL LOSS IN ANY WAY CONNECTED WITH THE PRODUCTS, WHETHER SUCH CLAIM IS BASED IN CONTRACT, WARRANTY, NEGLIGENCE OR STRICT LIABILITY. Further, in no event shall liability of Omron Companies exceed the individual price of the Product on which liability is asserted.

Application Considerations

Suitability for Use

Omron Companies shall not be responsible for conformity with any standards, codes or regulations which apply to the combination of the Product in the Buyer's application or use of the Product. At Buyer's request, Omron will provide applicable third party certification documents identifying ratings and limitations of use which apply to the Product. This information by itself is not sufficient for a complete determination of the suitability of the Product in combination with the end product, machine, system, or other application or use. Buyer shall be solely responsible for determining appropriateness of the particular Product with respect to Buyer's application, product or system. Buyer shall take application responsibility in all cases.

NEVER USE THE PRODUCT FOR AN APPLICATION INVOLVING SERIOUS RISK TO LIFE OR PROPERTY WITHOUT ENSURING THAT THE SYSTEM AS A WHOLE HAS BEEN DESIGNED TO ADDRESS THE RISKS, AND THAT THE OMRON PRODUCT(S) IS PROPERLY RATED AND INSTALLED FOR THE INTENDED USE WITHIN THE OVERALL EQUIPMENT OR SYSTEM.

Programmable Products

- Omron Companies shall not be responsible for the user's programming of a programmable Product, or any consequence thereof.
- Omron Companies shall not be responsible for the operation of the user accessible operating system (e.g. Windows, Linux), or any consequence thereof.

Disclaimers

Performance Data

Data presented in Omron Company websites, catalogs and other materials is provided as a guide for the user in determining suitability and does not constitute a warranty. It may represent the result of Omron's test conditions, and the user must correlate it to actual application requirements. Actual performance is subject to the Omron's Warranty and Limitations of Liability.

Change in Specifications

Product specifications and accessories may be changed at any time based on improvements and other reasons. It is our practice to change part numbers when published ratings or features are changed, or when significant construction changes are made. However, some specifications of the Product may be changed without any notice. When in doubt, special part numbers may be assigned to fix or establish key specifications for your application. Please consult with your Omron's representative at any time to confirm actual specifications of purchased Product.

Errors and Omissions

Information presented by Omron Companies has been checked and is believed to be accurate; however, no responsibility is assumed for clerical, typographical or proofreading errors or omissions.

Regulations and Standards

Directives

The AMR battery complies with the following Directives.

- 2006/42/EC
Machinery Directive
- 2023/1542/EU
EU Battery Regulation

Standards

The AMR battery conforms to the following standard.

- UN 38.3
Standard for transportation of lithium batteries.

Regulatory Markings

The following regulatory marking appears on the AMR battery.

- CE

Conformance to KC Certification

When you use this product in South Korea, observe the following precautions.

사용자안내문

이 기기는 업무용 환경에서 사용할 목적으로 적합성평가를 받은 기기로서 가정용 환경에서 사용하는 경우 전파간섭의 우려가 있습니다.

This product meets the electromagnetic compatibility requirements for business use.

Related Manuals

Use the following related manuals for reference.

Manual Title	Description
Advanced Robotics Command Language Enterprise Manager Integration Guide (Cat. No. I618)	Describes how to use the Advanced Robotics Command Language (ARCL) a text-based, command line operating language Use ARCL to integrate a fleet of AMRs with an external automation system.
Enterprise Manager 2100 User's Guide (Cat. No. I631)	Describes the installation of an EM2100 appliance, which runs the Fleet Operations Workspace software to manage a fleet of AMRs.
Fleet Operations Workspace Core User's Manual (Cat. No. I635)	Describes Fleet management, MobilePlanner software, the SetNetGo OS, and most of the configuration procedures for an AMR.
MobilePlanner Integrated Help	A repository of Help topics available in the MobilePlanner application. Help topics describe MobilePlanner software, the SetNetGo OS, and most of the configuration procedures for an AMR.
Fleet Operation Workspace Core Integration Toolkit User's Manual (Cat. No. I637)	Contains information that is necessary to use the Integration Toolkit facilitating integration between the AMR, the Fleet Manager and the end user's client application.
Fleet Operations Workspace Core Integration Toolkit MQTT API User's Manual (Cat. No. M107)	Contains information that is necessary to use the Integration Toolkit MQTT API facilitating integration between the AMR, the Fleet Manager and the end user's client application.
Fleet Operations Workspace iQ User's Manual (Cat. No. I665)	Describes functionality and operation of the Fleet Operations Workspace iQ application.
AMR (Autonomous Mobile Robot) OL-series User's Manual (Cat. No. M109)	Describes the functionality, operation, and maintenance of the OL-series AMR.
AMR (Autonomous Mobile Robot) OL-series Safety, Unpacking, and Assembly Guide (Cat. No. M110)	Describes safety, unpacking, and assembly of the OL-series AMR.
AMR (Autonomous Mobile Robot) OL-series Charging Station Safety, Unpacking, and Installation Guide (Cat. No. M111)	Describes safety, unpacking, and installation of the OL-series AMR Charging Station.

Revision History

A manual revision code appears as a suffix to the catalog number on the front and back covers of the manual.

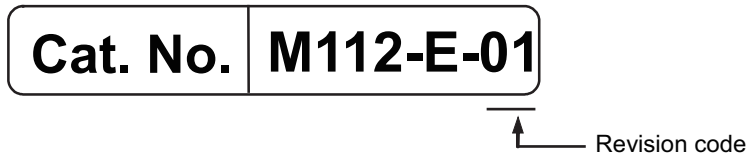

Revision code	Date	Revised content
01	March 2025	Original production

1

Safety

This section provides safety information for the OL-series AMR battery.

1-1	Safety Precautions	1-2
1-1-1	Definition of Precautionary Information	1-2
1-1-2	Symbols.....	1-2
1-1-3	Dangers.....	1-3
1-1-4	Warnings	1-3
1-1-5	Cautions	1-4
1-2	Precautions for Safe Use.....	1-6
1-3	Precautions for Correct Use	1-7



1-1 Safety Precautions

1-1-1 Definition of Precautionary Information







The following notation is used in this manual to provide precautions required to ensure safe usage of the AMR. The safety precautions that are provided are extremely important to safety.

Always read and heed the information provided in all safety precautions.

The following notation is used.

 DANGER	Identifies an imminently hazardous situation which, if not avoided, is likely to result in serious injury, and might result in fatality or severe property damage.
 WARNING	Indicates a potentially hazardous situation which, if not avoided, could result in death or serious injury. Additionally, there may be severe property damage.
 CAUTION	Indicates a potentially hazardous situation which, if not avoided, may result in minor or moderate injury, or property damage.

1-1-2 Symbols

	The circle and slash symbol indicates operations that you must not do. The specific operation is shown in the circle and explained in text. This example indicates prohibiting disassembly.
	The triangle symbol indicates precautions (including warnings). The specific operation is shown in the triangle and explained in text. This example indicates a precaution for electric shock.
	The triangle symbol indicates precautions (including warnings). The specific operation is shown in the triangle and explained in text. This example indicates a general precaution.
	The filled circle symbol indicates operations that you must do. The specific operation is shown in the circle and explained in text. This example shows a general precaution for something that you must do.
	The triangle symbol indicates precautions (including warnings). The specific operation is shown in the triangle and explained in text. This example indicates a precaution for high temperatures.
	The triangle symbol indicates precautions (including warnings). The specific operation is shown in the triangle and explained in text. This example indicates a precaution for laser radiation.

1-1-3 Dangers

DANGER

Do not charge a battery that has not been approved for the OL-series AMR. There is a risk of explosion when charging an incorrect battery. Failure to comply with the above mentioned instruction could result in damage to the Charging Station, battery, and AMR.



1-1-4 Warnings

WARNING

Battery and Charging Station

Do not damage the battery by subjecting it to impacts or shocks. Using a damaged battery can result in fire or other dangerous conditions.



The following actions are strictly prohibited and could result in injury or damage to the equipment.

- Persons with cardiac pacemakers in the AMR charging zone
- Persons with metal implants in the AMR charging zone
- Holding, placing, or allowing objects between the charging coils



Cybersecurity

To maintain the security and reliability of the system, a robust cybersecurity defense program should be implemented, which may include some or all of the following:

Anti-virus protection

- Install the latest commercial-quality anti-virus software on the computer connected to the control system and keep the software and virus definitions up-to-date.
- Scan USB drives or other external storage devices before connecting them to control systems and equipment.

Security measures to prevent unauthorized network access

- Install physical controls so that only authorized personnel can access control systems and equipment.
- Reduce connections to control systems and equipment via networks to prevent access from untrusted devices.
- Install firewalls to block unused communications ports and limit communication between systems. Limit access between control systems and systems from the IT network.
- Control remote access and adopt multifactor authentication to devices with remote access to control systems and equipment.
- Set strong password policies and monitor for compliance frequently.

Data input and output protection

- Backup data and keep the data up-to-date periodically to prepare for data loss.
- Validate backups and retention policies to cope with unintentional modification of input/output data to control systems and equipment.
- Validate the scope of data protection regularly to accommodate changes.
- Check validity of backups by scheduling test restores to ensure successful recovery from incidents.
- Safety design, such as emergency shutdown and fail-soft operations in case of data tampering and incidents.

Additional recommendations

- When using an external network environment to connect to an unauthorized terminal such as a SCADA, HMI or to an unauthorized server may result in network security issues such as spoofing and tampering.
- You must take sufficient measures such as restricting access to the terminal, using a terminal equipped with a secure function, and locking the installation area by yourself.
- When constructing network infrastructure, communication failure may occur due to cable disconnection or the influence of unauthorized network equipment.
- Take adequate measures, such as restricting physical access to network devices, by means such as locking the installation area.
- When using devices equipped with an SD Memory Card, there is a security risk that a third party may acquire, alter, or replace the files and data in the removable media by removing or unmounting the media.
- Please take sufficient measures, such as restricting physical access to the Controller or taking appropriate management measures for removable media, by means of locking and controlling access to the installation area.
- Educate employees to help them identify phishing scams received via email on systems that will connect to the control network.



1-1-5 Cautions

 **CAUTION**

Never connect electric loads directly to the battery bypassing protective circuits.



The Service Charger cables pose a tripping hazard. Place cables in a manner that prevents tripping or isolate the area to prevent people from interacting with cables.



1-2 Precautions for Safe Use

- The AMR must be powered ON in order to charge the battery while at the Charging Station.
- Do not operate the AMR without all skins fastened correctly. Moving parts are exposed when the AMR is in motion.
- Do not touch the AMR charging coils. Coils get very hot during and after charging.

1-3 Precautions for Correct Use

- IATA regulations (UN 3480, PI 965) require that air freight shipped lithium ion batteries not installed in the AMR must be transported at a state of charge not exceeding 30%. To avoid total discharge, fully charge the battery immediately upon receipt. The battery might arrive fully charged if it is not shipped by air freight.
- Implementing methods to circumvent the need for a person to enable the AMR's motor power at start-up is prohibited.
- Always lift the battery using the two handles on top of the battery enclosure.

2

Unpacking and Installation

This section provides unpacking and installation information for the AMR battery.

2-1	Introduction	2-2
2-2	Unpacking the Battery	2-3
2-3	Battery Installation	2-4
2-3-1	Battery Installation and Connection Procedure	2-4

2-1 Introduction

The AMR battery is shipped in a separate box. The general battery unpacking and installation steps are provided below.

Make the following considerations before unpacking the battery.

- The AMR must be unpacked and fully assembled. Refer to *AMR (Autonomous Mobile Robot) OL-series Safety, Unpacking, and Assembly Guide (Cat. No. M110)* and *AMR (Autonomous Mobile Robot) OL-series User's Manual (Cat. No. M109)* for more information.
- The Charging Station must be installed and commissioned prior to charging the battery. Refer to *AMR (Autonomous Mobile Robot) OL-series Charging Station Safety, Unpacking, and Installation Guide (Cat. No. M111)* for more information.
- The battery must be charged soon after it is installed in the AMR.

The general steps for unpacking and installation are provided below.

1. Unpack the battery.
2. Install the battery in the AMR.
3. Charge the battery.

2-2 Unpacking the Battery

The AMR battery is packaged inside a sturdy cardboard box. Follow the procedure below to unpack the battery.

- 1** Open the cardboard box and carefully lift the battery out of the box using the two handles on top of it.
The battery weighs approximately 20 kg.
- 2** Visually inspect the battery for any transport damage.

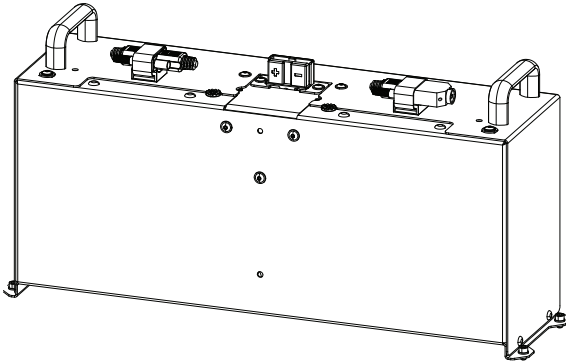

Check the exterior of the battery for damage that may have occurred during transport. Inspect for scratches, loose or displaced items, impacts, or other signs of damage. If any signs of damage are present, stop this procedure and contact the shipping company immediately to report the damage.

- 3** Save the shipping box and packaging material for future use.
This completes the procedure.

2-3 Battery Installation

Installation or removal of the battery must be performed by persons who have read and understood this manual.

Before you begin, turn the AMR OFF: place the Selection Switch and the Main Disconnect Switch in the OFF position.

WARNING

Do not damage the battery by subjecting it to impacts or shocks. Using a damaged battery can result in fire or other dangerous conditions.



Additional Information

Inspect the empty battery compartment and remove any foreign objects before attempting to install a battery.



Precautions for Correct Use

Always lift the battery using the two handles on top of the battery enclosure.

2-3-1 Battery Installation and Connection Procedure

Use the following procedure to install the battery and connect it to the AMR.

The following items are required for this procedure.

- The battery assembly (part number 28110-020)
- Triangle spanner key (included)
- Four bolts to attach the battery (included)
- 3 mm hex bit

- 1** Turn the AMR OFF. Refer to 3-2 *AMR Shut-down Procedure* on page 3-4 for more information.
- 2** Remove the Front Skin by loosening the two machine locks with the triangle spanner key.

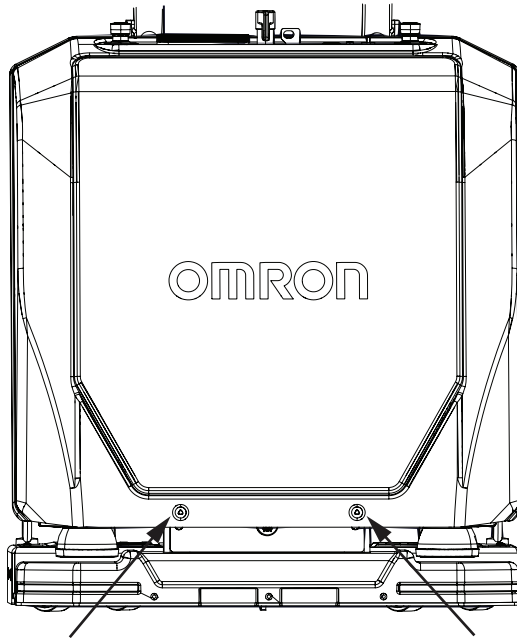

Refer to 3-5 *Removing and Replacing Skins* on page 3-8 for more information.

- 3** Carefully place the battery on the base plate of the AMR by aligning the holes on the battery over the four holes on the base plate.

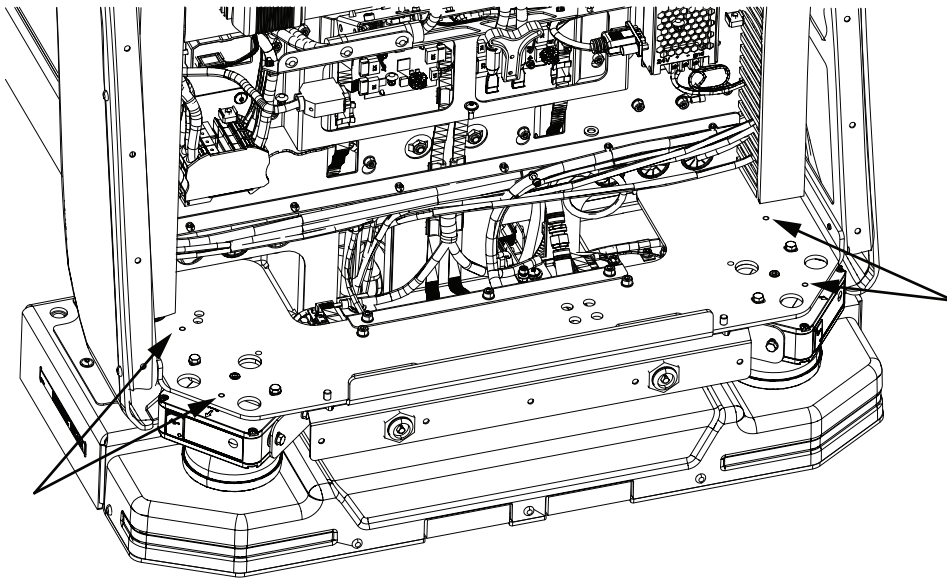

- 4** Insert the four bolts (two on each side) and tighten to a torque of 7 N-m to secure the battery to the base plate.

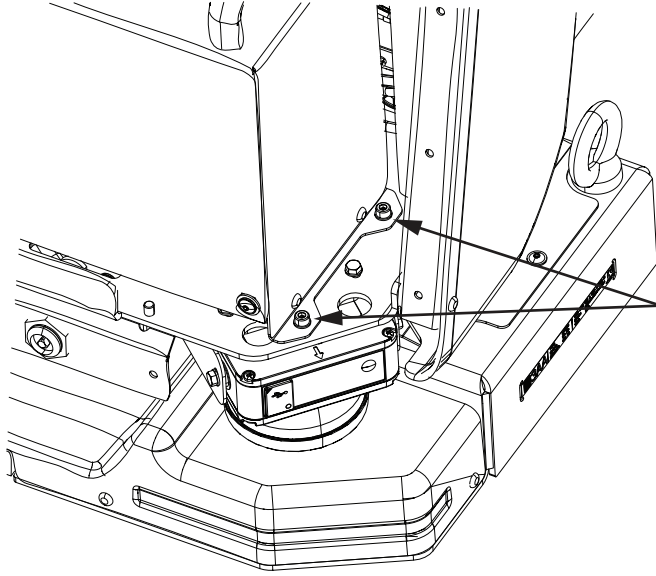

- 5** Connect the two CAN connectors of the battery with the DB9 connectors of the AMR and tighten the straps.

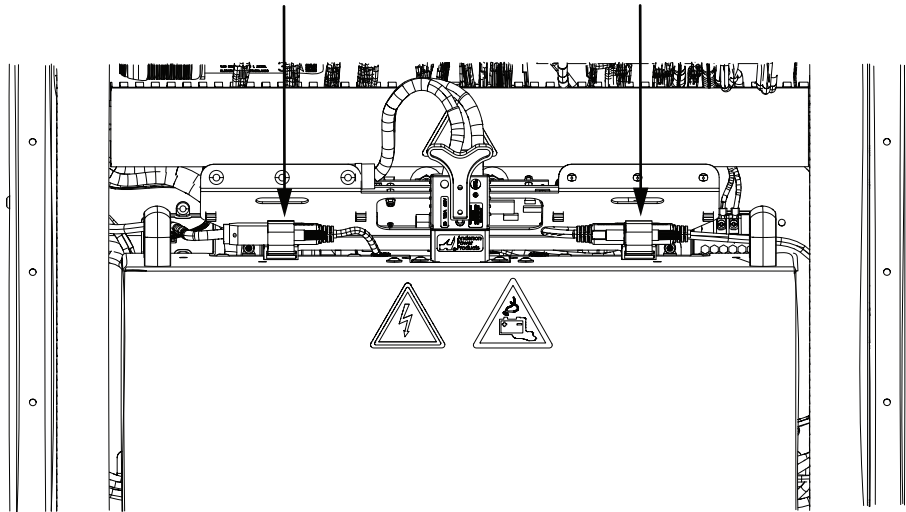

- 6** Insert the battery power connector of the AMR into the Anderson Powerpole socket in the battery.

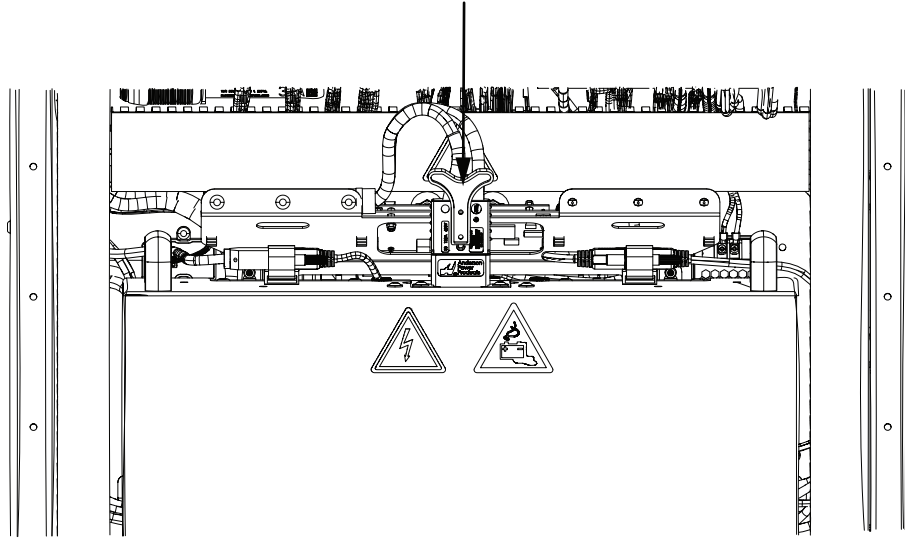

- 7** Replace the Front Skin and tighten the two machine locks to complete this procedure.

3

Supplementary Information

This section contains information to support the battery installation details.

3-1	AMR Start-up	3-2
3-1-1	AMR Start-up Procedure	3-2
3-2	AMR Shut-down Procedure	3-4
3-3	Charging AMR Battery	3-5
3-4	Charging Battery for the First Time	3-6
3-4-1	Charge Using Service Charger	3-6
3-4-2	Automatic Drive Mode Charging	3-7
3-5	Removing and Replacing Skins	3-8
3-5-1	Remove Front Skin.....	3-8
3-5-2	Replace Front Skin.....	3-9
3-6	Service Charger Specifications	3-10

3-1 AMR Start-up

This section provides details about AMR start-up procedure.

Ensure the following conditions are met before attempting to start-up the AMR.

- The battery is sufficiently charged. Refer to 3-3 *Charging AMR Battery* on page 3-5 for more information.
- Ensure the Front and Rear Skins are closed.
- Check the workspace of the AMR for improper objects and remove them.
- Ensure the Front Safety Scanners, the Rear Scanner and the 360-degree Scanner are clean and functional.
- Keep the Lifting Plate clean and free of conductive objects such as metals, carbon etc.



Precautions for Safe Use

Do not operate the AMR without all skins fastened correctly. Moving parts are exposed when the AMR is in motion.



Precautions for Correct Use

Implementing methods to circumvent the need for a person to enable the AMR's motor power at start-up is prohibited.

3-1-1 AMR Start-up Procedure

At start-up, the AMR powers all of its systems, including all factory and user configurations. It then automatically runs its on-board software and customer integrated processes to provide an application-ready AMR. If a map has been created and stored, and the AMR is localized, the AMR will be capable of operating autonomously. Refer to *Fleet Operations Workspace Core User's Manual (Cat. No. 1635)* for information on map creation and localization.

- 1 Turn the Main Disconnect Switch to the ON position.

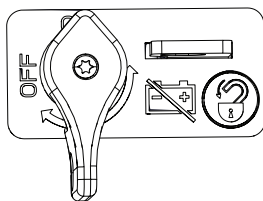

- 2 Turn the Selection Switch to the AUTO position to complete the procedure.

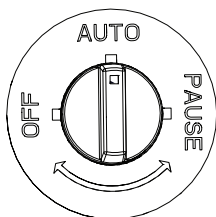

The Power LED lights up and the LED Signal Lamp, Front and Rear Light Strips turn ON.

It takes about one minute for all the systems to start-up and make their various interconnections. The AMR's Computing System and navigation lasers automatically start when the AMR turns ON.

3-2 AMR Shut-down Procedure

Follow the procedure below to shut down the AMR in a controlled manner. The system will save the AMR's last known location so it can automatically localize when it is powered ON later.

- 1 Turn the Selection Switch to the OFF position.

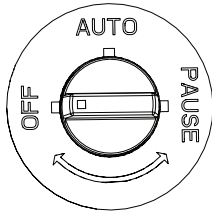

The Power LED, the Front and Rear Light Strips, and the LED Signal Lamp turn OFF.

- 2 Turn the Main Disconnect Switch to the OFF position.

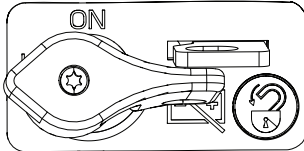

This completes the procedure.

3-3 Charging AMR Battery

The AMR features a coil (Mobile Coil) under the unit for wireless charging. When the AMR positions itself over the the Stationary Coil, current in the Stationary Coil generates a magnetic field between the two coils. This induces a current in the Mobile Coil and the battery charges wirelessly. This process is called induction charging.

The Charging Station is equipped with infrared communication for detection of the AMR at the charging position and communication between the Stationary Electronics and the Mobile Electronics in the AMR. When the Stationary and Mobile coils are aligned correctly, the system switches to charging mode and battery charging is initialized. When the Mobile Coil in the AMR moves away from the Stationary Coil, the connection is interrupted and the charging process stops automatically.

The AMR battery supplies adequate power for the motors, electronics, and accessories.

Typical runtime with no load is approximately 11 hours and typical fully loaded runtime is approximately 7 hours. The primary factors that affect runtime are AMR speed, acceleration, idle time at Goal locations, payload amount, and power consumed by accessories.

Check the battery's state-of-charge (SOC) percentage (%) using MobilePlanner.

DANGER

Do not charge a battery that has not been approved for the OL-series AMR. There is a risk of explosion when charging an incorrect battery. Failure to comply with the above mentioned instruction could result in damage to the Charging Station, battery, and AMR.



WARNING

The following actions are strictly prohibited and could result in injury or damage to the equipment.

- Persons with cardiac pacemakers in the AMR charging zone.
- Persons with metal implants in the AMR charging zone.
- Holding, placing, or allowing objects between the charging coils.



CAUTION

Never connect electric loads directly to the battery bypassing protective circuits.



Precautions for Safe Use

- The AMR must be powered ON in order to charge the battery while at the Charging Station.
- Do not touch the AMR charging coils. Coils get very hot during and after charging.

3-4 Charging Battery for the First Time

OMRON recommends that you charge the battery immediately after unpacking and installing the battery in the AMR for the first time. The battery is shipped with 30% state of charge (SOC) and discharging may have occurred during transport.



Precautions for Correct Use

IATA regulations (UN 3480, PI 965) require that air freight shipped lithium ion batteries not installed in the AMR must be transported at a state of charge not exceeding 30%. To avoid total discharge, fully charge the battery immediately upon receipt. The battery might arrive fully charged if it is not shipped by air freight.

There are two ways to charge the battery for the first time before a map of the workspace has been created for the AMR.

- Charge the battery using the Service Charger.
- Drive the AMR in Automatic Drive mode to the Charging Station for charging the battery.

Depending on the distance of the Charging Station set up in your facility, choose one of the two methods above to charge the battery.

3-4-1 Charge Using Service Charger

Follow the steps below to charge the battery using the Service Charger. The Service Charger can be used to charge the AMR battery for the first time or when the battery SOC is too low to drive the AMR to the Charging Station.

The Service Charger is rated to operate within a voltage range of 220 to 240 VAC at 50 to 60 Hz. Refer to 3-6 *Service Charger Specifications* on page 3-10 for more information.

If the Service Charger is supplied with power outside the rated voltage range, use a step-up transformer rated for a minimum of 750 W. OMRON recommends the Bronson++ WTI-4000 Voltage Converter.

CAUTION

The Service Charger cables pose a tripping hazard. Place cables in a manner that prevents tripping or isolate the area to prevent people from interacting with cables.



Precautions for Correct Use

Use only OMRON supplied Service Charger when the AMR state of charge is too low to allow docking.



Additional Information

After charging is complete, disconnect the Service Charger from the AMR and do not leave it connected to the AMR. The Service Charger will stop delivering current after the battery is fully charged.

- 1 Turn the Main Disconnect Switch to the ON position.
The AMR should remain powered ON during charging.

- 2 Set the Selection Switch to PAUSE to prevent any automatic or manual control of the AMR.
- 3 Connect the Service Charger cable to the Service Charger connector on the Control Strip of the AMR.

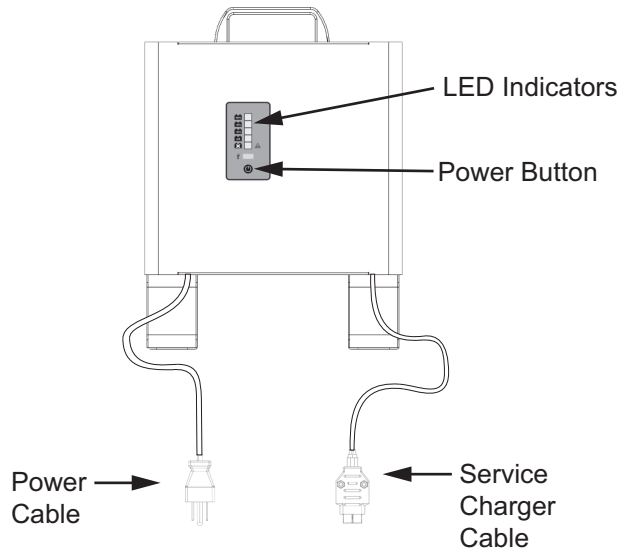

- 4 Connect the power cable of the Service Charger to a wall socket.
- 5 Press the Power button on the Service Charger.
The AMR battery begins charging.
The LED indicators on the Service Charger show the battery SOC.
The charging process takes approximately 2.5 hours to complete.

3-4-2 Automatic Drive Mode Charging

For initial charging before a workspace map has been created for the AMR, you can drive the AMR in Automatic Drive mode through MobilePlanner to the Charging Station for charging the battery. Refer to

- *Fleet Operations Workspace Core User's Manual (Cat. No. 1635)* for more information about installing and accessing MobilePlanner.
- *MobilePlanner Integrated Help* for more information about driving the AMR on Automatic Drive mode.

3-5 Removing and Replacing Skins

The Front and Rear Skins need to be removed or replaced during various maintenance and installation procedures.

The following sections gives details about removal and replacement of the Front Skin.



Additional Information

The Rear Skin is not a user-replaceable part. To remove or replace the Rear Skin, contact your local OMRON service representative.

3-5-1 Remove Front Skin

Follow the procedure below to remove the Front Skin from the AMR.

A triangle spanner key (included) is required for this procedure.

- 1 Turn the AMR OFF. Refer to 3-2 *AMR Shut-down Procedure* on page 3-4 for more information.
- 2 Loosen the two machine locks with the triangle spanner key (quarter turn to the left).

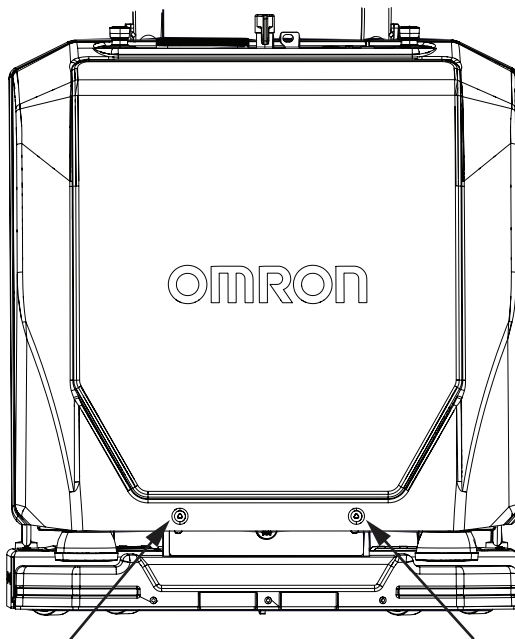

- 3 Lift up the Front Skin and remove it to complete this procedure.

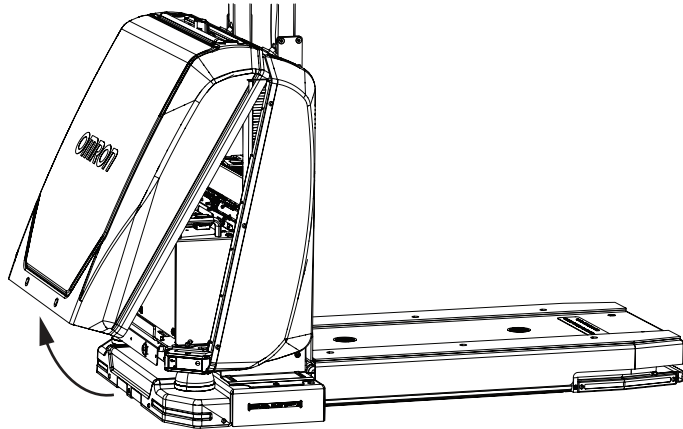

3-5-2 Replace Front Skin

Follow the procedure below to replace the Front Skin.

The following items are required for this procedure.

- A triangle spanner key (included)
- Replacement Front Skin (28110-726F)

- 1** Hook the Front Skin over the Control Strip to position it on the front of the AMR.

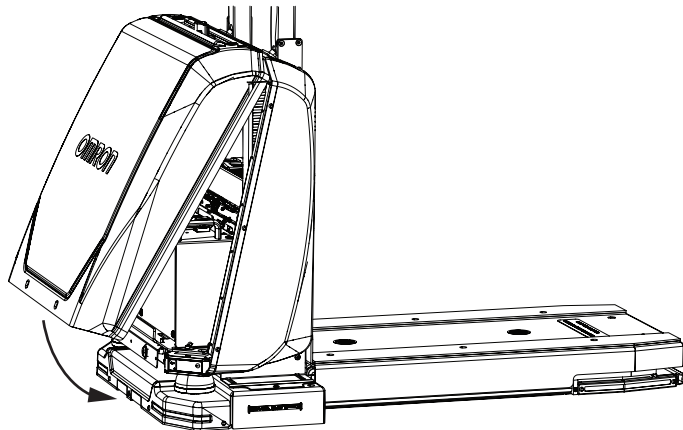

- 2** Tighten the two machine locks with the triangle spanner key (quarter turn to the right) to complete the procedure.

3-6 Service Charger Specifications

Specifications for the Service Charger are provided below.

Item	Specification
Input Voltage	220 to 240 VAC, 50 to 60 Hz
Maximum Input Current	2.2 A at 230 VAC
Output Voltage	24 VDC
Output Current	15 A (fused to 20 A)
Ambient Operating Temperature	0° to 35°C
Ingress Protection	IP21
Weight	3.5 kg

OMRON Corporation Industrial Automation Company

Kyoto, JAPAN

Contact : www.ia.omron.com

Regional Headquarters

OMRON EUROPE B.V.

Wegalaan 67-69, 2132 JD Hoofddorp
The Netherlands
Tel: (31) 2356-81-300 Fax: (31) 2356-81-388

OMRON ASIA PACIFIC PTE. LTD.

438B Alexandra Road, #08-01/02 Alexandra
Technopark, Singapore 119968
Tel: (65) 6835-3011 Fax: (65) 6835-3011

OMRON ELECTRONICS LLC

2895 Greenspoint Parkway, Suite 200
Hoffman Estates, IL 60169 U.S.A.
Tel: (1) 847-843-7900 Fax: (1) 847-843-7787

OMRON ROBOTICS AND SAFETY TECHNOLOGIES, INC.

4225 Hacienda Drive, Pleasanton, CA 94588 U.S.A.
Tel: (1) 925-245-3400 Fax: (1) 925-960-0590

OMRON (CHINA) CO., LTD.

Room 2211, Bank of China Tower, 200 Yin Cheng Zhong Road,
PuDong New Area, Shanghai, 200120, China
Tel: (86) 21-6023-0333 Fax: (86) 21-5037-2388

Authorized Distributor:

©OMRON Corporation 2023 All Rights Reserved.
In the interest of product improvement,
specifications are subject to change without notice.

Cat. No. M112-E-01 0325

25345-300 A