

## Quattro 650H/650HS/ 800H/800HS ePLC

### Quick Setup Guide



# Copyright Notice

The information contained herein is the property of Omron Adept Technologies, Inc., and shall not be reproduced in whole or in part without prior written approval of Omron Adept Technologies, Inc. The information herein is subject to change without notice and should not be construed as a commitment by Omron Adept Technologies, Inc. This manual is periodically reviewed and revised.

Omron Adept Technologies, Inc., assumes no responsibility for any errors or omissions in this document. Critical evaluation of this manual by the user is welcomed. Your comments assist us in preparation of future documentation. Please email your comments to: [tech-pubs@adept.com](mailto:tech-pubs@adept.com).

Copyright© 2013, 2016 by Omron Adept Technologies, Inc. All rights reserved.

Any trademarks from other companies used in this publication are the property of those respective companies.

Printed in the United States of America

# Chapter 1: Quattro ePLC Robot Quick Setup

## 1.1 Introduction

### Process Overview

This Quick Setup Guide presents the steps that are specific to a Quattro ePLC installation. The major steps are:

- **Preparation**, including workcell layout and safety
- **Hardware Installation**, including mounting the robot and system cable connections
- **System Start-Up**, including system configuration and tuning on the robot

It is assumed that the following have been completed. Refer to the Quattro Robot User's Guide for information on these steps:

- Design and construction of a robot frame
- Installation of the robot cable box and cable tray on robot (Quattro HS)
- Attachment of the outer arms and platform on the robot

**NOTE:** This guide does not apply to robot systems that include a SmartController motion controller. Refer to the Quattro Robot User's Guide for those systems.

During the installation and start-up process, refer to the Quattro Robot User's Guide, for more information on your robot system. Also refer to your PLC user's guide.

### Resources on the Support Disk

- This guide (along with three other ePLC robot quick setup guides)
- The *Quattro s650/800 User's Guide*

### Resources on Omron Web Sites

On the Omron Industrial Automation web site:

[ia.omron.com](http://ia.omron.com)

- The *ePLC Connect 3 Software User's Guide*
- EtherNet/IP Connection Guide (P649-E1-01)  
This covers ePLC for the Omron NJ controller with Omron Adept Robots.
- EtherNet/IP Connection Guide (P650-E1-01)  
This covers ePLCIO for the Omron NJ controller with Omron Adept robots

On the Omron Adept web site:

[adept.com](http://adept.com)

- Legacy systems communication structure pdfs
- Legacy systems code examples

## 1.2 Safety



**WARNING:** It is strictly prohibited to install or operate a robot without adequate safeguards according to applicable local and national standards. See Figure 1-1. for a simple workcell layout.

You must read the *Robot Safety Guide* and the Robot Installation and Operation chapters in the robot user's guide for information on safe operation of your robot system.

Refer to Installing User-Supplied Safety Equipment in the System Installation chapter of the robot user's guide, which provides details on connecting a user-designed E-Stop system to the XUSR connector on the robot.

## 1.3 Workcell Layout

The following figure shows a simple workcell layout with a user-supplied safety barrier and E-Stops provided by the Front Panel and optional T20 pendant.

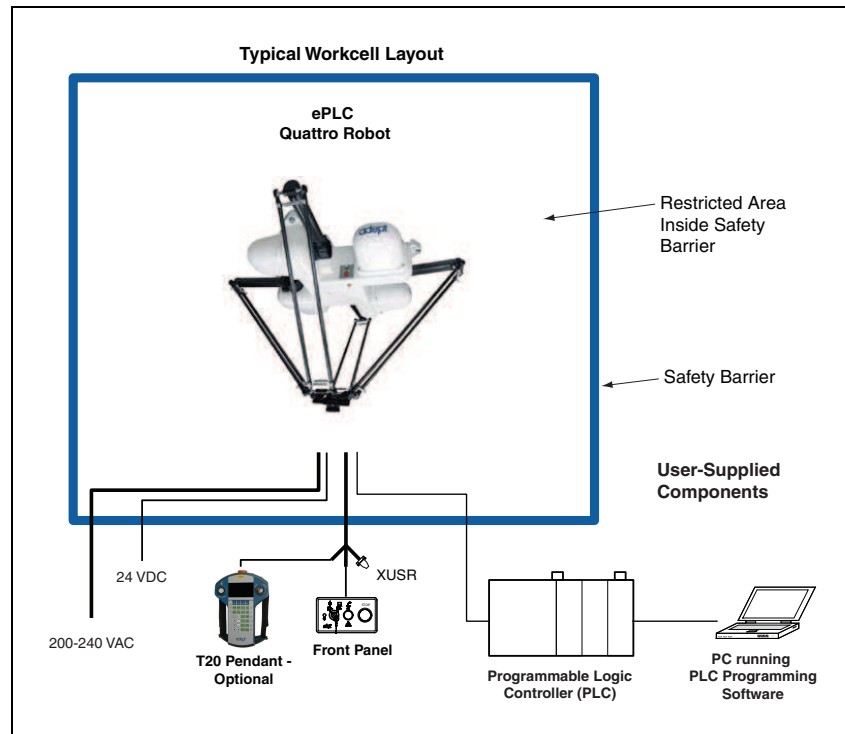

Figure 1-1. Typical Workcell Layout

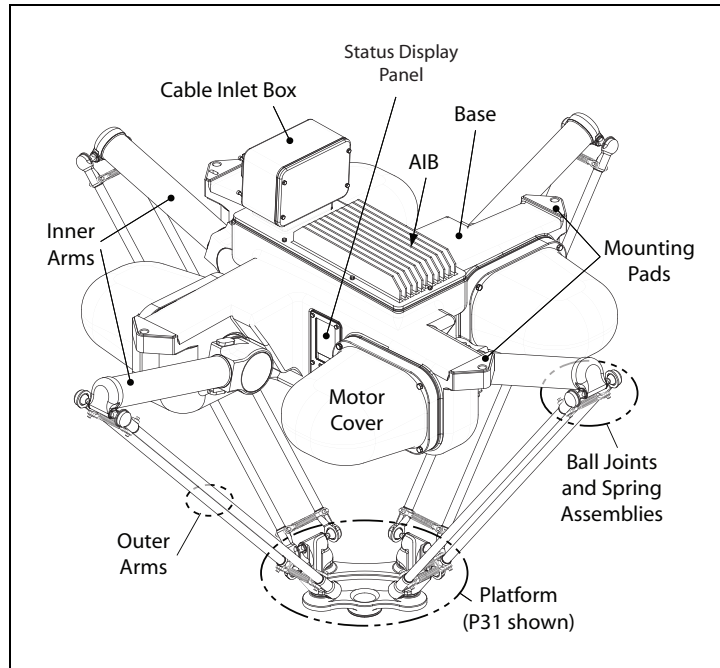

Figure 1-2. Quattro Robot Components, 650HS Robot Shown

## 1.4 Installing the Robot

### Frame

The Quattro robot is mounted in a user-supplied frame, so that it hangs over the workspace. A sample frame design is given, with dimensions, in the user's guide. See the following figure.

Ensure that the robot is oriented such that the Status Display panel faces away from the conveyor, if your system has a conveyor. This will give you the best view of the Status Display panel, and provide the best cross-belt movement of the robot's platform.

### Mounting the Robot

Depending on your frame design, the robot can be mounted from either above or below the frame, and to either the top or bottom of the frame pads.

**NOTE:** All mounting hardware is user-supplied. Refer to Install Mounting Hardware on page 7.

	Top of Pads	Bottom of Pads
<b>From Above Frame</b>	Eye bolts or Slings	Slings
<b>From Beneath Frame</b>	Eye bolts or Slings	Slings or Fork lift with pad

### Using Eye Bolts:

1. Remove all lag bolts from the robot base mounting pads.
2. Screw the M16 eyebolts into opposing robot mounting pads, so that the robot will be balanced when lifted.
3. Lock each eyebolt with a jam nut.
4. Connect slings to the M16 eyebolts and take up any slack in the slings.



**CAUTION:** Do not to lift the robot from any points other than the eyebolts. Failure to comply could result in the robot falling and causing either personnel injury or equipment damage.

5. Lift the robot and position it directly over the mounting frame pads.  
If lifting from inside the frame, you will have to twist the robot so that its mounting pads clear the frame mounting pads, and you can raise it above the frame.
6. Slowly lower the robot while aligning the M16 holes in the robot mounting pads with the holes in the frame mounting pads.
7. When the mounting pad surfaces are touching, start a bolt in each of the two unused mounting holes.
8. Remove the slings and M16 eyebolts.
9. Refer to the table in Install Mounting Hardware on page 7 for mounting bolt torques.

### Using Slings:

**NOTE:** Nylon slings can be wrapped across the center of the robot base, away from the inner arms and status display. See the following figure.

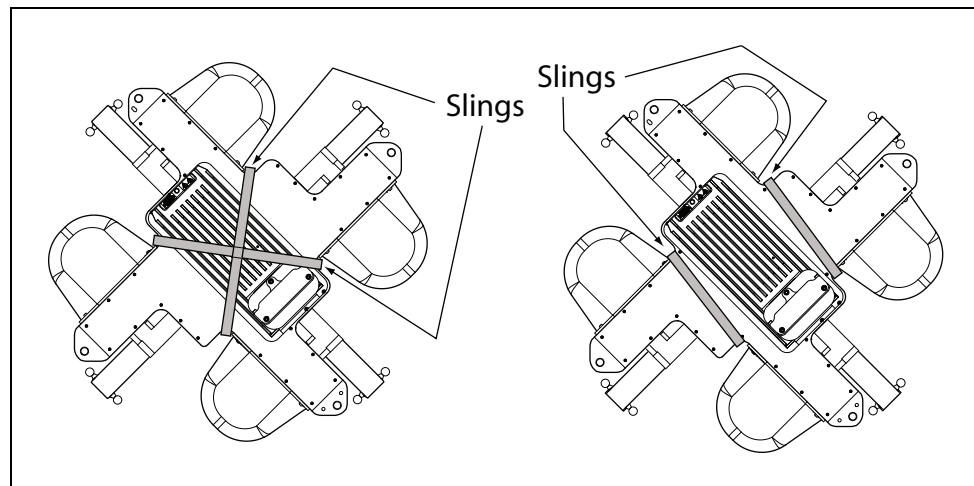

Figure 1-3. Safe Locations for Lifting a Quattro with Nylon Slings

1. Remove all lag bolts from the robot base mounting pads.
2. Wrap slings around the robot base. See the preceding figure for two methods.
3. Lift the robot and position it directly over or under the frame mounting pads.  
For above lift/bottom mount or below lift/top mount, you will have to rotate the robot so that its mounting pads clear the frame mounting pads.
4. Refer to the following table for mounting bolt torques.

Using a Forklift:

1. Remove all lag bolts from the robot base mounting pads.
2. Lift the robot and position it directly over or under the frame mounting pads.  
Use a padded board as a support under the robot base.  
If you want to mount to the top of the frame's mounting pads, you will have to twist the robot so that its mounting pads clear the frame mounting pads, and you can raise them above the frame.
3. Refer to the table that follows for mounting bolt torques.

### Install Mounting Hardware

**NOTE:** When mounting the robot, note the following:

1. Place split lock, then flat washers on the bolts.  
Bolts are M16 x 2.0 if threaded into the robot base mounting tabs.  
Bolts are M12 or ½ in. if going through the robot base mounting tabs into nuts.  
**NOTE:** When M16 x 2.0 bolts are used, the bolt must engage at least 24 mm into the threads of the base mounting pad.
2. Insert the bolts through the holes in the frame mounting pads and into the threaded holes in the robot base mounting pads.  
If using through-bolts, insert the bolts through the holes in both the mounting pads and through the threaded holes in the robot base mounting pads into nuts.
3. Tighten the mounting hardware to the specifications listed in the following table.

*Table 1-1. Mounting Bolt Torque Specifications*

Standard	Size	Minimum Specification	Torque
Threaded into base (aluminum):			
Metric	M16 x 2.0	ISO Property Class 5.8	98 N·m (74 ft-lb)
Using base mounting pad hole as through-hole:			
Metric	M12	ISO Property Class 9.8	100 N·m (75 ft-lb)
SAE	½ in.		100 N·m (75 ft-lb)

**NOTE:** Check the tightness of the mounting bolts one week after initial installation, and then recheck every 6 months. For periodic maintenance, refer to the Quattro User's Guide.

## 1.5 System Cable Connections

Open the Accessory box and locate the eAIB XSYSTEM cable. Connect the cables and peripherals as shown in the following figure. Parts and steps are covered in the following two tables. Refer to the System Installation chapter in your *Quattro User's Guide* for power specifications and wiring instructions.

Part	Cable and Parts List	Part #	Part of:	Notes
A	eAIB XSYSTEM Cable Assembly	13323-000		standard, eAIB
B	User E-Stop, Safety Gate	n/a	n/a	user-supplied
C	XUSR Jumper Plug	04736-000	13323-000	standard, eAIB
D	Front Panel	90356-10358		standard
E	Front Panel Cable	10356-10500	90356-10358	standard
F	Front Panel Jumper Plug	10053-000	13323-000	standard, eAIB
G	XMCP Jumper Plug	04737-000	13323-000	standard, eAIB
H	T20 Bypass Plug	10048-000	10055-000	standard, T20
J	T20 Adapter Cable	10051-003	10055-000	standard, T20
K	T20 Pendant (option)	10055-000		option
L	AC Power Cable (option)	04118-000	90565-010	user-supplied
M	24 VDC Power Cable (option)	04120-000	90565-010	user-supplied
N	24 VDC, 6 A Power Supply (option)	04536-000	90565-010	user-supplied
P	Ethernet Cable - PC -> PLC (Only while programming PLC)	n/a	n/a	user-supplied
Q	Ethernet Cable - PLC -> switch	n/a	n/a	user-supplied
R	Ethernet Cable - switch -> SmartVision MX	n/a	n/a	user-supplied
S	Ethernet switch, cable	n/a	n/a	user-supplied
T	Camera and cable	n/a	n/a	option

### Power Requirements

The power requirements for the SmartVision EX and the Quattro robots are covered in their respective user guides. For 24 VDC, both can be powered by the same power supply.



**NOTE:** The resistance of all ground conductors must be  $\leq 10 \Omega$ .

Step	Connection	Part
1	Connect eAIB XSYSTEM cable to XSYSTEM on eAIB	A
2	Connect a user E-Stop or Muted Safety Gate to the eAIB XSYSTEM cable XUSR connector or	B
2a	verify XUSR jumper plug is installed in eAIB XSYSTEM cable XUSR connector.	C
3	Connect Front Panel cable to Front Panel and eAIB XSYSTEM cable XFP connector or	D, E
3a	if no Front Panel, install FP jumper on eAIB XSYSTEM cable XFP connector. See NOTE after table.	F
4	Connect T20 adapter cable to eAIB XSYSTEM cable XMCP connector or	J, K
4a	if no T20, install XMCP jumper or T20 Adapter Cable with T20 bypass plug.	G or H
5	Connect user-supplied ground to robot. See robot user's guide for location.	n/a
5a	Connect user-supplied ground to SmartVision MX, if used. See SmartVision MX user's guide for location.	n/a
6	Connect 200-240 VAC to AC Input on eAIB Interface Panel; secure with clamp.	L
7	Connect 24 VDC to DC Input on Interface Panel.	N, M
7a	Connect 24 VDC to SmartVision MX, if used.	N, M
8	Connect Ethernet cable from PC to PLC.	P
9	Connect Ethernet cable from PLC to switch.	S
9a	Connect Ethernet cable from switch to eAIB.	Q, S
9b	Connect Ethernet cable from SmartVision MX, if used, to switch.	R, S
10	Connect optional camera and cable to SmartVision MX, if used.	T

**NOTE:** A front panel ships with each Quattro ePLC system, but you can choose not to use it if you replace its functionality with equivalent circuits. That is beyond the scope of this guide.

## 1.6 Configuration

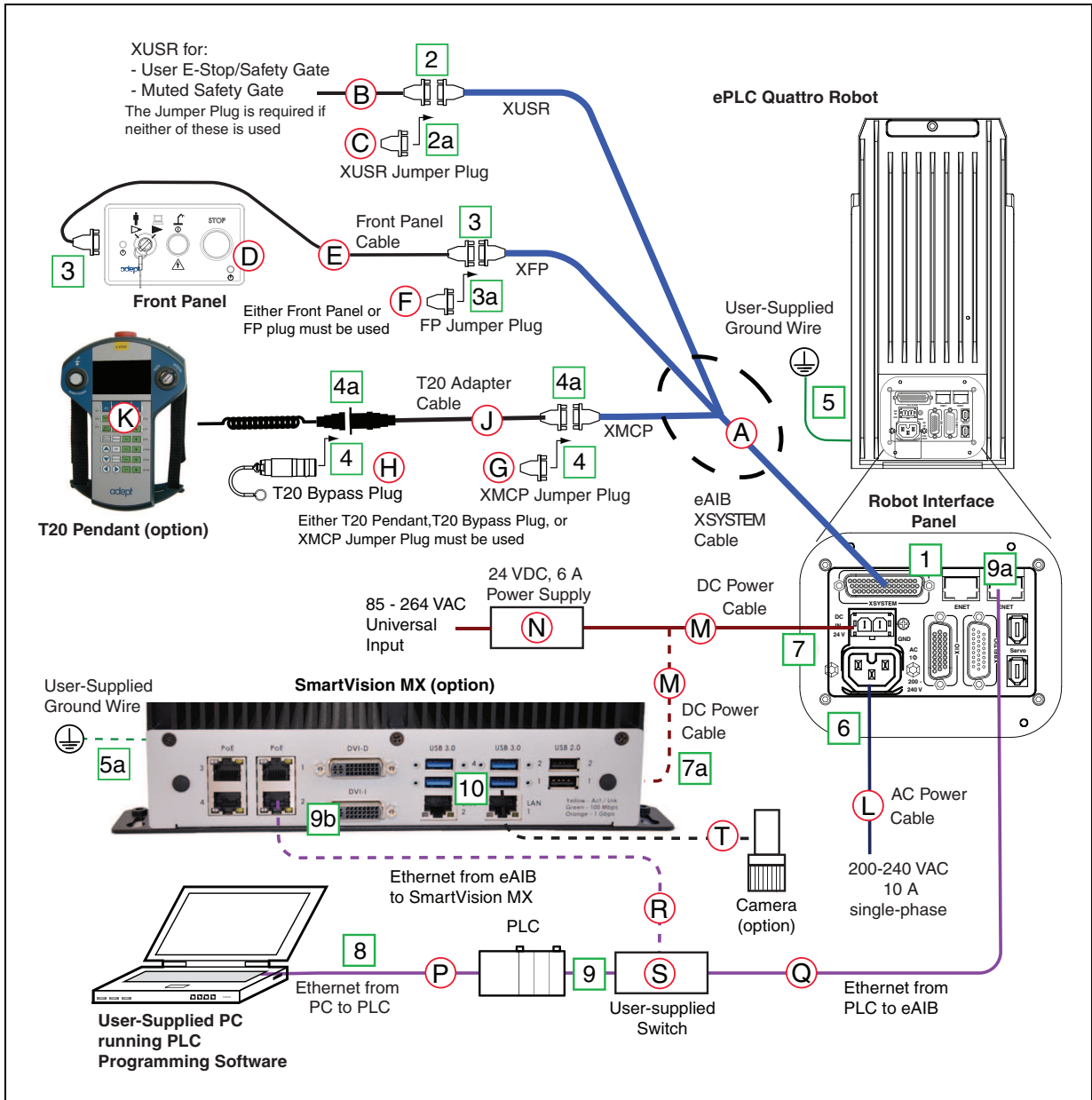

Figure 1-4. Configuration with Vision

## 1.6 Configuration

The user-supplied PLC and the Quattro robot are connected either through a shared network or via a user-supplied Ethernet cable.

When the Quattro ePLC robot is powered on and waiting for a PLC connection, the robot status panel will display its IP address, two digits at a time.

The format will be:

IP xxx-xxx-xxx-xxx OK

**NOTE:** If you can use the robot's default IP address, then you can skip the ACE software installation completely.

## Installing ACE Software

ACE is used to change the IP address of the robot and for troubleshooting. You install the ACE software onto your PC from the software disk.

**NOTE:** You will have to restart the PC after installing ACE software.

## Setting the Robot IP Address

Configure the IP address of the Quattro ePLC robot using ACE software.

1. Connect the PC and the robot, either through a shared network or with an Ethernet cable between them.
2. Start the ACE software.
3. Click the Detect and Configure button, circled in the following figure.

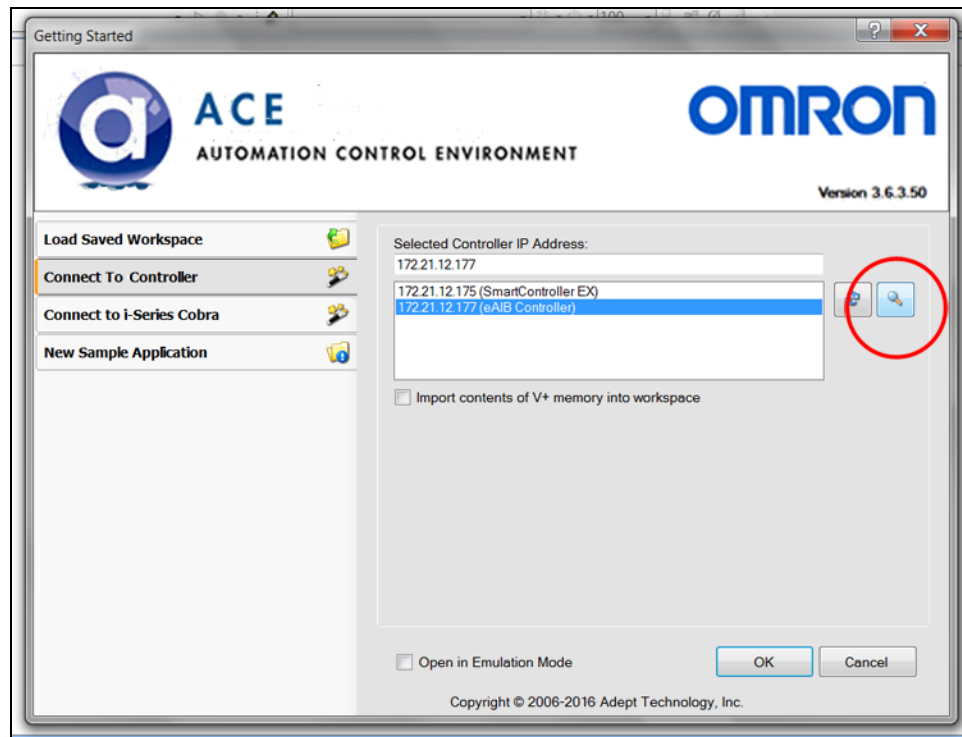

Figure 1-5. Detect and Configure Button

The IP address detection and configuration window will open. The ACE software will show the IP address of any controllers it detects. See the following figure.

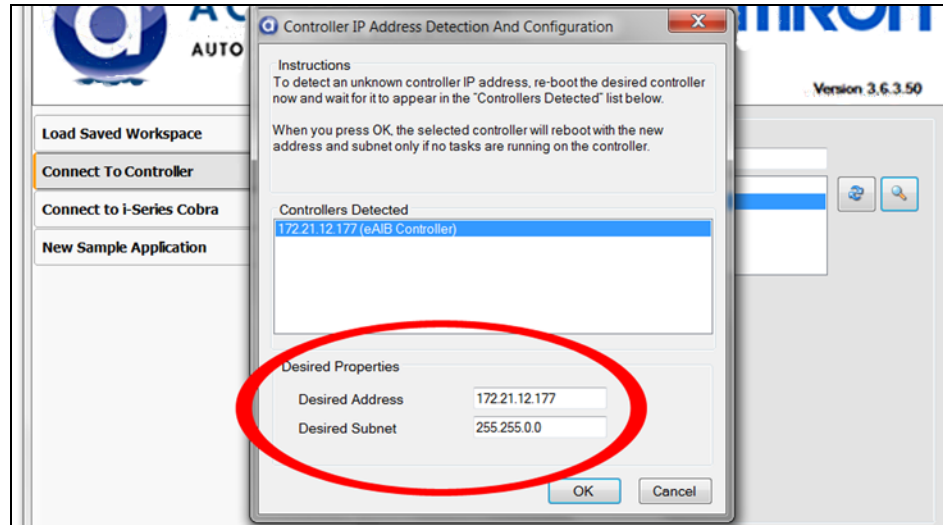

Figure 1-6. IP Addresses Detected

4. You can change the IP address and subnet mask in the Desired Address and Desired Subnet fields, if needed.
5. Click OK. The ACE software will ask you to wait for the controller to reboot.

### Configuring the Omron PLC

Refer to the EtherNet/IP Connection Guide (P649-E1-01) for configuring the Omron PLC to work with Omron Adept robots. Refer to Resources on Omron Web Sites on page 3.

Using your PLC software, set the IP address for the PLC to connect to on the robot.

### Enabling High Power

The details of enabling high power to the robot are covered in the EtherNet/IP Connection Guide (P649-E1-01).

Once high power is enabled, the Robot Status Panel displays ON, and the amber Robot Status LED is on.

## 1.7 Finding Additional Information

### Installing Optional Equipment

For details on installing optional equipment, see the following topics in the Optional Equipment Installation chapter of the *Quattro User's Guide*:

- Installing end-effectors
- Connecting user air and electrical lines to user connection panel
- Mounting external equipment on the robot
- Mounting the robot solenoid option kit

**NOTE:** For dimensions and specifications, see Technical Specifications in the *Quattro User's Guide*.

## System Operation

For details on system operation, see the following topics in the System Operation chapter of the *Quattro User's Guide*:

- Robot Status LED Indicator
- Status panel fault codes
- Brake Release button (located above or in diagnostic panel).
- Connecting digital I/O on the XIO connector at the robot interface panel
- Connecting a user-designed E-Stop System

For information on the ePLC Connect software interface, refer to the *ePLC Connect 3 Software User's Guide*.





**OMRON Corporation Industrial Automation Company**

Kyoto, JAPAN

Contact: [industrial.omron.eu](http://industrial.omron.eu)

**Regional Headquarters**

**OMRON EUROPE B.V.**

Wegalaan 67-69, 2132 JD Hoofddorp  
The Netherlands  
Tel: (31)2356-81-300/Fax: (31)2356-81-388

**OMRON ELECTRONICS LLC**

2895 Greenspoint Parkway, Suite 200 Hoffman Estates,  
IL 60169 U.S.A.  
Tel: (1) 847-843-7900/Fax: (1) 847-843-7787

**OMRON ASIA PACIFIC PTE. LTD.**

No. 438A Alexandra Road # 05-05/08 (Lobby 2),  
Alexandra Technopark,  
Singapore 119967  
Tel: (65) 6835-3011/Fax: (65) 6835-2711

**OMRON ADEPT TECHNOLOGIES, INC.**

4550 Norris Canyon Road, Suite 150, San Ramon, CA 94583 U.S.A.  
Tel: (1) 925-245-3400/Fax: (1) 925-960-0590

**OMRON (CHINA) CO., LTD.**

Room 2211, Bank of China Tower, 200 Yin Cheng Zhong Road,  
PuDong New Area, Shanghai, 200120, China  
Tel: (86) 21-5037-2222/Fax: (86) 21-5037-2200

Authorized Distributor:

© OMRON Corporation 2016 All Rights Reserved.  
In the interest of product improvement,  
specifications are subject to change without notice.

Printed in USA

Cat. No. I598-E-01

0416