

Delta 2+1 Robot
IP65 protection class

CR_UGD2800 Series

USER'S MANUAL

OMRON

Safety Instructions

1. Attention	S-1
2. Explanation of warnings and notes	S-1
3. Safety information	S-2
3.1 General	S-2
3.2 Qualified personnel	S-2
3.3 Liability	S-2
3.4 Installation and operating conditions	S-2
3.5 Residual risks	S-2
3.5.1 Release device	S-3
3.5.2 Transport	S-3
3.5.3 Assembly and start-up	S-3
3.5.4 Maintenance and repair	S-3
3.5.5 System integrator	S-4

Chapter 1 Introduction

1. Introduction	1-1
1.1 Description of the robot	1-1
1.2 Type code explanation	1-1
2. Identification	1-1
3. Part names	1-2

Chapter 2 Model overview

1. Overview	2-1
-------------	-----

Chapter 3 Installation

1. Unpacking	3-1
1.1 Unpacking the shipping box	3-1
1.2 Check the damage	3-1
1.3 Lifting and transportation	3-2
2. Mounting the robot	3-3
3. Calibration (Robots with serial number 2264 or higher)	3-4

4. Calibration (Robots with serial number 2263 or lower)	3-6
--	-----

5. Gripper interface	3-9
----------------------	-----

Chapter 4 Maintenance

1. Periodic maintenance (Robots with serial number 2264 or higher)	4-1
--	-----

1.1 Removing the secondary arms	4-1
---------------------------------	-----

1.2 Mounting the secondary arms	4-2
---------------------------------	-----

1.3 Rotational axis	4-2
---------------------	-----

2. Periodic maintenance (Robots with serial number 2263 or lower)	4-4
---	-----

2.1 Removing the secondary arms	4-4
---------------------------------	-----

2.2 Mounting the secondary arms	4-5
---------------------------------	-----

2.3 Rotational axis	4-6
---------------------	-----

2.4 Springs	4-7
-------------	-----

2.5 Ball bearing cups	4-7
-----------------------	-----

3. Cleaning the robot	4-8
-----------------------	-----

4. Spare parts	4-8
----------------	-----

Chapter 5 Robot settings

1. Kinematics	5-1
---------------	-----

2. Workspace	5-2
--------------	-----

3. Software limits	5-3
--------------------	-----

Chapter 6 Specifications

1. Basic specifications	6-1
-------------------------	-----

1.1 Cycle time	6-1
----------------	-----

2. External view and dimensions	6-2
---------------------------------	-----

3. Design specifications	6-3
--------------------------	-----

3.1 Occupation area of robot	6-3
------------------------------	-----

3.2 Software design	6-4
---------------------	-----

3.2.1 Dimensions and limits	6-4
-----------------------------	-----

Safety Instructions

Contents

1. Attention	S-1
2. Explanation of warnings and notes	S-1
3. Safety information	S-2
3.1 General	S-2
3.2 Qualified personnel	S-2
3.3 Liability	S-2
3.4 Installation and operating conditions	S-2
3.5 Residual risks	S-2
3.5.1 Release device	S-3
3.5.2 Transport	S-3
3.5.3 Assembly and start-up	S-3
3.5.4 Maintenance and repair	S-3
3.5.5 System integrator	S-4

1. Attention

Information in this document can change without prior notice.

OMRON EUROPE B.V. cannot be held responsible for any damage to the environment, to the machine or to the functioning of the machine occurred by errors or missing data in the illustrations, drawing or specifications.

No part of this manual and added documentation may be copied, reproduced or translated into another language without prior written approval.

Read and understand the material contained in this user's manual before you work on the CR_UGD2800 robot for the first time. This user's manual is supposed to help you use the capabilities of the CR_UGD2800 robot safely and properly.

2. Explanation of warnings and notes

This manual uses the following safety alert symbols and signal words to provide safety instructions that must be observed and to describe handling precautions, prohibited actions, and compulsory actions. Make sure you understand the meaning of each symbol and signal word and then read this manual.

**DANGER**

THIS INDICATES AN IMMEDIATELY HAZARDOUS SITUATION WHICH, IF NOT AVOIDED, WILL RESULT IN DEATH OR SERIOUS INJURY.

**WARNING**

THIS INDICATES A POTENTIALLY HAZARDOUS SITUATION WHICH, IF NOT AVOIDED, COULD RESULT IN DEATH OR SERIOUS INJURY.

**NOTE**

Explains the key point in the operation in a simple and clear manner.

3. Safety information

3.1 General

This '3. Safety information' subchapter contains information regarding working with the CR_UGD2800 robot. Qualified personnel working with the CR_UGD2800 robot must have read and understood the CR_UGD2800 robot documentation, including the safety information chapter.

3.2 Qualified personnel

These are people who, due their specialist training, knowledge and experience, and their familiarization with the relevant standards, are able to assess the work to be carried out and detect any potential hazards.

3.3 Liability

The CR_UGD2800 robot is build using state-of-the-art technology and in accordance with the recognized safety rules. Nevertheless, misuse of the CR_UGD2800 robot may constitute a risk to life and limb or cause damage to the CR_UGD2800 robot and to other material property.

3.4 Installation and operating conditions

You may only use the components in accordance with the installation and operating conditions described in the documentation. The operating conditions at the installation location must be checked and maintained in accordance with the required technical data. Within the meaning of the Machinery Directive the CR_UGD2800 robot is an incomplete machine. Commissioning is prohibited until the usable machine or system in which the CR_UGD2800 robot is installed meets all requirements of the Machine directive 2006/42/EC.

For the CR_UGD2800 robot you have to observe the following standards, directives and regulations:

- EN ISO 10218-1:2011 Robots and robotic devices - Safety requirements for industrial robots - Part 1: Robots.
- EN ISO 10218-2:2011 Robots and robotic devices - Safety requirements for industrial robots - Part 2: Robot systems and integration.

3.5 Residual risks

Safety and health risks arising from the robot mechanics have been reduced by means of safety technology and design engineering. However a residual risk remains, since the robot mechanics will be move by an automated control system.

The following are typical warnings concerning residual risks which cannot be assigned to a specific action. The expression of safety labels is identical to the safety information.

3.5.1 Release device

The robot mechanics are not supplied with an release switch to control the brakes of the motors.

**WARNING**

- MOUNT A RELEASE SWITCH ON THE MACHINE SO THE ARMS (MOTOR) OF THE ROBOT COULD BE MANUALLY MOVED.
 - MOVING AN AXIS WITH AN IMPROPERLY WORKING RELEASE SWITCH CAN DAMAGE THE MOTOR BRAKE. THIS CAN RESULT IN PERSONAL INJURY AND MATERIAL DAMAGE.
 - BEFORE RELEASING THE BRAKE, YOU HAVE TO BE SURE THAT NO ONE IS IN THE HAZARD AREA OF THE ROBOT.
-

3.5.2 Transport

The prescribed transport position of the robot must be observed. Transportation must be carried out in accordance with the transportation instructions or assembly instructions of the robot.

**WARNING**

- ONLY USE AUTHORIZED HANDLING EQUIPMENT WITH A SUFFICIENT LOAD-BEARING CAPACITY TO TRANSPORT THE ROBOT.
 - WEAR SUITABLE PROTECTIVE CLOTHING IF NECESSARY.
-

3.5.3 Assembly and start-up

Before starting up systems and devices for the first time, a check must be carried out to ensure that the system and devices are completed and operational, that they can be operated safely and that any damage is detected.

The valid national or regional work safety regulations must be observed for this check. The correct functioning of all safety circuits must also be tested.

The following tests must be carried out before start-up and recommissioning. It must be ensured that:

- The robot is correctly installed and fastened in accordance with the specifications in the assembly instructions.
- There are no foreign bodies or loose parts on the robot.
- All required safety equipment is correctly installed and operational.

**WARNING**

- A WRONG INSTALLED ROBOT MAY DAMAGE HIS ARMS.
 - WEAR SUITABLE PROTECTIVE CLOTHING IF NECESSARY.
-

3.5.4 Maintenance and repair

After maintenance and repair work, checks must be carried out to ensure the required safety level. The valid national or regional work safety regulations must be observed for this check. The correct functioning of all safety circuits must also be tested.

The purpose of maintenance and repair work is to ensure that the system is kept original or, in the event of a fault, to return the system to an operational state. Repair work includes troubleshooting in addition to the actual repair itself.

The following safety measures must be carried out when working on the robot:

- Switch of the machine (system) where the robot is built-in (e.g. with a padlock) to prevent it from being switched on again
- Label the machine (system) with a sign indication that work is in progress. This sign must remain in place, even during temporary interruptions to the work.
- The emergency stop from the machine (system) must remain active. If safety functions or safeguards are deactivated during maintenance or repair work, they must be reactivated immediately after the work is completed.

3.5.5 System integrator

The robot is safely integrated into a complete system by the system integrator. The system integrator is responsible for the following tasks:

- Installing the robot
- Performing risk assessment
- Implementing the required safety functions and safeguards
- Issuing the declaration of conformity
- Attaching the CE mark
- Creating the operating instructions for the complete system

Chapter 1 Introduction

Contents

1. Introduction	1-1
1.1 Description of the robot	1-1
1.2 Type code explanation	1-1
2. Identification	1-1
3. Part names	1-2

1. Introduction

Congratulations with the purchase of your high speed Delta robot.

This manual should be read before the commissioning of the robot. By mechanical engineers in the design phase during the integration of the robot in the machine and by software engineers to check the performance envelope of the robot.

This manual describes the main versions of the CR_UGD2800 robot, and all options. Where applicable check the appropriate data for your robot type, the type can be found on the identification tag of the robot.



1.1 Description of the robot

The CR_UGD2800 Delta robot is a high speed pick and place robot which uses carbon fiber, stainless steel and aluminum materials and the latest servo drive technology to be put in use in the most demanding pick and place applications. The robot is designed as a 2-axis (optional 3rd rotational axis) Delta kinematic system.

Characteristics of the robot:

- Requires very low maintenance
- 2 + 1 (rotational axis optional) degrees of freedom
- Compact design for mounting in a machine
- Low noise level < 68 dB (A)

1.2 Type code explanation

CR_UGD2800_R: 2 + 1 axes (with rotational axis), 800 mm working range, max. payload: 3 kg
CR_UGD2800_NR: 2 axes (without rotational axis), 800 mm working range, max. payload: 3 kg

2. Identification

On the robot base plate an identification tag is mounted, important data on this plate:

- Robot type
- Total weight of the robot
- Month and year of production
- Serial number, important for ordering spare parts

3. Part names

1

Introduction

CR_UGD2800 series (Robots with serial number 2264 or higher)

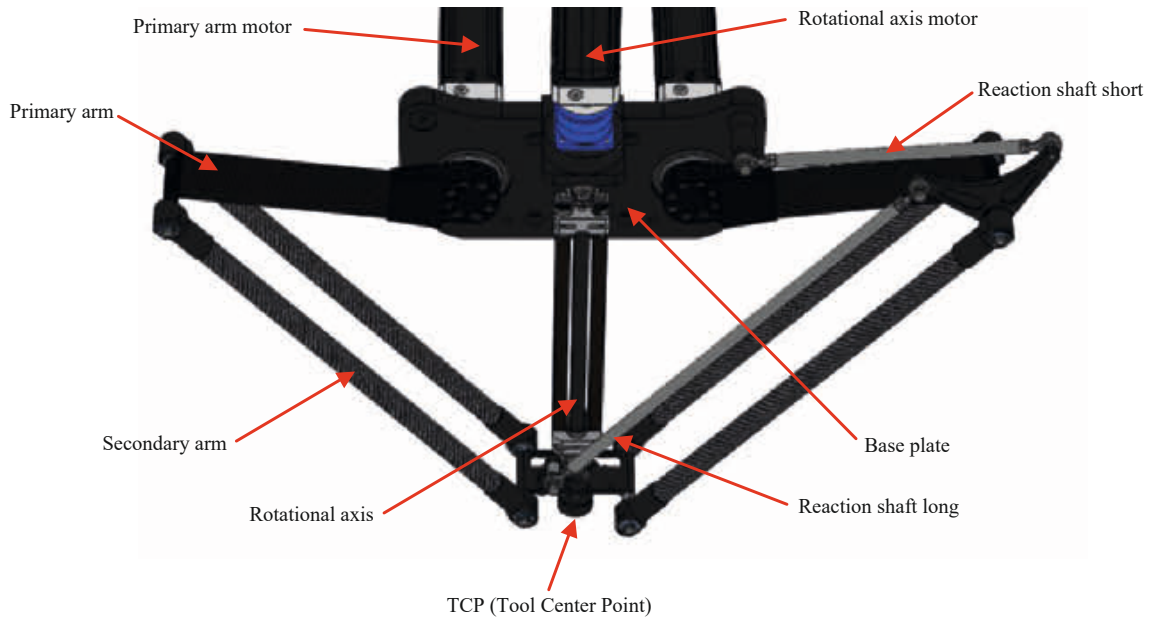

CR_UGD2800 series (Robots with serial number 2263 or lower)

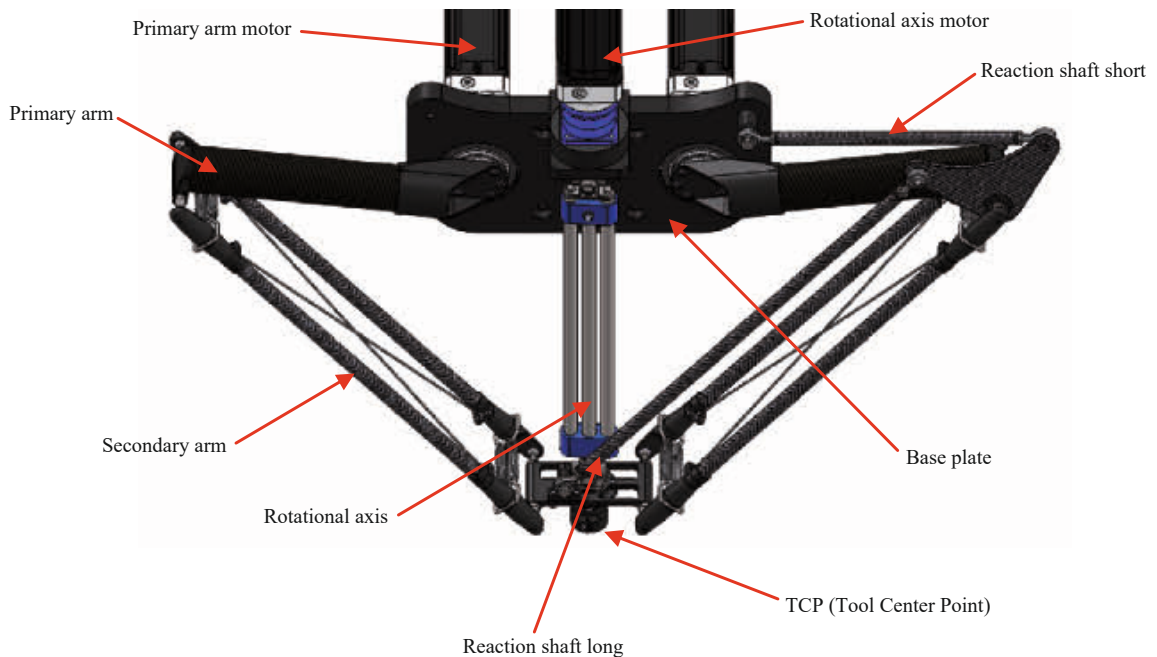

NOTE

Kinematics, workspace and dimensions are the same independently on the serial number of the robot.



NOTE

Improvements for Robots with serial number 2264 or higher:

- Ball bearing cups in the lower arms have been replaced by standard ball bearing
- Reaction shaft changed from carbon to stainless steel
- Sockets used in the upper arms are more stiffer
- No wires used in the secondary arms

Chapter 2 **Model overview**

Contents

1. Overview

2-1

1. Overview

The CR_UGD2800 has a working range of 800 mm. The specifications are given in the below figure, if specifications differ for models, it is indicated in the specification list.

CR_UGD2800_R (800 mm, with rotational axis)

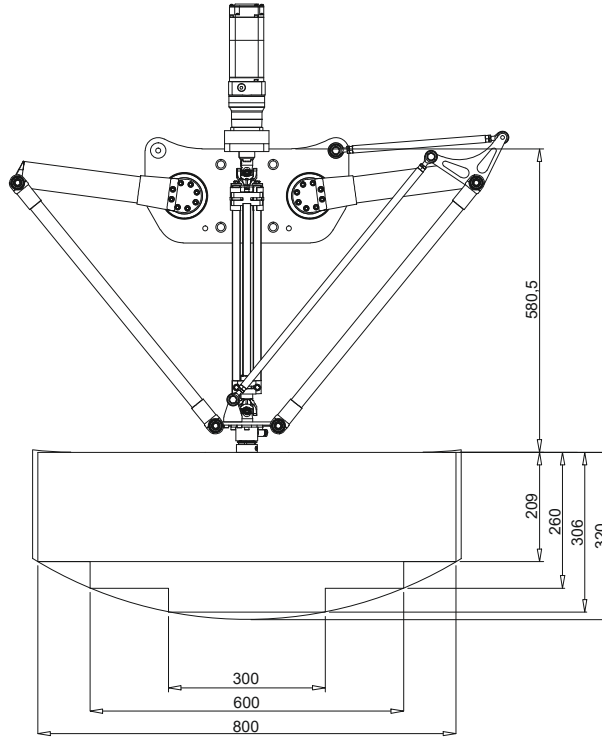

CR_UGD2800_NR (800 mm, without rotational axis)

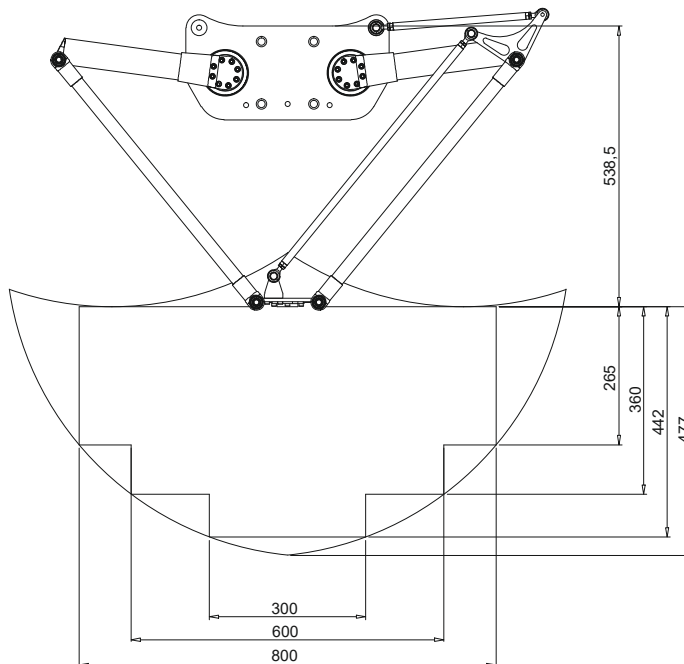

NOTE

Note that the rotation servo motor, on the top of the robot, is optional.

Chapter 3 Installation

Contents

1. Unpacking	3-1
1.1 Unpacking the shipping box	3-1
1.2 Check the damage	3-1
1.3 Lifting and transportation	3-2
2. Mounting the robot	3-3
3. Calibration (Robots with serial number 2264 or higher)	3-4
4. Calibration (Robots with serial number 2263 or lower)	3-6
5. Gripper interface	3-9

1. Unpacking

1.1 Unpacking the shipping box

The robot comes in a special shipping box.

The following step must be carried out to remove the cover from the box:

- Unscrew the screws from the cover of the wooden box
- Now remove the cover

The following illustration will show you the components and their description what's in the box:

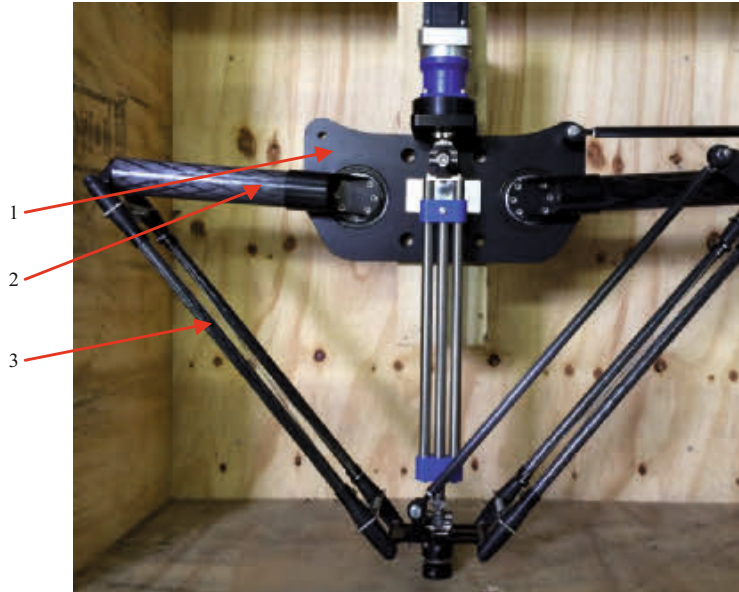

No.	Description
1	Baseplate
2	Primary arms
3	Secondary arms

1.2 Check the damage

First take out the individual components from the package and check that everything is correct. Check all the components and the robot for transportation damage.

1.3 Lifting and transportation

Before the robot is lifted, it must be ensured that it is free from obstructions. Remove all the screws where the robot is mounted with in the box.



No.	Description
1	Screws with protection material

The robot must be lifted by at least 2 persons and transported by using lifting tackle or a forklift truck. Two lifting straps can be attached around the two upper arms to lift the robot. The lifting straps has to be long enough and must be routed in such a way that the robot is not damaged.



WARNING

- THE ROBOT MAY TILT DURING TRANSPORTATION.
- ADDITIONAL SAFEGUARDING MEASURE MUST BE TAKEN.
- WEAR SUITABLE PROTECTIVE CLOTHING IF NECESSARY.
- WHEN USING A FORKLIFT TRUCK, DRIVE EXTREMELY SLOWLY AND CAREFULLY.

2. Mounting the robot

The mounting surface for the robot must be machined and of an appropriate quality. It's also possible to use a levelling element to align the robot.

Four M12 bolts are needed to mounting the robot to the frame, exact bolt length depends on frame layout. The tightening torque of a M12 8.8 bolt is 100Nm.

The below figure shows the mounting pattern from the robot.

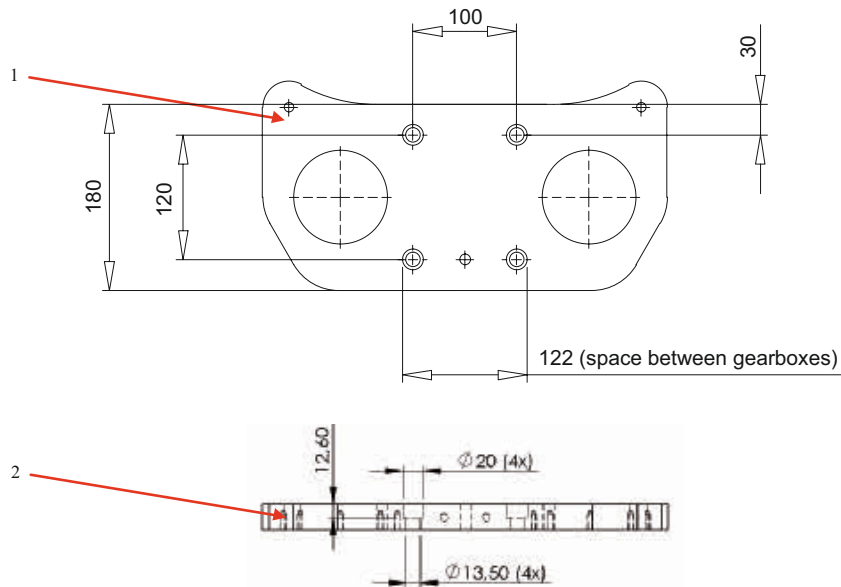

No.	Description
1	Front side baseplate
2	Cross section baseplate



WARNING

- THE ROBOT MAY HIT THE FRAME.
- THE ROBOT COULD BE DAMAGED.
- MAINTAIN THE MINIMUM CLEARANCE OF 20 mm WHEN INSTALLING THE ROBOT.

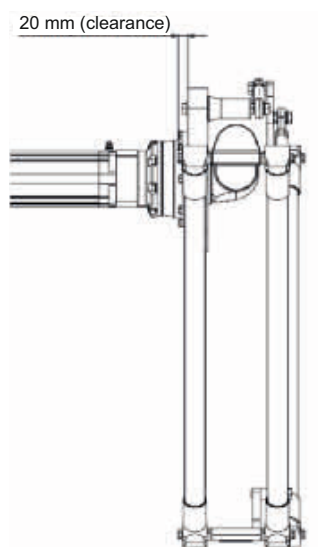

3. Calibration (Robots with serial number 2264 or higher)

No every robot that is delivered is calibrated.

If you want to calibrate the robot by yourself, a calibration tool is available (shown in the below picture).

The calibration tool can be ordered as CR_AS-2813.



No.	Description
1	Calibration tool

The following steps must be carried out to put the two upper arms from the robot in the zero position. Please see also the below pictures:

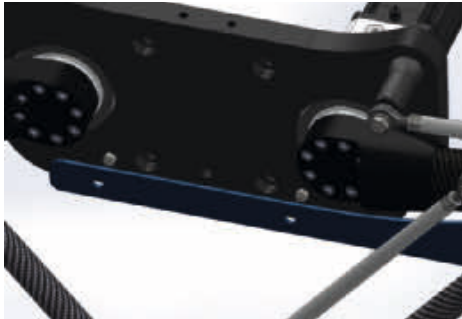

- Release the motor brake and make sure all the primary arms are rotated up far enough, so the calibration tool could be mounted
- Put the fork on the baseplate as shown in the above picture



- Now put the shaft from the primary arm into the machined hole from the calibration tool and fix the brake
- Now your first primary arm is in zero position, now turn the tool and repeat these actions for the other primary arm



WARNING

- CALIBRATING THE ROBOT MUST BE CARRIED OUT BY QUALIFIED PROGRAMMING PERSONNEL ONLY, AS THIS REQUIRES AN EXCELLENT LEVEL OF KNOWLEDGE OF THE CONTROL SYSTEM.
- WHEN CARRYING OUT THE HOMING YOURSELF, THIS MUST BE CARRIED OUT EXACTLY IN THE WAY AND THE ORDER THAT THEY ARE DESCRIBED.

- Now all the primary arms are in zero position from the kinematic model
- Now put the encoder values from the servo motors in 0°
- Check that the angle indicated for the three motors is $0^\circ (\pm 0.1^\circ)$
- Your robot is now calibrated

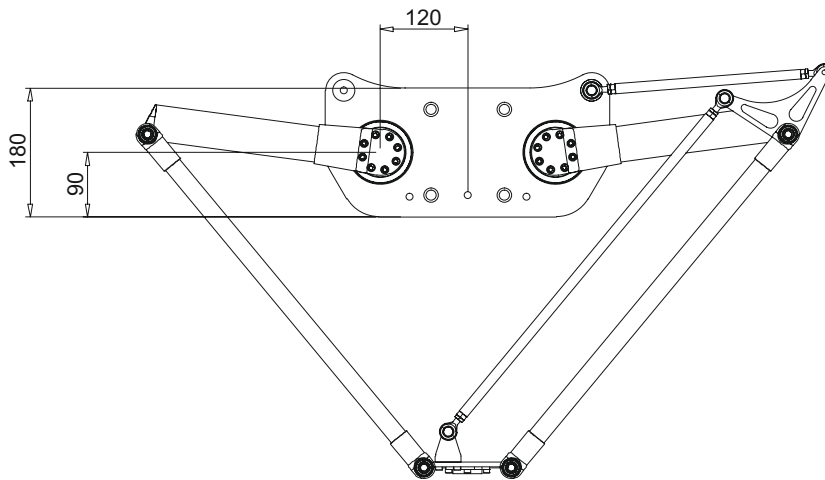

4. Calibration (Robots with serial number 2263 or lower)

No every robot that is delivered is calibrated.

If you want to calibrate the robot by yourself, a calibration tool is available.

The calibration tool can be ordered as CR_AS-2255.

The following steps must be carried out to put the three upper arms from the robot in the zero position. Please see also the below pictures:

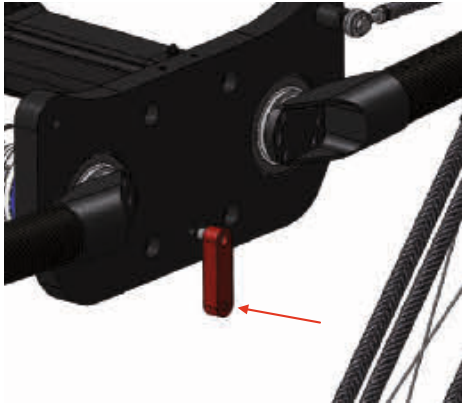

- Release the motor brake and make sure all the primary arms are rotated down far enough, so the calibration tool could be mounted
- Put the fork on the baseplate as shown in the below picture
- Now mount the adapter plate and tighten the star knob

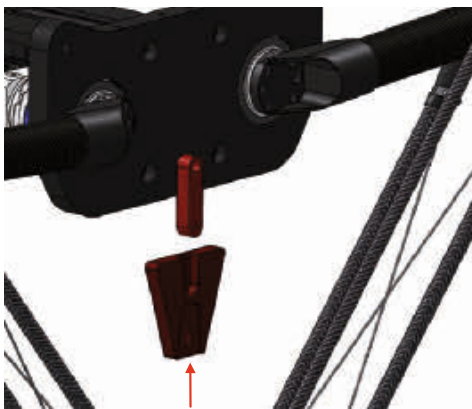

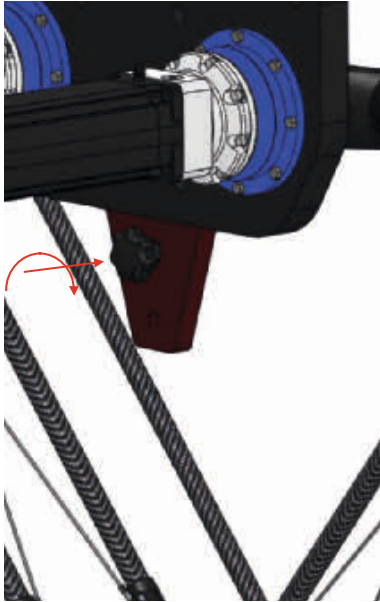

- Now mount the lower strip and the lower bracket

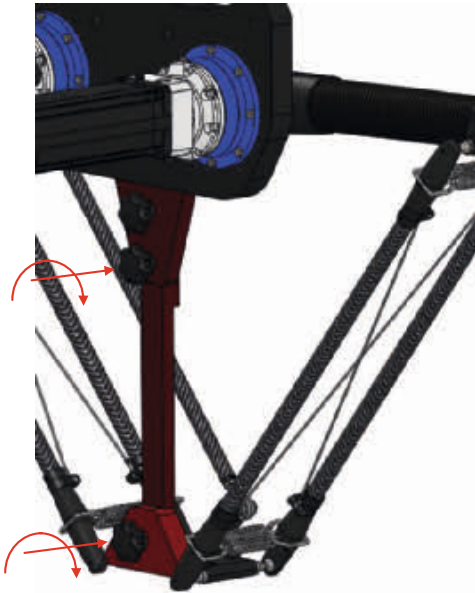

- Now your tool is installed

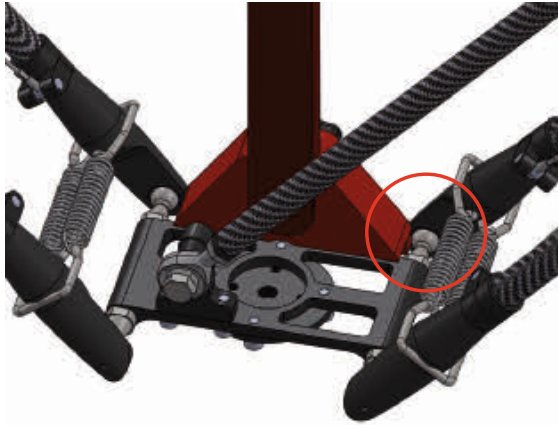

- Release the motor brake from the motors and push the TCP plate and the right ball joint against the calibration tool as shown in the above picture (please note that the upper side from the TCP has to hit the calibration tool and that the right corner from the tool has to hit the ball joint as shown in the above picture)
- Now fix the motor brake from the motors
- Remove the tool



WARNING

- CALIBRATING THE ROBOT MUST BE CARRIED OUT BY QUALIFIED PROGRAMMING PERSONNEL ONLY, AS THIS REQUIRES AN EXCELLENT LEVEL OF KNOWLEDGE OF THE CONTROL SYSTEM.
- WHEN CARRYING OUT THE HOMING YOURSELF, THIS MUST BE CARRIED OUT EXACTLY IN THE WAY AND THE ORDER THAT THEY ARE DESCRIBED.

- Now all the primary arms are in zero position from the kinematic model
- Now put the encoder values from the servo motors in 0°
- Check that the angle indicated for the three motors is $0^\circ (\pm 0.1^\circ)$
- Your robot is now calibrated

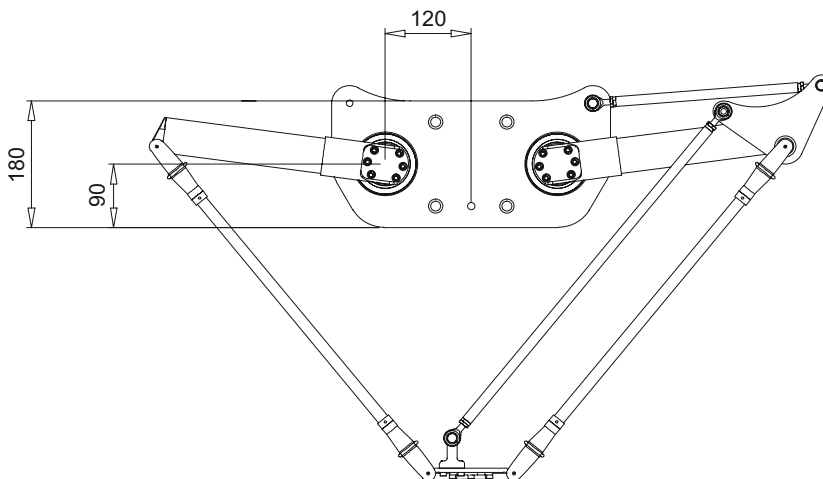

5. Gripper interface

The below picture shows you the gripper connection sizes according to ISO 9409-1-A31,5. The gripper connection sizes for the robot with or without rotational axis are the same.

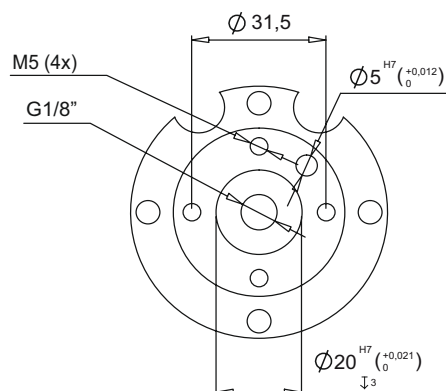

The design of the gripper that is mounted under the robot have great influence on the performance of the robot. Both the weight of the gripper and the distance of the center of gravity of the gripper to the TCP base point have negative influence on the final performance of the robot.

If you need to install cabling for the gripper, please follow the following steps:

- Mount the cables on the baseplate or frame, near the turning point from the primary arm on the gearbox
- Mount the cables on the primary arm, with ty-raps or clamping parts
- Keep a big loop at the hinge point from the primary and secondary arm
- Mount the cables on the secondary arm, with ty-raps or clamping parts
- Keep a big loop from the lowest mounting point at the secondary arm till the connection on the gripper
- Pneumatic correction devices or centring fixtures on the gripper must work in both directions. Non-symmetrical mechanisms can cause vibration in the robot mechanics



Chapter 4 Maintenance

Contents

1. Periodic maintenance (Robots with serial number 2264 or higher)	4-1
1.1 Removing the secondary arms	4-1
1.2 Mounting the secondary arms	4-2
1.3 Rotational axis	4-2
2. Periodic maintenance (Robots with serial number 2263 or lower)	4-4
2.1 Removing the secondary arms	4-4
2.2 Mounting the secondary arms	4-5
2.3 Rotational axis	4-6
2.4 Springs	4-7
2.5 Ball bearing cups	4-7
3. Cleaning the robot	4-8
4. Spare parts	4-8

1. Periodic maintenance (Robots with serial number 2264 or higher)

Before working on the robot, please be ensured that the machine where the robot is built in, is totally switched off.



DANGER

- SWITCH OFF THE MACHINE (SYSTEM) WHERE THE ROBOT IS BUILT IN (E.G. WITH A PADLOCK) TO PREVENT IT FROM BEING SWITCHED ON AGAIN.
- LABEL THE MACHINE (SYSTEM) WITH A SIGN INDICATION THAT WORK IS IN PROGRESS. THIS SIGN MUST REMAIN IN PLACE, EVEN DURING TEMPORARY INTERRUPTIONS TO THE WORK.
- THE EMERGENCY STOP FROM THE MACHINE (SYSTEM) MUST REMAIN ACTIVE. IF SAFETY FUNCTIONS OR SAFEGUARDS ARE DEACTIVATED DURING MAINTENANCE OR REPAIR WORK, THEY MUST BE REACTIVATED IMMEDIATELY AFTER THE WORK IS COMPLETED.

1.1 Removing the secondary arms

The following steps must be carried out to remove the secondary arms from the robot. Before you start, please put the robot in zero position. Please, see also the below pictures.

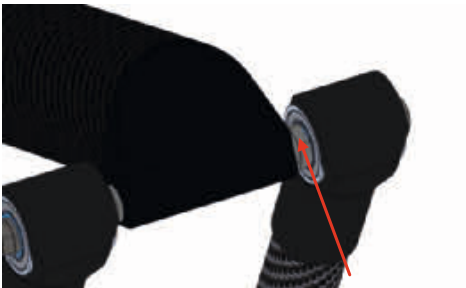

- Release the arm shaft by unscrewing the 2 x 12 mm shaft connections (upper arm and TCP plate)
- Please, do this at the same time to prevent damage from the thread



1.2 Mounting the secondary arms

The following steps must be carried out to re-assemble the secondary arms from the robot. Before you start, please put the robot in zero position.

- Put Loctite 243 on the thread ends
- Mount the arm on the primary arm and the TCP plate
- Please, do this at the same time to prevent damage from the thread
- Tighten the 2 thread ends with 12Nm

1.3 Rotational axis

The plain bearings on the rotational axis wear with time so that backlash starts to occur on the rotational axis. How fast the plain bearings become worn depends strongly on the following factors:

- The working path
- The payload
- The speed of the robot
- The rotation actions

When do I have to exchange the plain bearings?

- If there is a lot of play on the rotational axis
- Every 3000 working hours or once a year

For instructions to replace the plain bearings, see the below picture:

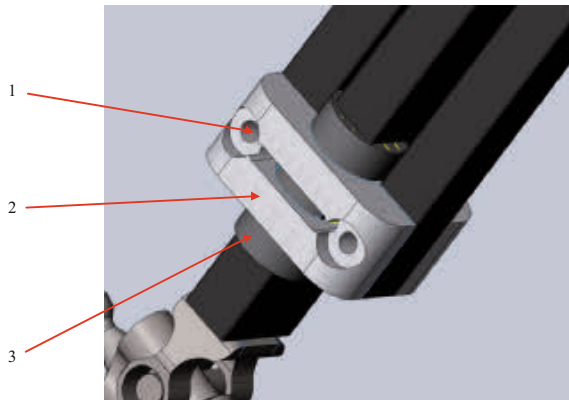

No.	Description
1	M5 bolt with washer
2	Slider clamp bottom
3	Plain bearing

- Unscrew the two M5 bolts with washer and take of the slider clamp bottom
- Now exchange the old bearing with a new one
- Put back the slider clamp bottom and the two M5 bolts with washer
- Repeat this for the other side of the axis

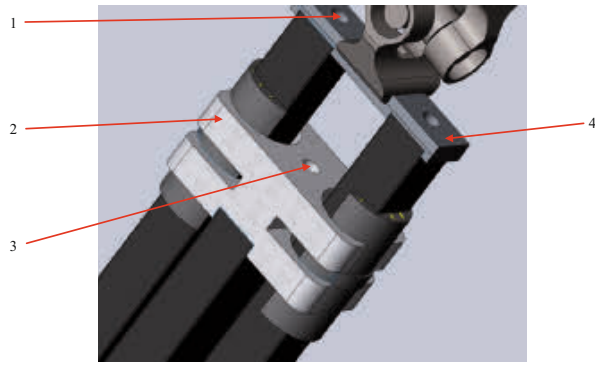

No.	Description
1	2 x M5 bolt with washer
2	Slider clamp top
3	1 x M5 bolt with washer
4	Top connector

- Unscrew the two M5 bolts with washer from the connector and the slider clamp top
- Remove the top connector from the tubes
- Remove the slider clamp top with the plain bearings
- Now exchange the old plain bearings with the new ones
- Put back the slider clamp top and the M5 bolt with washer
- Mount the top connector with the two M5 bolts with washer on the two tubes



WARNING

- PLAIN BEARINGS HAS TO BE MOUNTED VERY CAREFULLY.
- WRONG MOUNTED PLAIN BEARINGS MAY DAMAGE.
- EXTEND THE ROTATIONAL AXIS TO ITS ENTIRE LENGTH, THEN RETRACT THE SAME AND CHECK WHETHER IT IS EASY TO OPERATE OR WHETHER SOME RESISTANCE OCCURS.

2. Periodic maintenance (Robots with serial number 2263 or lower)

Before working on the robot, please be ensured that the machine where the robot is built in, is totally switched off.



DANGER

- SWITCH OFF THE MACHINE (SYSTEM) WHERE THE ROBOT IS BUILT IN (E.G. WITH A PADLOCK) TO PREVENT IT FROM BEING SWITCHED ON AGAIN.
- LABEL THE MACHINE (SYSTEM) WITH A SIGN INDICATION THAT WORK IS IN PROGRESS. THIS SIGN MUST REMAIN IN PLACE, EVEN DURING TEMPORARY INTERRUPTIONS TO THE WORK.
- THE EMERGENCY STOP FROM THE MACHINE (SYSTEM) MUST REMAIN ACTIVE. IF SAFETY FUNCTIONS OR SAFEGUARDS ARE DEACTIVATED DURING MAINTENANCE OR REPAIR WORK, THEY MUST BE REACTIVATED IMMEDIATELY AFTER THE WORK IS COMPLETED.

2.1 Removing the secondary arms

The following steps must be carried out to remove the secondary arms from the robot. Before you start, please put the robot in zero position. Please see also the following pictures:



No.	Description
1	2 x wires

- Remove the 2 indicated wires from the lower arms



- Now you can take of the secondary arm set as shown in the next picture

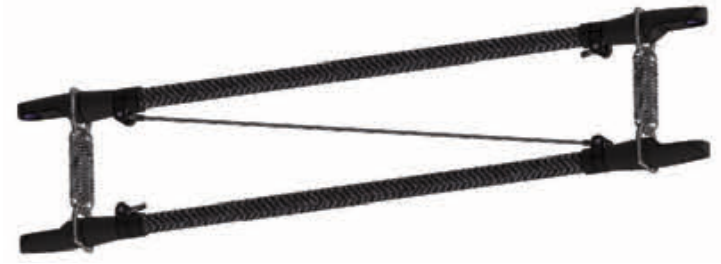

2.2 Mounting the secondary arms

The following steps must be carried out to re-assemble the secondary arms from the robot. Before you start, please put the robot in zero position. Please see also the following pictures:



- Now mount the secondary arms on the robot the same way as you remove them
- When the arms are mounted you have to put back the two wires which are removed during the demounting (do not tighten them)
- Now install the calibration tool by following **Section 4 Calibration (Robots with serial number 2263 or lower)** in Chapter 3 till the tool is installed
- Tighten the two remounted wires till the TCP plate hits the tool again
- Now tighten the wires one by one and keep the TCP plate in line with the calibration tool. Every time when you have tighten 4 wires, please check the stability of the TCP by push and pull it back and forth (see below picture)
- To check if the arms are corrected tensioned, you have to pull at the TCP in the direction as shown in the below picture. You have to pull with an torque of 30 N and then the movement may be maximum 1 mm



2.3 Rotational axis

The plain bearings on the rotational axis wear with time so that backlash starts to occur on the rotational axis. How fast the plain bearings become worn depends strongly on the following factors:

- The working path
- The payload
- The speed of the robot
- The rotation actions

When do I have to exchange the plain bearings?

- If there is a lot of play on the rotational axis
- Every 3000 working hours or once a year

For instructions to replace the plain bearings, see the below picture:

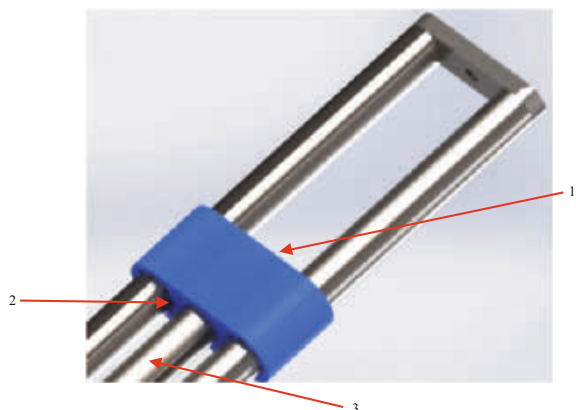

No.	Description
1	M5 bolt with washer
2	Plain bearing
3	Lower rotation tube

- Unscrew the M5 bolt with washer from the upper bearing block
- Remove the lower rotation tube

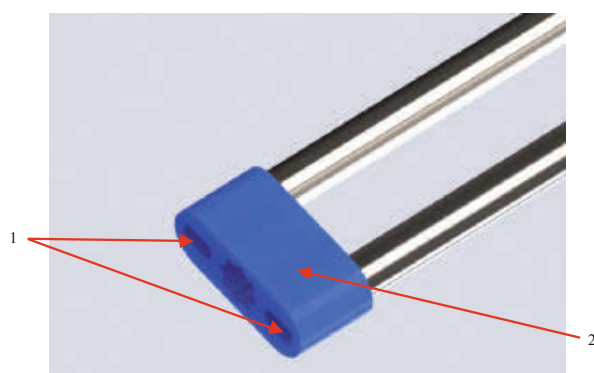

No.	Description
1	2 x M5 bolt with washer
2	Lower plain bearing

- Unscrew the two M5 bolts with washer and take of the old lower and upper plain bearing blocks
- Exchange the three yellow plain bearings with the new ones
- Now put the upper bearing block on the tubes
- Put back the lower bearing block and the 2 x M5 bolt with washer

- Tighten the 2 x M5 bolt
- Now put back the lower rotation tube and mount it with the M5 bolt with washer
- Tighten the M5 bolt



WARNING

- PLAIN BEARINGS HAS TO BE MOUNTED VERY CAREFULLY.
- WRONG MOUNTED PLAIN BEARINGS MAY DAMAGE.
- EXTEND THE ROTATIONAL AXIS TO ITS ENTIRE LENGTH, THEN RETRACT THE SAME AND CHECK WHETHER IT IS EASY TO OPERATE OR WHETHER SOME RESISTANCE OCCURS.

2.4 Springs

How to maintain the springs:

- The springs has to be replaced every 3800 working hours or once a year
- When the robot is fall apart, check the springs on damages
- Only use springs delivered by OMRON, otherwise the guarantee will expire
- Replace springs after overstretching
- For spare parts, see **Section 4 Spare parts** in this chapter



WARNING

- INCORRECT MOUNTED SPRINGS CAN JUMP AWAY.
- WEAR SUITABLE PROTECTIVE CLOTHING AND SAFETY GLASSES.
- NEVER PULL THE SPRINGS FURTHER APART THAN NECESSARY WHEN MOUNTING THE ARM ASSEMBLY ON THE PRIMARY ARM OR TCP BALL JOINTS.

How to disassemble the springs:

- Disassemble the secondary arms from the robot
- Replace the springs
- For re-assembling the secondary arms, see **Section 2.2 Mounting the secondary arms** in this chapter

2.5 Ball bearing cups

The ball bearing cups has the same lifetime as the springs. We recommend to exchange these at the same time as the springs.

How to maintain the ball bearing cups:

- The ball bearing cups has to be replaced every 3800 working hours or once a year
- When the ball bearing cups make squeaking noises, take of the secondary arm assembly's and clean the cups with pressed air
- **Do not lubricate the ball bearing cups!**

For instructions to replace the ball bearing cups, see the below picture:

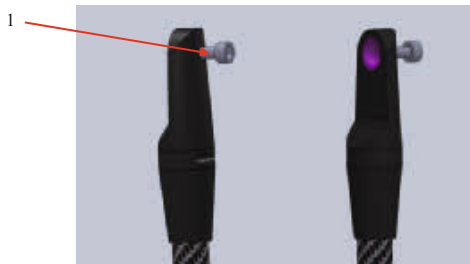

No.	Description
1	M5 bolt

- Screw an M5 bolt in the backside from the cup holder
- Now the ball bearing cup will come out

3. Cleaning the robot













Clean the robot by washing with soft cloth or sponge. Use soap or mild detergent and warm water followed by clear water rinse.

For oil and grease stains use alcohol with soft cloth.











Do not use a high pressure water cleaner, or any other high pressure cleaning device.

4. Spare parts

- Robots with serial number 2264 or higher
Common spare parts (models with/without rotational axis)

Robot part	Description	Quantity per robot	OMRON Part No.
			CR_UGD2800_[]
Primary arm	1 x primary arm left	1	CR_AS-2609 
	1 x primary arm right	1	CR_AS-2608 
Secondary arm	1 x secondary arm	3	CR_AS-2611 
	1 x secondary arm with wishbone	1	CR_AS-3185 
	1 x reaction rod	1	CR_LS-1069 
	1 x bearing 1	16	CR_CP-1039 
	1 x bearing 6 for wishbone	2	CR_CP-1022 
Primary arm & Secondary arm	1 x rod end bearing M8 L	2	CR_AS-2965 
	1 x rod end bearing M8 R	2	CR_AS-2964 
	1 x reaction rod	1	CR_LS-1068 
TCP - Tool Center Point	1 x TCP	1	CR_AS-2612 
Gearbox for primary arm	1 x gearbox	2	CR_GEARP-16 
Calibration tool	1 x calibration tool	1	CR_AS-2813 

Spare parts for models with rotational axis

Robot part	Description	Quantity per robot	OMRON Part No.
			CR_UGD2800_R
Rotational axis	1 x bearing 2	2	CR_CP-1026 
	1 x gripper flange	1	CR_AS-2934 
	1 x cardan joint	2	CR_AS-2290 
	1 x mounting clamp with cardan joint	1	CR_AS-2938 
	1 x complete rotational axis with TCP and mounting clamp	1	CR_AS-2988 
	1 x upper side rotational axis	1	CR_AS-2987 
	1 x lower tube with cardan joint and TCP	1	CR_AS-2968 
	1 x plain bearing	4	CR_CP-1000 
Gearbox for rotational axis	1 x gearbox	1	CR_GEARP-14 
TCP - Tool Center Point	TCP	1	CR_AS-2612 

Spare parts for models without rotational axis

Robot part	Description	Quantity per robot	OMRON Part No.
			CR_UGD2800_NR
TCP - Tool Center Point	1 x gripper flange	1	CR_PT-05418 

- Robots with serial number 2263 or lower
Common spare parts (models with/without rotational axis)

Robot part	Description	Quantity per robot	OMRON Part No.
			CR_UGD2800_[]
Secondary arm	2 x secondary arm	2	CR_AS-2142
	2 x wires including nuts		
	2 x springs		
	1 x reaction rod	1	CR_LS-1069
	1 x spring package	4	CR_AS-00312-1
	1 x ball bearing cup	8	CR_PT-01841-3
Primary arm & Secondary arm	2 x wires	2	CR_AS-3179
	4 x nuts		
	1 x rod end bearing M8 L	2	CR_AS-2965
	1 x rod end bearing M8 R	2	CR_AS-2964
	1 x reaction rod	1	CR_LS-1068
Gearbox for primary arm	1 x gearbox	2	CR_GEARP-16
Gearbox for rotational axis	1 x gearbox	1	CR_GEARP-14
Calibration tool	1 x calibration tool	1	CR_AS-2255



NOTE _____
For other spare part items, please contact your Omron representative.

Chapter 5 Robot settings

Contents

1. Kinematics	5-1
2. Workspace	5-2
3. Software limits	5-3

1. Kinematics

The kinematics parameters for the CR_UGD2800 robot are shown below. Set these parameters corresponding to the controller settings.



WARNING

IF THE KINEMATICS PARAMETERS ARE NOT SET PROPERLY, THIS MAY CAUSE THE ROBOT TO MALFUNCTION. SO, BE SURE TO SET THESE PARAMETERS CORRECTLY.

Kinematics parameters

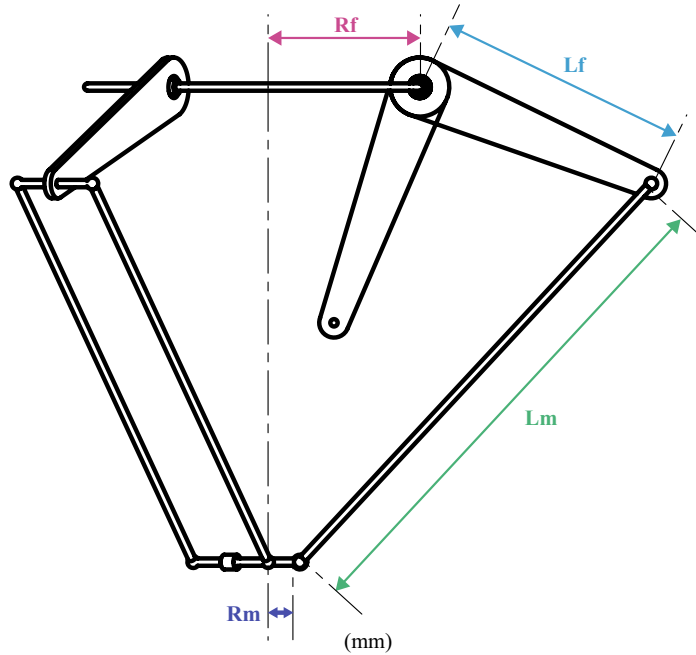

- Rf:** 120 mm Distance (radius) from the center of the fixed frame to the motor of the axis
- Rm:** 60 mm Distance (radius) from the center of the moving frame to the connection point of Link 2
- Lf:** 320 mm Length of Link 1
- Lm:** 600 mm Length of Link 2

2. Workspace

The workspace parameters for the CR_UGD2800 robot are shown below. Set these parameters corresponding to the controller settings.



WARNING

IF THE WORKSPACE PARAMETERS ARE NOT SET PROPERLY, THIS MAY CAUSE THE ROBOT TO MALFUNCTION. SO, BE SURE TO SET THESE PARAMETERS CORRECTLY.

Workspace parameters

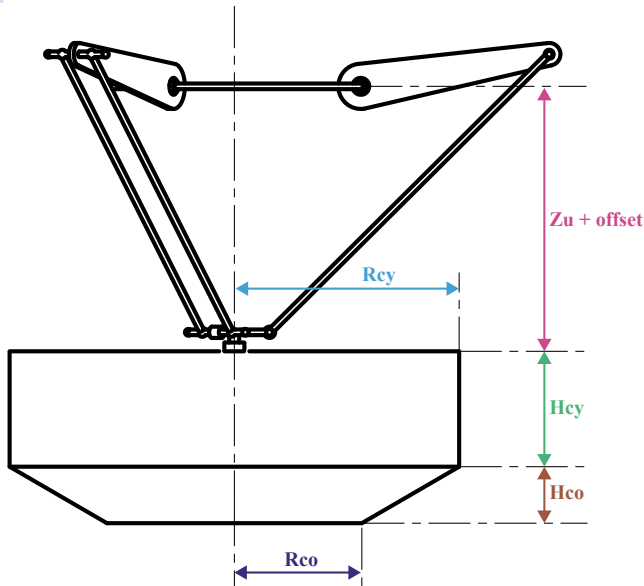

Zu + offset: -490,5 mm with rotational axis / -448,5 mm without rotational axis Distance from the Z-axis origin position to the tool flange

Rcy: 400 mm Radius of the cylinder

Hcy: 209 mm with rotational axis / 265 mm without rotational axis Height of the cylinder

Rco: Refer to "2. External view and dimensions" in Chapter 6 for detailed information about Rco parameter.

Hco: Refer to "2. External view and dimensions" in Chapter 6 for detailed information about Hco parameter.

3. Software limits

The software limits for the CR_UGD2800 robot are shown below.



WARNING

IF THE α -, β - OR γ - AXIS SOFT LIMIT IS SET INCORRECTLY, THE ARM MAY COLLIDE WITH THE ROBOT BASE OR BASE PREPARED BY THE USER, CAUSING BREAKAGE. SO, BE SURE TO SET THE SOFT LIMITS CORRECTLY.

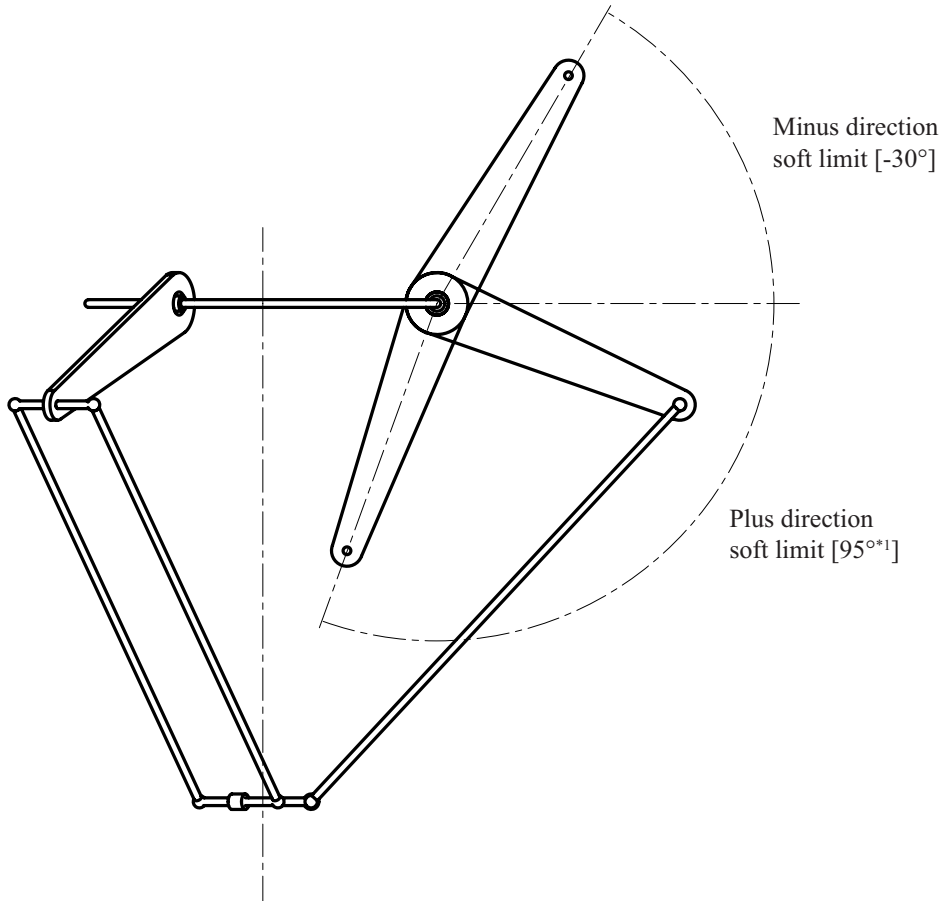

*1. For the robots ordered before September 2023, the Positive software limit is 85°.

Chapter 6 Specifications

Contents

1. Basic specifications	6-1
1.1 Cycle time	6-1
2. External view and dimensions	6-2
3. Design specifications	6-3
3.1 Occupation area of robot	6-3
3.2 Software design	6-4
3.2.1 Dimensions and limits	6-4

1. Basic specifications

Robot model		CR_UGD2800_R	CR_UGD2800_NR
Working volume	X axis	Stroke	800mm
	Z axis	Stroke	209mm (max. 800mm)
	θ axis	Rotation range	±180° (default setting, it can be changed)
Servo motor	Arm 1, 2		1000W
	Rotational axis 3		400W
Repeatability* ¹	X, Z axis		±0.3mm
	θ axis		±0.2°
Maximum through-put* ²			200 CPM* ³
Maximum payload			3kg
Gear box ratio	X, Z axis		1:31
	θ axis		1:10
θ axis torque limitation			16Nm
Travel limit			Soft limit
Noise level			< 70 dB (A)
Ambient temperature			5°C to 45°C
Relative humidity			Max. 90%
Protection class			IP65
Weight			40kg

*1: This is the value at a constant ambient temperature.

*2: With 0.1kg payload. When reciprocating 305mm in horizontal and 25mm in vertical directions.

*3: CPM: Cycle per minutes. Check the note 2 for the cycle definition.

1.1 Cycle time

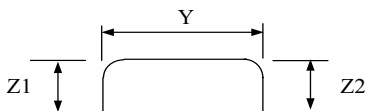

P&P path	Payload	Cycle time
25 x 305 x 25 mm (Z1 x Y x Z2)	0.1 kg	0.30 s
	0.5 kg	0.40 s
	1 kg	0.50 s
	3 kg	0.85 s

2. External view and dimensions

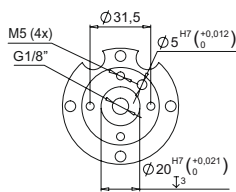
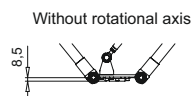
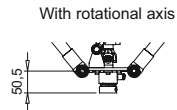
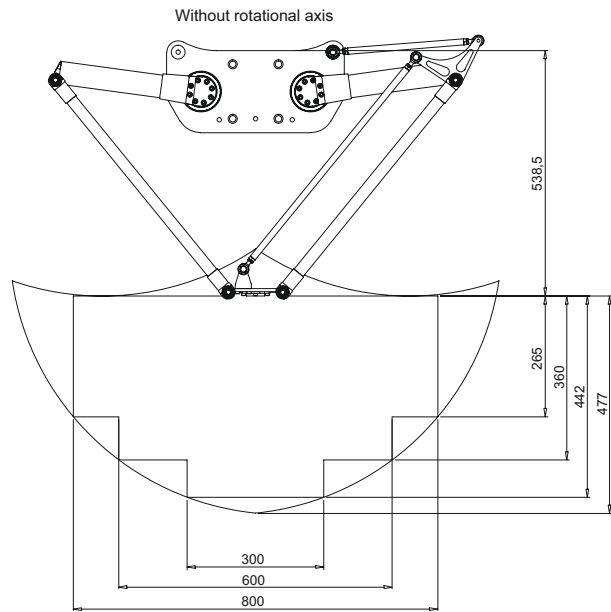
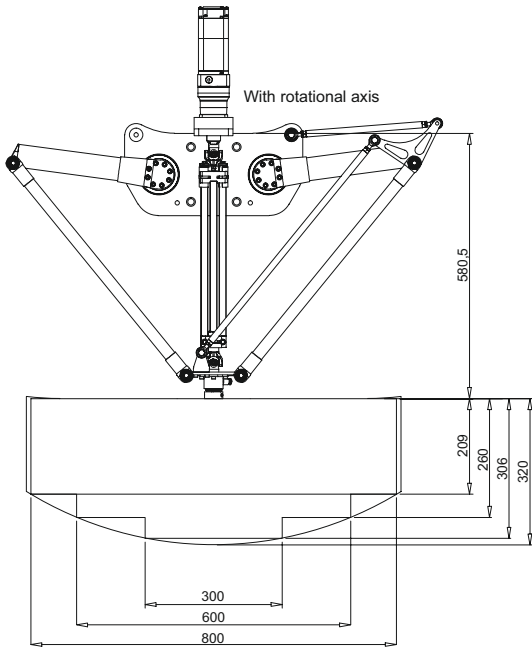
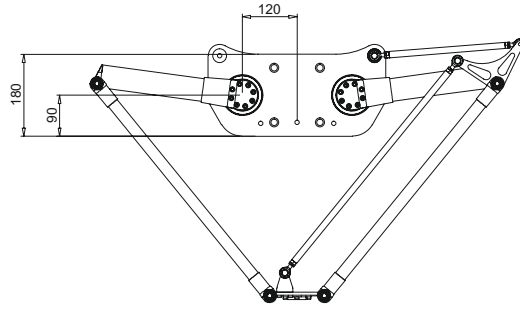
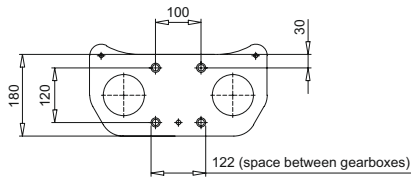

Gripper dimensions

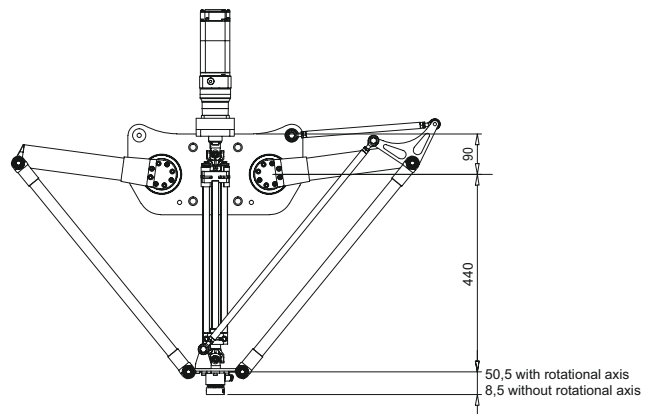

3. Design specifications

3.1 Occupation area of robot

If the robot is integrated into the machine it must be considered what the reach is of all robot parts to prevent collision with other parts in the machine.

When the TCP moves to its outer positions, the primary and secondary arms can rise above the baseplate, take care that no mechanical obstructions are in the areas indicated in the below picture.

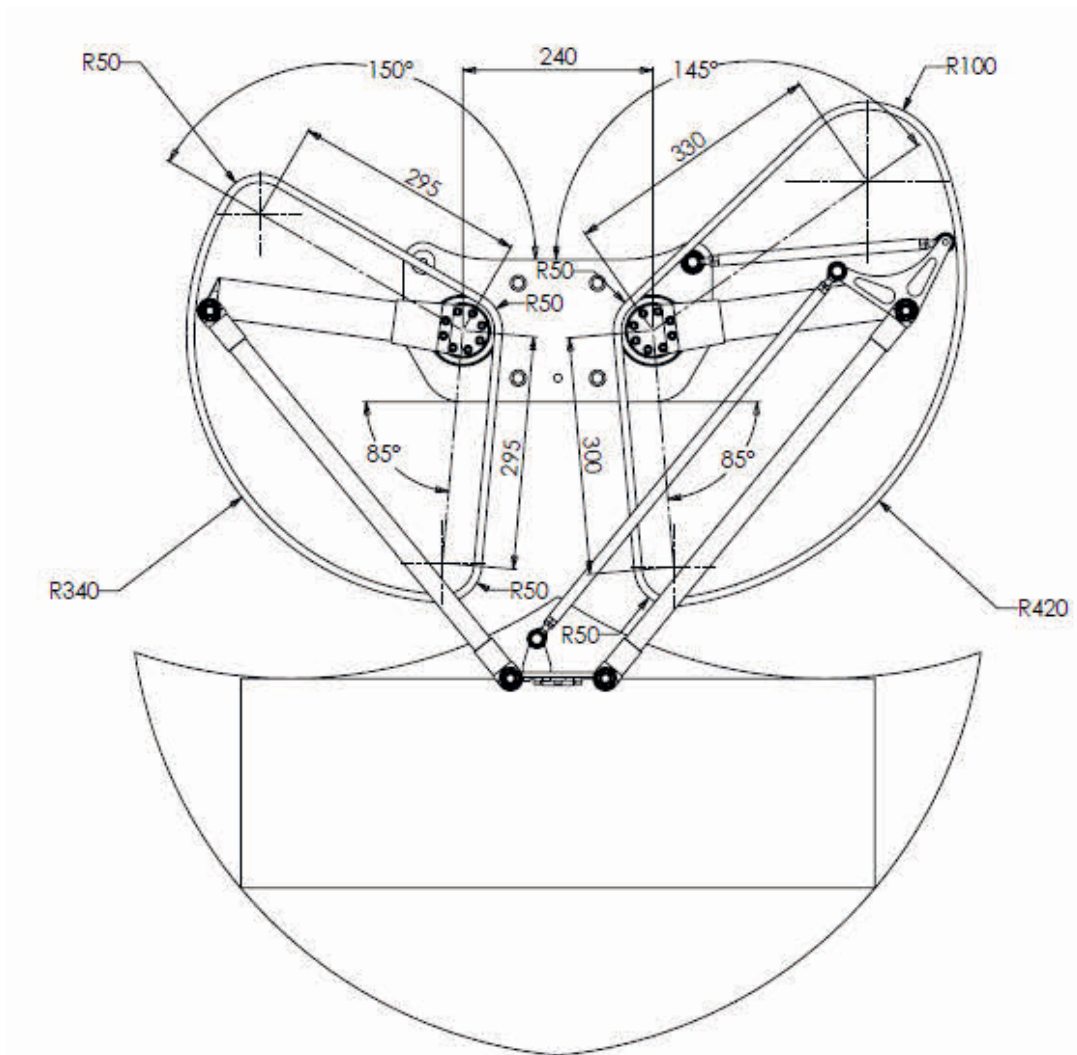

WARNING

IF MECHANICAL OBSTRUCTIONS ARE IN THE INDICATED AREAS, THE ROBOT OR THE OTHER MACHINE PARTS COULD BE DAMAGED.

3.2 Software design

The arm lengths and distance between motors are shown in the below picture.

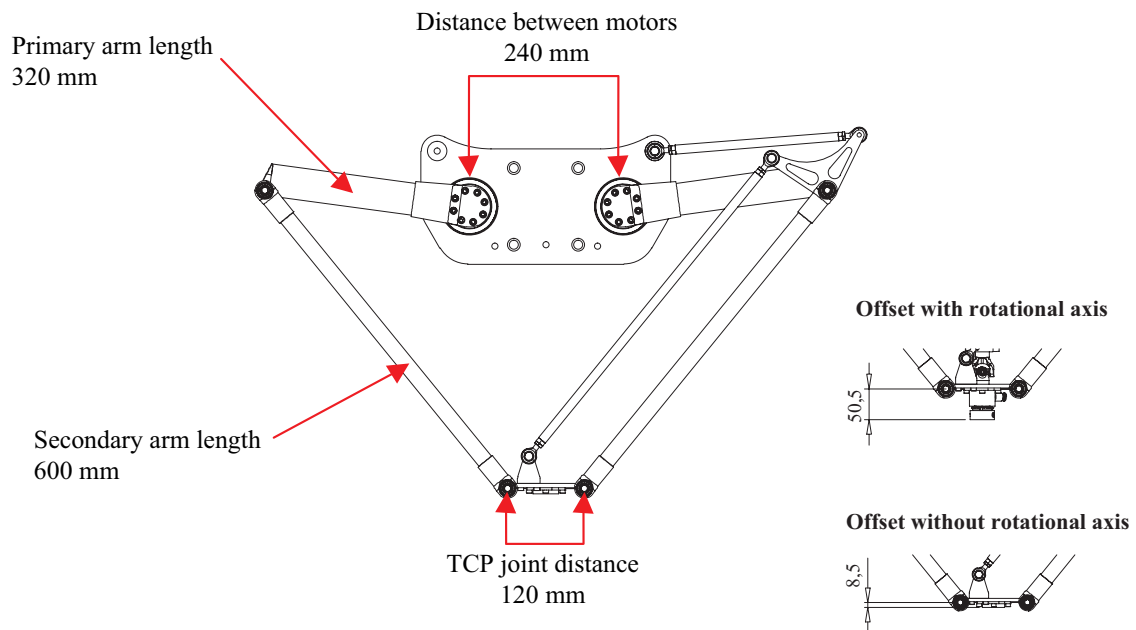

3.2.1 Dimensions and limits

Description	Value	
	With rotational axis	Without rotational axis
Negative software limit	-30°	
Positive software limit	95° ^{*1}	
Tb-z (top baseplate to zero position)	90 mm	
Z-tw (zero position to ball joints)	440 mm	
Flange offset	50,5 mm	8,5 mm

*1. For the robots ordered before September 2023, the Positive software limit is 85°.

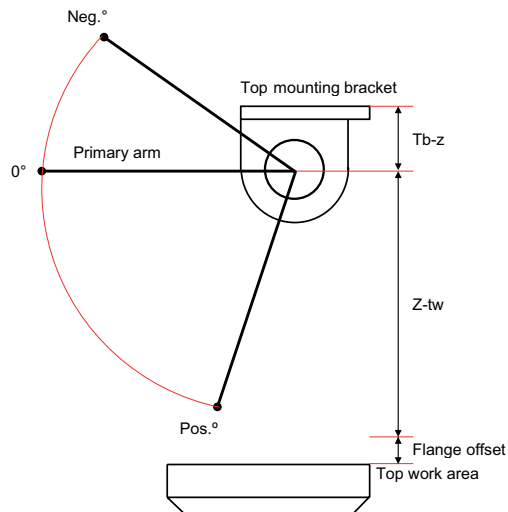

Revision history

A manual revision code appears as a suffix to the catalog number on the front cover manual.

Cat. No. I200E-EN-02A



The following table outlines the changes made to the manual during each revision.

Revision code	Date	Description
01	October 2016	Original production
01A	December 2016	Small correction
01B	January 2017	Robot dimensions were updated
01C	October 2017	Calibration section was updated. Spare parts section was updated. Robot dimensions were updated. Basic specifications section was updated
02	June 2018	Spare part references were modified
02A	June 2024	Positive limit of the robot was updated

OMRON

Authorized Distributor: