

**Delta 3+1 Robot  
IP69K protection class**

**CR\_UGD4\_HD Series**

**USER'S MANUAL**

**OMRON**



---

## Safety Instructions

---

1. Attention	S-1
2. Explanation of warnings and notes	S-1
3. Safety information	S-2
3.1 General	S-2
3.2 Qualified personnel	S-2
3.3 Liability	S-2
3.4 Installation and operating conditions	S-2
3.5 Residual risks	S-2
3.5.1 Release device	S-3
3.5.2 Transport	S-3
3.5.3 Assembly and start-up	S-3
3.5.4 Maintenance and repair	S-3
3.5.5 System integrator	S-4

---

## Chapter 1 Introduction

---

1. Introduction	1-1
1.1 Description of the robot	1-1
1.2 Type code explanation	1-1
2. Identification	1-2
3. Part names	1-2

---

## Chapter 2 Model overview

---

1. Overview	2-1
-------------	-----

---

## Chapter 3 Installation

---

1. Unpacking	3-1
1.1 Unpacking the shipping box	3-1
1.2 Check the damage	3-1
1.3 Lifting and transportation	3-1
2. Mounting the robot	3-2
3. Mounting the motors, cabling and gearbox housing	3-3
3.1 Mounting the motors	3-3
3.2 Mounting the gearbox housing into the body and connecting the cables	3-4
3.3 Mounting the covers	3-8

---

4. Assembling the secondary arms	3-9
4.1 Make an assembly	3-9
4.2 Mount the arm assembly on the robot	3-10

---

5. Mounting the rotational axis on the cardan joint	3-11
---	------

---

6. Calibration	3-12
----------------	------

---

7. Gripper interface	3-14
7.1 With rotational axis	3-14
7.2 Without rotational axis	3-14

---

## Chapter 4 Maintenance

---

1. Periodic maintenance	4-1
1.1 Springs	4-1
1.2 Ball bearing cups	4-2
1.3 Rotational axis	4-2

---

2. Cleaning the robot	4-4
-----------------------	-----

---

3. Spare parts	4-4
----------------	-----

---

## Chapter 5 Robot settings

---

1. Kinematics	5-1
---------------	-----

---

2. Workspace	5-2
--------------	-----

---

3. Software limits	5-3
--------------------	-----

---

## Chapter 6 Specifications

---

1. Basic specifications	6-1
1.1 Cycle time	6-2

---

2. External view and dimensions	6-3
2.1 CR_UGD4_XL_HD	6-3
2.2 CR_UGD4_HD	6-4
2.3 CR_UGD4_XS_HD	6-5

---

3. Design specifications	6-6
3.1 Occupation area of robot	6-6
3.2 Software design	6-7
3.2.1 Dimensions and limits	6-8

---

# Safety Instructions

## Contents

<b>1. Attention</b>	<b>S-1</b>
<b>2. Explanation of warnings and notes</b>	<b>S-1</b>
<b>3. Safety information</b>	<b>S-2</b>
<b>3.1 General</b>	<b>S-2</b>
<b>3.2 Qualified personnel</b>	<b>S-2</b>
<b>3.3 Liability</b>	<b>S-2</b>
<b>3.4 Installation and operating conditions</b>	<b>S-2</b>
<b>3.5 Residual risks</b>	<b>S-2</b>
3.5.1 Release device	S-3
3.5.2 Transport	S-3
3.5.3 Assembly and start-up	S-3
3.5.4 Maintenance and repair	S-3
3.5.5 System integrator	S-4



# 1. Attention

Information in this document can change without prior notice.

OMRON EUROPE B.V. cannot be held responsible for any damage to the environment, to the machine or to the functioning of the machine occurred by errors or missing data in the illustrations, drawing or specifications.

No part of this manual and added documentation may be copied, reproduced or translated into another language without prior written approval.

Read and understand the material contained in this user's manual before you work on the CR\_UGD4\_HD robot for the first time. This user's manual is supposed to help you use the capabilities of the CR\_UGD4\_HD robot safely and properly.

# 2. Explanation of warnings and notes

This manual uses the following safety alert symbols and signal words to provide safety instructions that must be observed and to describe handling precautions, prohibited actions, and compulsory actions. Make sure you understand the meaning of each symbol and signal word and then read this manual.

**DANGER**

THIS INDICATES AN IMMEDIATELY HAZARDOUS SITUATION WHICH, IF NOT AVOIDED, WILL RESULT IN DEATH OR SERIOUS INJURY.

**WARNING**

THIS INDICATES A POTENTIALLY HAZARDOUS SITUATION WHICH, IF NOT AVOIDED, COULD RESULT IN DEATH OR SERIOUS INJURY.

**NOTE**

Explains the key point in the operation in a simple and clear manner.

## 3. Safety information

### 3.1 General

This '3. Safety information' subchapter contains information regarding working with the CR\_UGD4\_HD robot. Qualified personnel working with the CR\_UGD4\_HD robot must have read and understood the CR\_UGD4\_HD robot documentation, including the safety information chapter.

### 3.2 Qualified personnel

These are people who, due their specialist training, knowledge and experience, and their familiarization with the relevant standards, are able to assess the work to be carried out and detect any potential hazards.

### 3.3 Liability

The CR\_UGD4\_HD robot is build using state-of-the-art technology and in accordance with the recognized safety rules. Nevertheless, misuse of the CR\_UGD4\_HD robot may constitute a risk to life and limb or cause damage to the CR\_UGD4\_HD robot and to other material property.

### 3.4 Installation and operating conditions

You may only use the components in accordance with the installation and operating conditions described in the documentation. The operating conditions at the installation location must be checked and maintained in accordance with the required technical data. Within the meaning of the Machinery Directive the CR\_UGD4\_HD robot is an incomplete machine. Commissioning is prohibited until the usable machine or system in which the CR\_UGD4\_HD robot is installed meets all requirements of the Machine directive 2006/42/EC.

For the CR\_UGD4\_HD robot you have to observe the following standards, directives and regulations:

- EN ISO 10218-1:2011 Robots and robotic devices - Safety requirements for industrial robots - Part 1: Robots.
- EN ISO 10218-1:2011 Robots and robotic devices - Safety requirements for industrial robots - Part 2: Robot systems and integration.

### 3.5 Residual risks

Safety and health risks arising from the robot mechanics have been reduced by means of safety technology and design engineering. However a residual risk remains, since the robot mechanics will be move by an automated control system.

The following are typical warnings concerning residual risks which cannot be assigned to a specific action. The expression of safety labels is identical to the safety information.

### 3.5.1 Release device

---

The robot mechanics are not supplied with an release switch to control the brakes of the motors.

**WARNING**

- MOUNT A RELEASE SWITCH ON THE MACHINE SO THE ARMS (MOTOR) OF THE ROBOT COULD BE MANUALLY MOVED.
  - MOVING AN AXIS WITH AN IMPROPERLY WORKING RELEASE SWITCH CAN DAMAGE THE MOTOR BRAKE. THIS CAN RESULT IN PERSONAL INJURY AND MATERIAL DAMAGE.
  - BEFORE RELEASING THE BRAKE, YOU HAVE TO BE SURE THAT NO ONE IS IN THE HAZARD AREA OF THE ROBOT.
- 

### 3.5.2 Transport

---

The prescribed transport position of the robot must be observed. Transportation must be carried out in accordance with the transportation instructions or assembly instructions of the robot.

**WARNING**

- ONLY USE AUTHORIZED HANDLING EQUIPMENT WITH A SUFFICIENT LOAD-BEARING CAPACITY TO TRANSPORT THE ROBOT.
  - WEAR SUITABLE PROTECTIVE CLOTHING IF NECESSARY.
- 

### 3.5.3 Assembly and start-up

---

Before starting up systems and devices for the first time, a check must be carried out to ensure that the system and devices are completed and operational, that they can be operated safely and that any damage is detected.

The valid national or regional work safety regulations must be observed for this check. The correct functioning of all safety circuits must also be tested.

The following tests must be carried out before start-up and recommissioning. It must be ensured that:

- The robot is correctly installed and fastened in accordance with the specifications in the assembly instructions.
- There are no foreign bodies or loose parts on the robot.
- All required safety equipment is correctly installed and operational.

**WARNING**

- A WRONG INSTALLED ROBOT MAY THROW OFF HIS ARMS.
  - WEAR SUITABLE PROTECTIVE CLOTHING IF NECESSARY.
- 

### 3.5.4 Maintenance and repair

---

After maintenance and repair work, checks must be carried out to ensure the required safety level. The valid national or regional work safety regulations must be observed for this check. The correct functioning of all safety circuits must also be tested.

The purpose of maintenance and repair work is to ensure that the system is kept original or, in the event of a fault, to return the system to an operational state. Repair work includes troubleshooting in addition to the actual repair itself.

The following safety measures must be carried out when working on the robot:

- Switch of the machine (system) where the robot is built-in (e.g. with a padlock) to prevent it from being switched on again
- Label the machine (system) with a sign indication that work is in progress. This sign must remain in place, even during temporary interruptions to the work.
- The emergency stop from the machine (system) must remain active. If safety functions or safeguards are deactivated during maintenance or repair work, they must be reactivated immediately after the work is completed.

### 3.5.5 System integrator

---

The robot is safely integrated into a complete system by the system integrator. The system integrator is responsible for the following tasks:

- Installing the robot
- Performing risk assessment
- Implementing the required safety functions and safeguards
- Issuing the declaration of conformity
- Attaching the CE mark
- Creating the operating instructions for the complete system

# Chapter 1 Introduction

## Contents

<b>1. Introduction</b>	<b>1-1</b>
1.1 Description of the robot	1-1
1.2 Type code explanation	1-1
<b>2. Identification</b>	<b>1-2</b>
<b>3. Part names</b>	<b>1-2</b>



# 1. Introduction

Congratulations with the purchase of your high speed Delta robot IP69K. This is a high speed pick and place robot which uses state-of-the-art stainless steel materials and the latest servo drive technology to be put in use in the most demanding pick and place applications.

This manual should be read before the commissioning of the robot. By mechanical engineers in the design phase during the integration of the robot in the machine and by software engineers to check the performance envelope of the robot.

This manual describes the main versions of the CR\_UGD4\_HD robot, and all options. Where applicable check the appropriate data for your robot type, the type can be found on the identification tag of the robot.



## 1.1 Description of the robot

The CR\_UGD4\_HD Delta robot is a high speed pick and place robot which uses state-of-the-art stainless steel materials and the latest servo drive technology to be put in use in the most demanding pick and place applications. The robot is designed as a 3-axis (optional 4th rotational axis) Delta kinematic system.

Characteristics of the robot:

- Requires very low maintenance
- 3 + 1 (rotational axis optional) degrees of freedom
- Compact design for mounting in a machine
- Low noise level < 68 dB (A)
- Equipped with special Delta robot gearboxes
- IP69K protection class

## 1.2 Type code explanation

CR\_UGD4\_XL\_R\_HD: 3 + 1 axes (with rotational axis), 1300 mm working range, max. payload: 2 kg  
CR\_UGD4\_XL\_NR\_HD: 3 axes (without rotational axis), 1300 mm working range, max. payload: 2 kg  
CR\_UGD4\_R\_HD: 3 + 1 axes (with rotational axis), 1100 mm working range, max. payload: 2 kg  
CR\_UGD4\_NR\_HD: 3 axes (without rotational axis), 1100 mm working range, max. payload: 2 kg  
CR\_UGD4\_XS\_R\_HD: 3 + 1 axes (with rotational axis), 650 mm working range, max. payload: 2 kg  
CR\_UGD4\_XS\_NR\_HD: 3 axes (without rotational axis), 650 mm working range, max. payload: 2 kg

## 2. Identification

On the robot base plate an identification tag is mounted, important data on this plate:

- Robot type
- Total weight of the robot
- Year of production
- Serial number, important for ordering spareparts

## 3. Part names

### CR\_UGD4\_HD

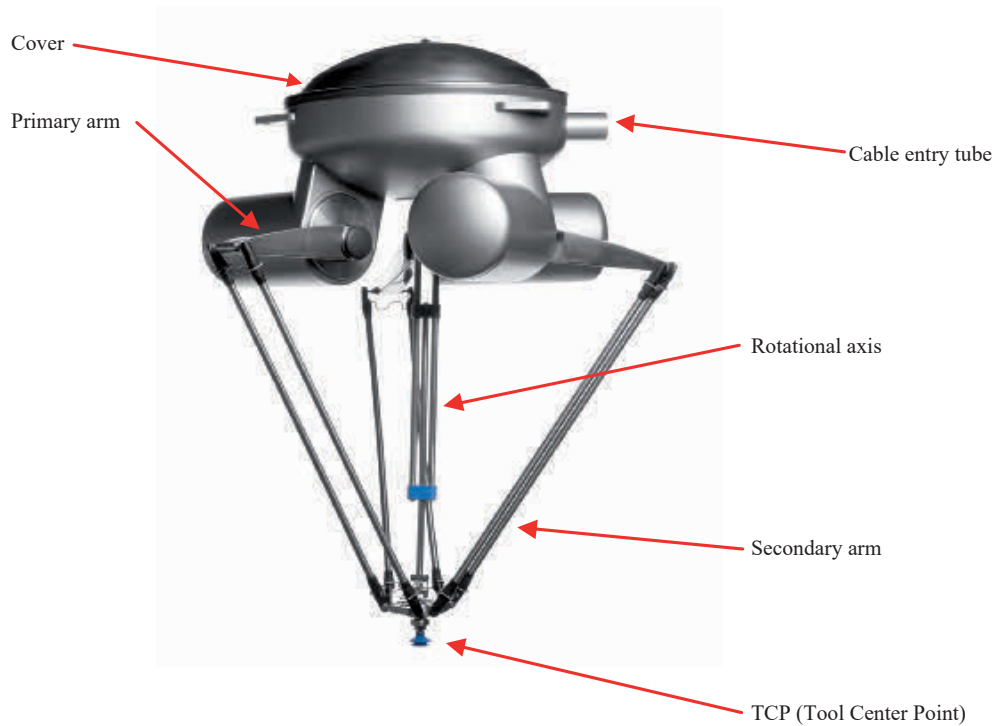

The CR\_UGD4\_HD robot consists of three radially placed axis which give the TCP freedom to move in three directions, X, Y and Z. An optional fourth axis can take care of the rotation,  $R_z$ , of the TCP.

Optionally the robot is equipped with an extra servo motor for the rotational axis.

## Chapter 2 Model overview

### Contents

1. Overview

2-1



# 1. Overview

The specifications are given in the below figure, if specifications differ for models, for instance with or without rotational axis, it is indicated in the specification list. The Delta robot is delivered standard with IP69K protection.

## CR\_UGD4\_XL\_HD (1300 mm)

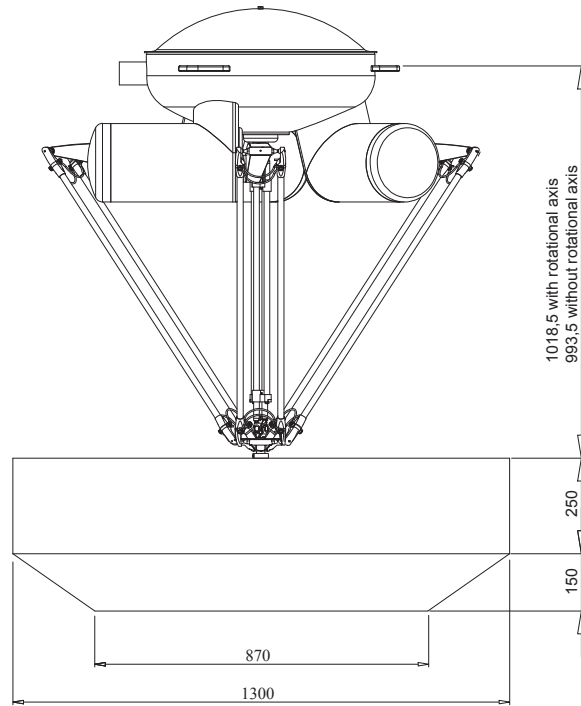

## CR\_UGD4\_HD (1100 mm)

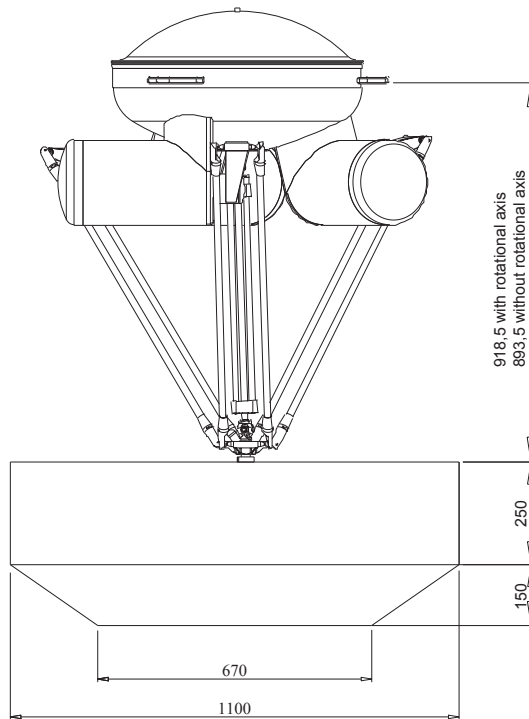

CR\_UGD4\_XS\_HD (650 mm)

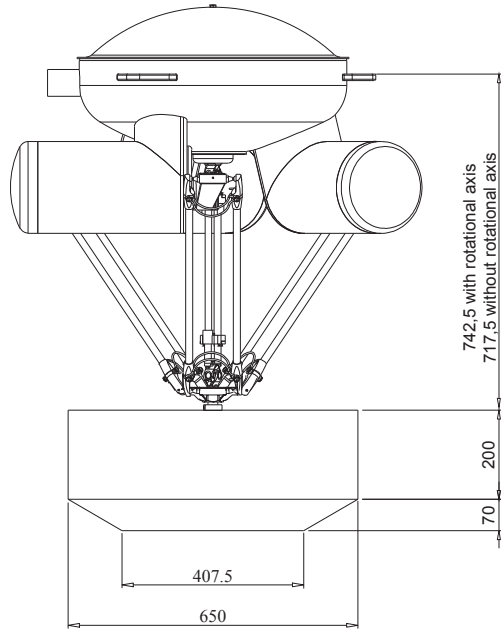

NOTE

Note that the rotation servo motor, on the top of the robot, is optional.

# Chapter 3 Installation

## Contents

<b>1. Unpacking</b>	<b>3-1</b>
1.1 Unpacking the shipping box	3-1
1.2 Check the damage	3-1
1.3 Lifting and transportation	3-1
<b>2. Mounting the robot</b>	<b>3-2</b>
<b>3. Mounting the motors, cabling and gearbox housing</b>	<b>3-3</b>
3.1 Mounting the motors	3-3
3.2 Mounting the gearbox housing into the body and connecting the cables	3-4
3.3 Mounting the covers	3-8
<b>4. Assembling the secondary arms</b>	<b>3-9</b>
4.1 Make an assembly	3-9
4.2 Mount the arm assembly on the robot	3-10
<b>5. Mounting the rotational axis on the cardan joint</b>	<b>3-11</b>
<b>6. Calibration</b>	<b>3-12</b>
<b>7. Gripper interface</b>	<b>3-14</b>
7.1 With rotational axis	3-14
7.2 Without rotational axis	3-14



# 1. Unpacking

## 1.1 Unpacking the shipping box

The robot comes in a special shipping box.

The following step must be carried out to remove the cover from the box:

- Unscrew the screws from the cover of the wooden box
- Now remove the cover

## 1.2 Check the damage

First take out the individual components from the package and check that everything is complete according to the following list:

- 1 x rotational axis (in case of models with optional rotational axis)
- 1 x TCP - Tool Center Point (in case of models without rotational axis)
- 6 x secondary arms
- 12 x springs
- 1 x top cover

Check all the components and the robot for transportation damage.

## 1.3 Lifting and transportation

Before the robot is lifted, it must be ensured that it is free from obstructions.

Remove all the screws where the robot is mounted with in the box.

The robot must be lifted and transported by using lifting tackle or a forklift truck. Two lifting straps has to be attached into two eyebolts that are screwed into the baseplate. The lifting straps has to be long enough and must be routed in such a way that the robot is not damaged.



### WARNING

- THE ROBOT MAY TILT DURING TRANSPORTATION.
- ADDITIONAL SAFEGUARDING MEASURE MUST BE TAKEN.
- WEAR SUITABLE PROTECTIVE CLOTHING IF NECESSARY.
- WHEN USING A FORKLIFT TRUCK, DRIVE EXTREMELY SLOWLY AND CAREFULLY.

## 2. Mounting the robot

The mounting surface for the robot must be machined and of an appropriate quality. It's also possible to use a levelling element to align the robot.

Three M16 bolts are needed to mounting the robot to the frame, exact bolt length depends on frame layout. The tightening torque of a M16 6.8 bolt is 140Nm.

The below figure shows the mounting pattern from the robot.

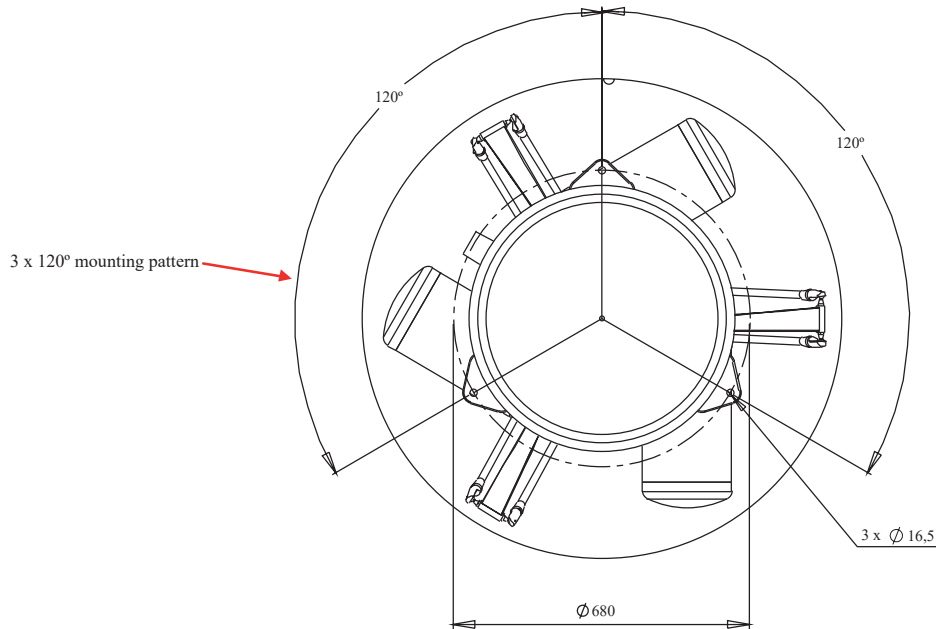

### NOTE

It is advisable to put one motor of the robot in line with the direction of the transport belt to make programming easier.

# 3. Mounting the motors, cabling and gearbox housing

## 3.1 Mounting the motors

When your robot is delivered without motors, you have to mount them by yourself.

Before mounting the servo motors you have to be sure that the clamping hub screw is in the right position. Please see also the below picture.

- Unscrew the blind stop
- Be sure that the head from the clamping hub screw is in line with the hole

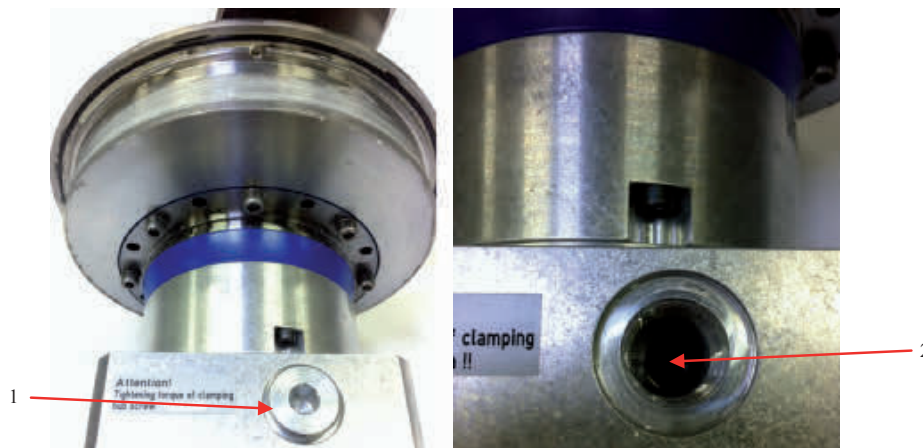

No.	Description
1	Blind stop
2	Clamping hub screw

Now that the clamping hub screw is in the right position, you can install the motor.

Please be sure that the connectors from the motor are correctly positioned.

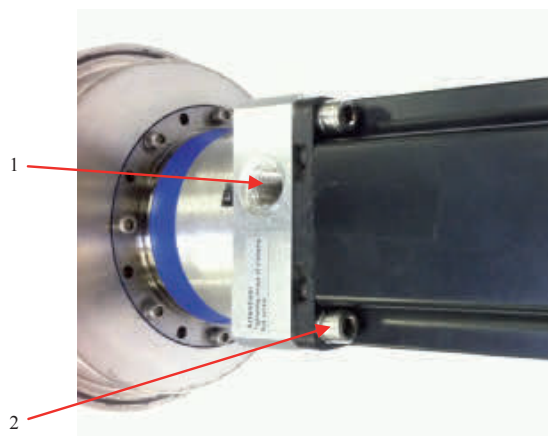

No.	Description
1	Blind stop hole
2	4 x Allen bolt with washer

- Put a drop of Loctite 243 on the 4 Allen bolts
- Now mount the 4 Allen bolts with washers
- Tighten the clamping hub screw with the specified torque
- Mount the blind stop

### 3.2 Mounting the gearbox housing into the body and connecting the cables

First of all we have to feed the servo cables from the electrical cabinet through the cable feed through the pipe in the body (see below picture). Please don't forget to put a hose around the cables to keep water outside the body.

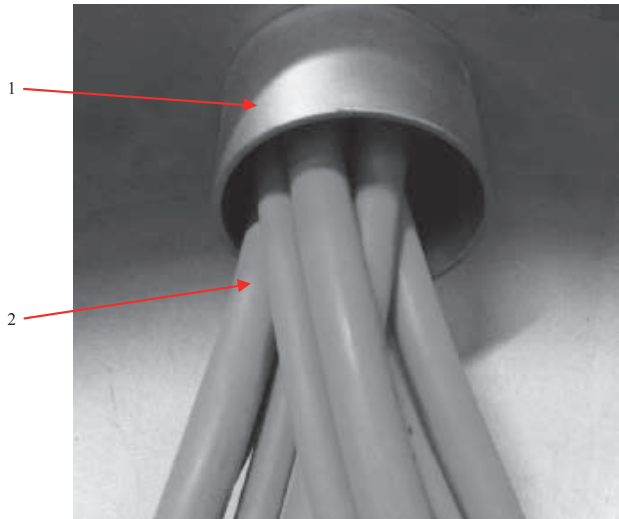

No.	Description
1	Cable feed through pipe
2	Servo cables

The body is executed with 3 compartments. Every compartment has his own number, starting from 1 till 3. The gearbox housing and the nut are also numbered. Please mount all the parts with the same numbers, that means: Compartment 1 with gearbox housing 1 and nut 1.



We will start with assembling of compartment 1:

- Put the plastic ring in the chamber
- Put the nut with number 1 in the chamber

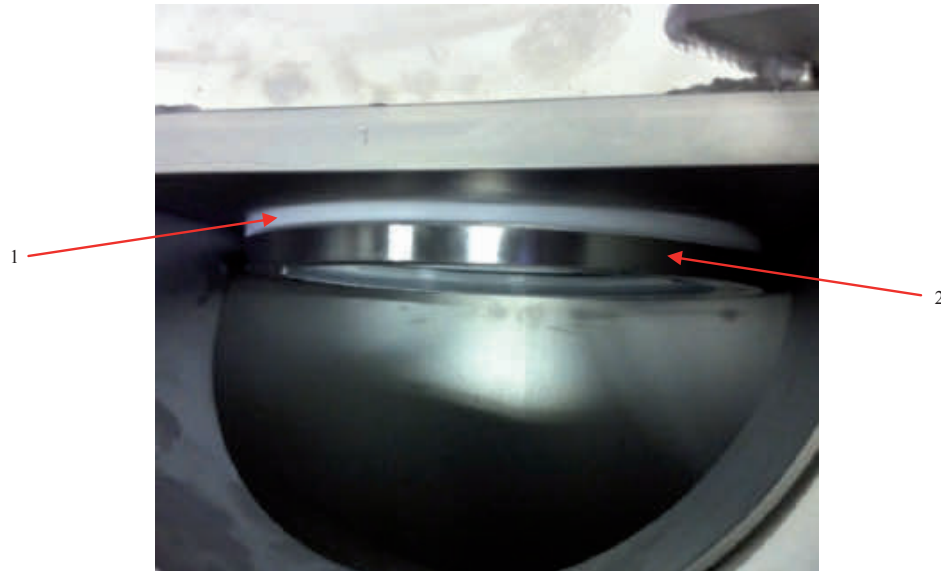

No.	Description
1	Plastic ring
2	Nut

Now feed the servo cables for motor 1 through the hole from the nut, plastic ring and housing.

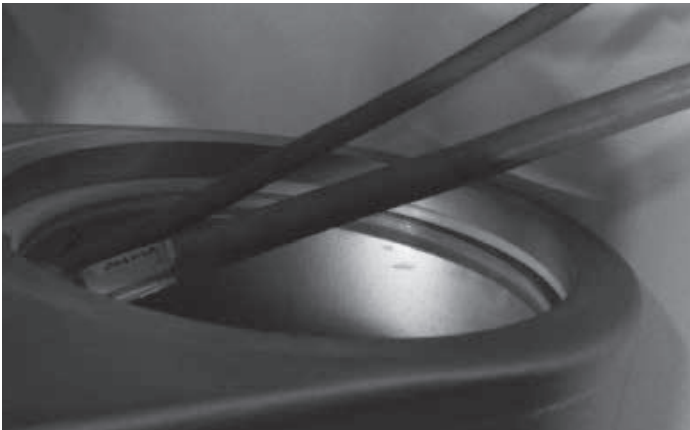

Now attach the cables to the motor.

Now the servo cables are attached, we have to mount the gearbox housing into the body. Please be sure that the rubber O-ring (see below picture) is properly installed into the groove.

As you can see below, there is a dowel pin welded in the ring from the body. The gearbox housing has a cutout for this pin. These have to be mounted into each other.

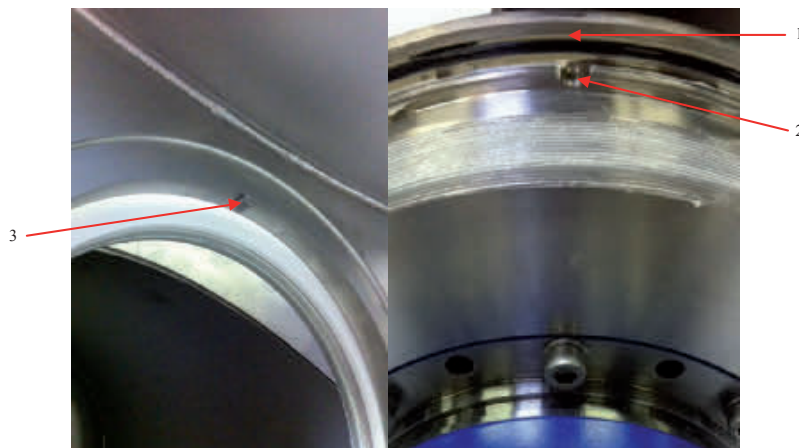

No.	Description
1	O-ring
2	Cutout
3	Dowel pin

Now you have to put the plastic ring on the flange and mount the nut on the screw-thread (see below picture). First try to fasten the nut as far as you can with your hand.

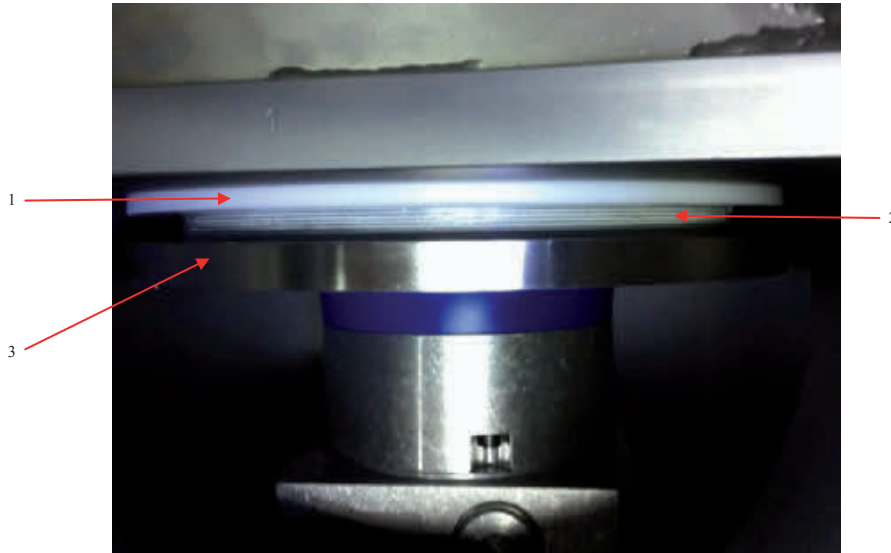

No.	Description
1	Plastic ring
2	Screw-thread
3	Nut

When you can't tighten the nut with your hand anymore, you have to use the special tool which is delivered with your robot (see below picture).

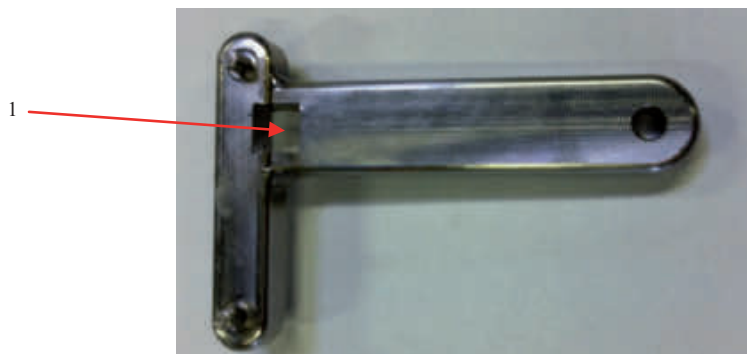

No.	Description
1	Hole for torque wrench 1/2 inch

When the nut is tightened with your hand you have to tighten it with an torque wrench and the special tool as shown below (see next picture). The tightening torque is : 180 Nm.

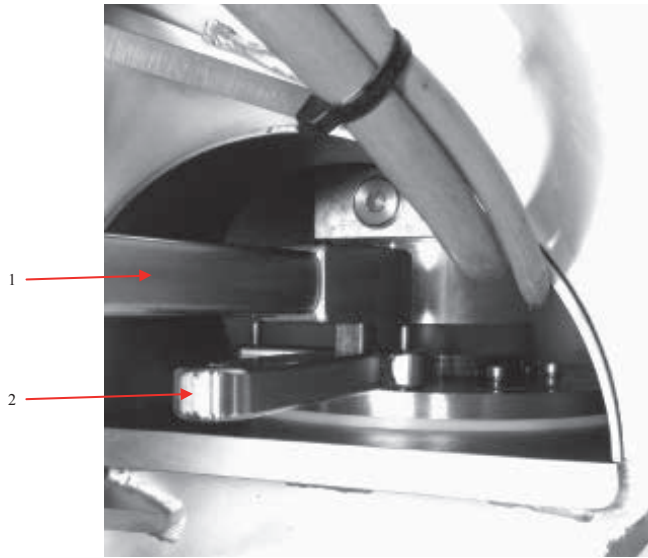

No.	Description
1	Torque wrench
2	Special tool

Repeat these actions also for the other 2 compartments.

Now your motors and gearbox housings are mounted.

### 3.3 Mounting the covers

For mounting the cover you first have to adjust the mounting bracket.

- Mount the bracket on the 2 thread-ends (see below picture)

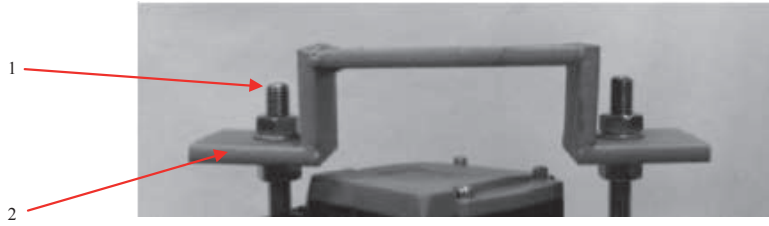

No.	Description
1	Thread-end
2	Bracket

- Adjust the height from the bracket to between 26-29 cm (see below picture)

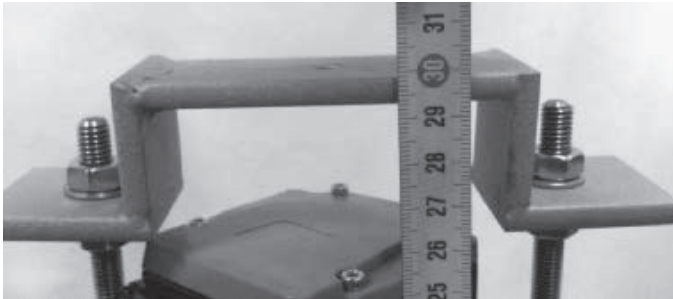

- Now lock the 4 nuts so the bracket is mounted
- Now mount the cover on the robot with the special bolt, please be sure that the edge of the robot body is totally covered

## 4. Assembling the secondary arms

### 4.1 Make an assembly

Before mounting the secondary arms on the robot, we have to pre-assemble them as shown on the below figure, so that we get an arm assembly.

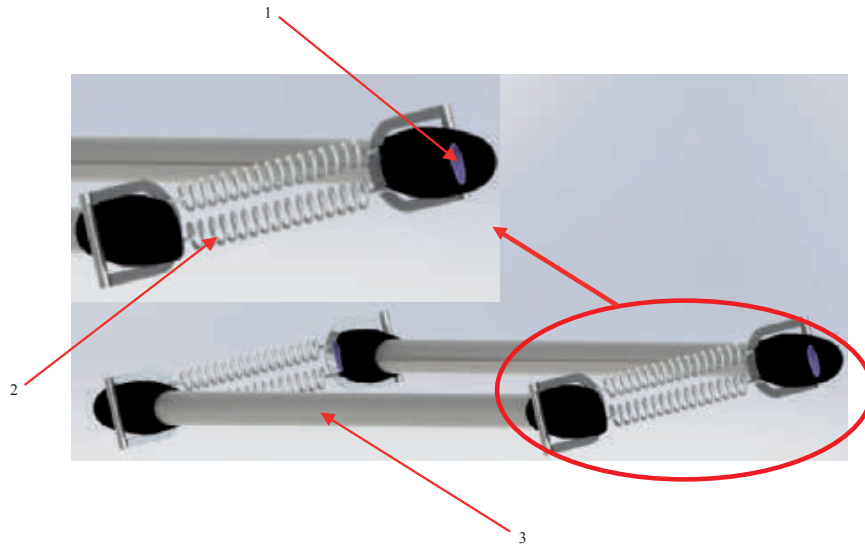

No.	Description
1	Sanitary cup holder incl. ball bearing cup
2	Spring package
3	Secondary arm

Repeat this action for the other 2 arm sets.



#### WARNING

- INCORRECT MOUNTED SPRINGS CAN JUMP AWAY.
- WEAR SUITABLE PROTECTIVE CLOTHING AND SAFETY GLASSES.
- NEVER PULL THE SPRINGS FURTHER APART THAN NECESSARY WHEN MOUNTING THE ARM ASSEMBLY ON THE PRIMARY ARM OR TCP BALL JOINTS.
- REPLACE SPRINGS AFTER OVERSTRETCHING.

## 4.2 Mount the arm assembly on the robot

For mounting, pull a secondary arm with his cup holder over the ball joint of the primary arm. Now pull the arms apart against the force of the spring in order to pull the second arm over the second ball joint of the primary arm. Then repeat this action for the TCP (see below picture).

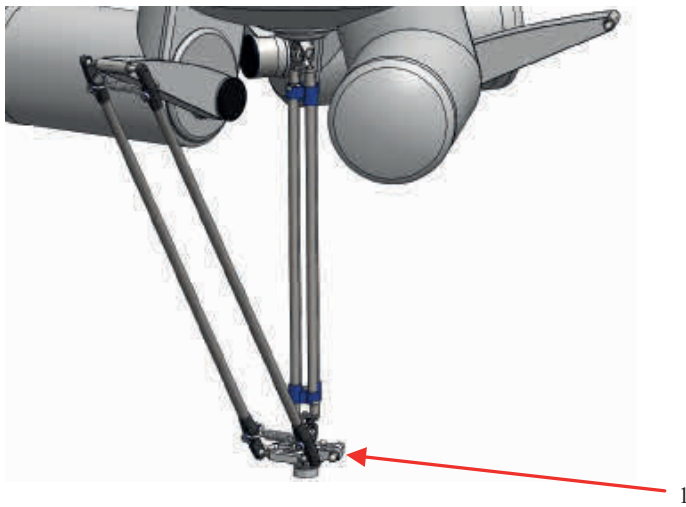

No.	Description
1	TCP - Tool Center Point

Repeat this action for the other 2 secondary arm assembly's.  
Now your robot mechanic is completely installed.

## 5. Mounting the rotational axis on the cardan joint

This section is applicable only to the models with rotational axis.

Please perform the following steps first.

- Extend the rotational axis to its entire length, then retract the same and check whether it is easy to operate or whether some resistance occurs



### NOTE

A light irregular resistance is normal and caused by the manufacturing tolerances of the tubes. The axis is run in during the first 150 hours of operation. In case of problems, please check the axis for damage or contact your OMRON representative.

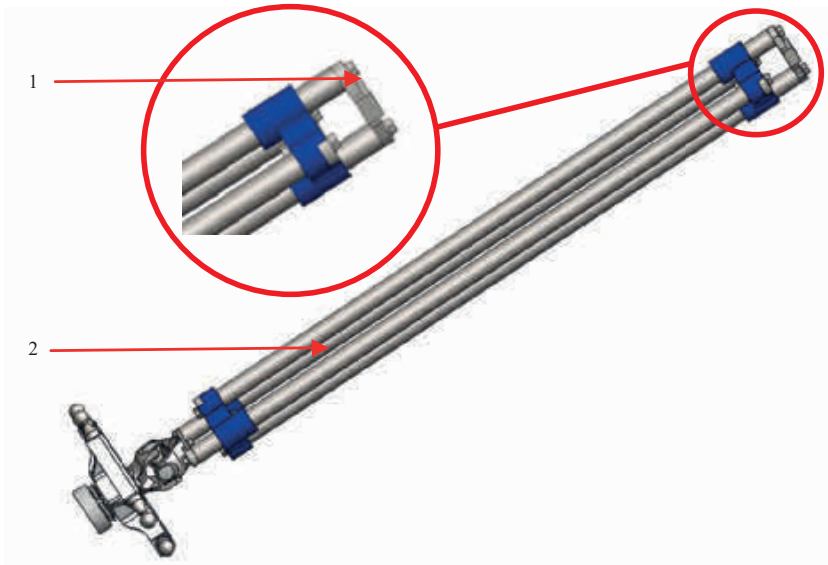

No.	Description
1	Hole for M5 mounting bolt
2	Rotational axis

Assembling to the cardan joint:

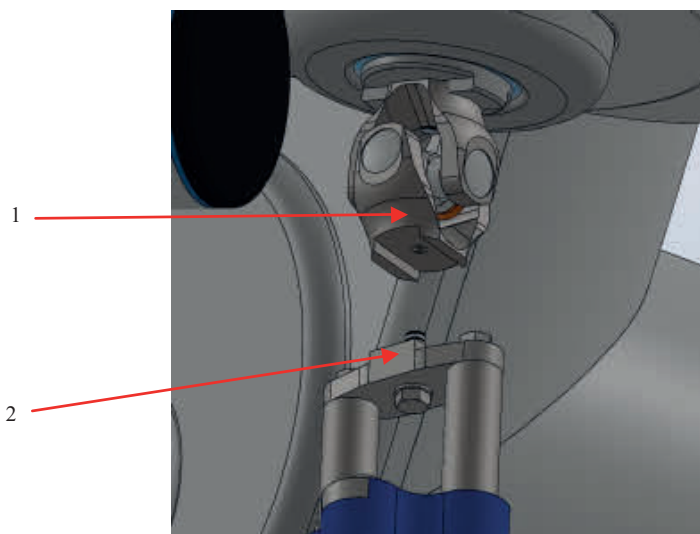

No.	Description
1	Cardan joint
2	Top connector rotational axis

- Put a drop of Loctite 243 on the supplied M5 bolt with washer
- Now attach the top connector to the cardan joint
- Tighten the M5 hexagon bolt with 9Nm

The rotational axis is now mounted.

## 6. Calibration

No every robot that is delivered is calibrated.

If you want to calibrate the robot by yourself, a calibration tool is available (shown in the below picture). The calibration tool can be ordered as CR\_AS-2279 for CR\_UGD4\_XL\_HD and CR\_UGD4\_HD robots, or CR\_AS-3062 for CR\_UGD4\_XS\_HD robot.

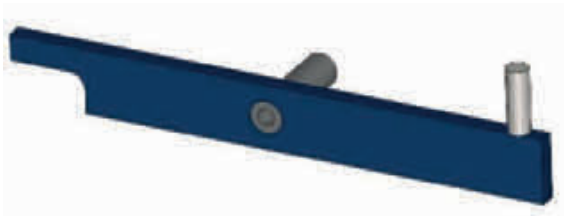

No.	Description
1	Calibration tool

The following steps must be carried out to put the three upper arms from the robot in the zero position. Please, see the below pictures:

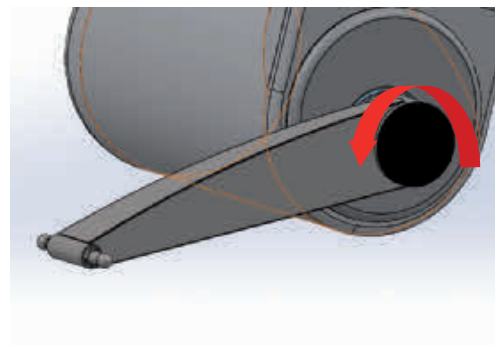
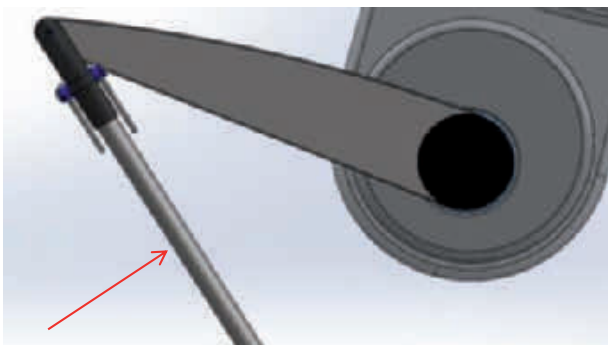

- Remove all the 6 secondary arms
- Remove the 3 plastic covers from the primary arms

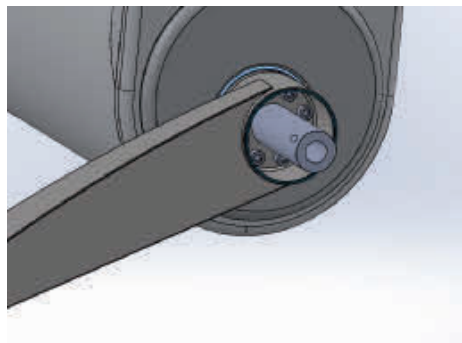
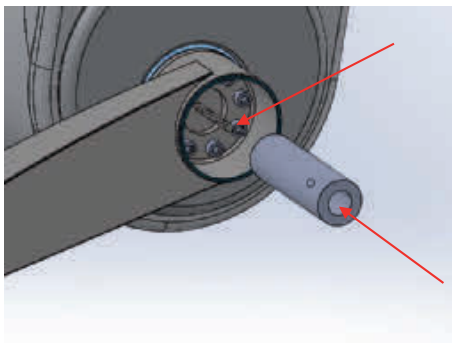

- Mount the temporary axis on the thread from the plastic cover

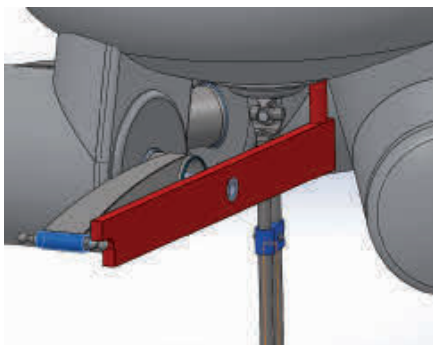

- Now place the calibration tool on the temporary axis
- Release the motor brake from the selected motor and push the upper arm with his ball joint against the calibration tool as shown in the above picture
- Now fix the motor brake from the selected motor
- Repeat the calibration steps for the other two primary arms
- Remove the tool



#### WARNING

- CALIBRATING THE ROBOT MUST BE CARRIED OUT BY QUALIFIED PROGRAMMING PERSONNEL ONLY, AS THIS REQUIRES AN EXCELLENT LEVEL OF KNOWLEDGE OF THE CONTROL SYSTEM.
- WHEN CARRYING OUT THE HOMING YOURSELF, THIS MUST BE CARRIED OUT EXACTLY IN THE WAY AND THE ORDER THAT THEY ARE DESCRIBED.

- Now all the primary arms are in zero position from the kinematic model
- Now put the encoder values from the servo motors in 0°
- Check that the angle indicated for the three motors is 0° ( $\pm 0.1^\circ$ )
- Your robot is now calibrated

## 7. Gripper interface

### 7.1 With rotational axis

The below picture shows the gripper connection sizes for the models with rotational axis according to ISO 9409-1-A31,5.

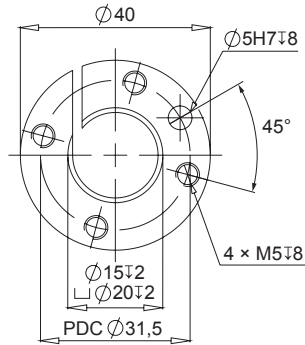

### 7.2 Without rotational axis

The below picture shows the gripper connection sizes for the models without rotational axis.

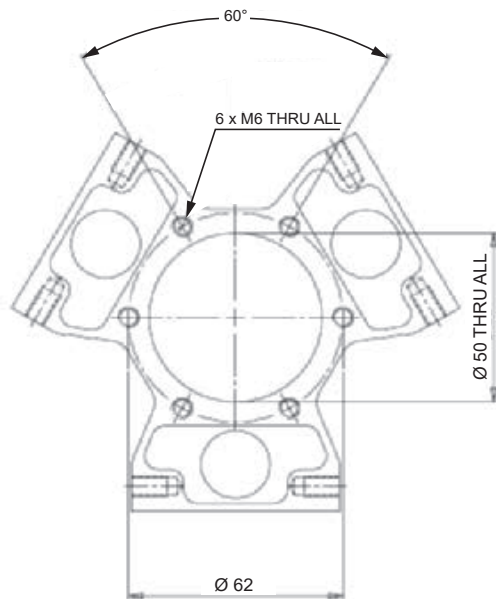

The design of the gripper that is mounted under the robot have great influence on the performance of the robot. Both the weight of the gripper and the distance of the center of gravity of the gripper to the TCP base point have negative influence on the final performance of the robot.

If you need to install cabling for the gripper, please follow the following steps:

- Mount the cables on the baseplate or frame, near the turning point from the primary arm on the gearbox
- Mount the cables on the primary arm, with ty-raps or clamping parts
- Keep a big loop at the hinge point from the primary and secondary arm
- Mount the cables on the secondary arm, with ty-raps or clamping parts
- Keep a big loop from the lowest mounting point at the secondary arm till the connection on the gripper

# Chapter 4 Maintenance

## Contents

<b>1. Periodic maintenance</b>	<b>4-1</b>
1.1 Springs	4-1
1.2 Ball bearing cups	4-2
1.3 Rotational axis	4-2
<b>2. Cleaning the robot</b>	<b>4-4</b>
<b>3. Spare parts</b>	<b>4-4</b>



# 1. Periodic maintenance

Before working on the robot, please be ensured that the machine where the robot is built in, is totally switched off.



## DANGER

- SWITCH OFF THE MACHINE ( SYSTEM ) WHERE THE ROBOT IS BUILT IN (E.G. WITH A PADLOCK) TO PREVENT IT FROM BEING SWITCHED ON AGAIN.
- LABEL THE MACHINE (SYSTEM) WITH A SIGN INDICATION THAT WORK IS IN PROGRESS. THIS SIGN MUST REMAIN IN PLACE, EVEN DURING TEMPORARY INTERRUPTIONS TO THE WORK.
- THE EMERGENCY STOP FROM THE MACHINE (SYSTEM) MUST REMAIN ACTIVE. IF SAFETY FUNCTIONS OR SAFEGUARDS ARE DEACTIVATED DURING MAINTENANCE OR REPAIR WORK, THEY MUST BE REACTIVATED IMMEDIATELY AFTER THE WORK IS COMPLETED.

## 1.1 Springs

How to maintain the springs:

- The springs has to be replaced every 3800 working hours or once a year
- When the robot is fall apart, check the springs on damages
- Only use springs delivered by OMRON, otherwise the guarantee will expire
- Replace springs after overstretching
- For spare parts, see **Section 3 Spare parts** in this chapter



## WARNING

- INCORRECT MOUNTED SPRINGS CAN JUMP AWAY.
- WEAR SUITABLE PROTECTIVE CLOTHING AND SAFETY GLASSES.
- NEVER PULL THE SPRINGS FURTHER APART THAN NECESSARY WHEN MOUNTING THE ARM ASSEMBLY ON THE PRIMARY ARM OR TCP BALL JOINTS.

How to disassemble the springs:

- Disassemble the secondary arms from the robot
- Replace the springs
- For re-assembling the secondary arms, see **Section 4 Assembling the secondary arms** in Chapter 3

## 1.2 Ball bearing cups

The ball bearing cups has the same lifetime as the springs. We recommend to exchange these at the same time as the springs.

How to maintain the ball bearing cups:

- The ball bearing cups has to be replaced every 3800 working hours or once a year
- When the ball bearing cups make squeaking noises, take of the secondary arm assembly's and clean the cups with pressed air
- **Do not lubricate the ball bearing cups!**

For instructions to replace the ball bearing cups, see below picture:

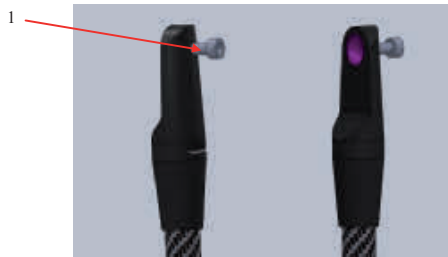

No.	Description
1	M5 bolt

- Screw an M5 bolt in the backside from the cup holder
- Now the ball bearing cup will come out

## 1.3 Rotational axis

The plain bearings on the rotational axis wear with time so that backlash starts to occur on the rotational axis. How fast the plain bearings become worn depends strongly on the following factors:

- The working path
- The payload
- The speed of the robot
- The rotation actions

When do I have to exchange the plain bearings?

- If there is a lot of play on the rotational axis
- Every 3000 working hours or once a year

For instructions to replace the plain bearings, see below picture:

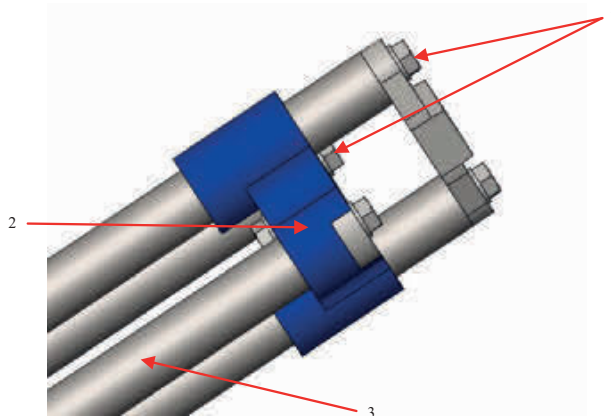

No.	Description
1	4 x M5 bolt with washer
2	Bearing block
3	Rotation tube

- Unscrew the 4 x M5 bolt with washer from the cardan connector and the bearing block
- Remove the cardan connector and the bearing block

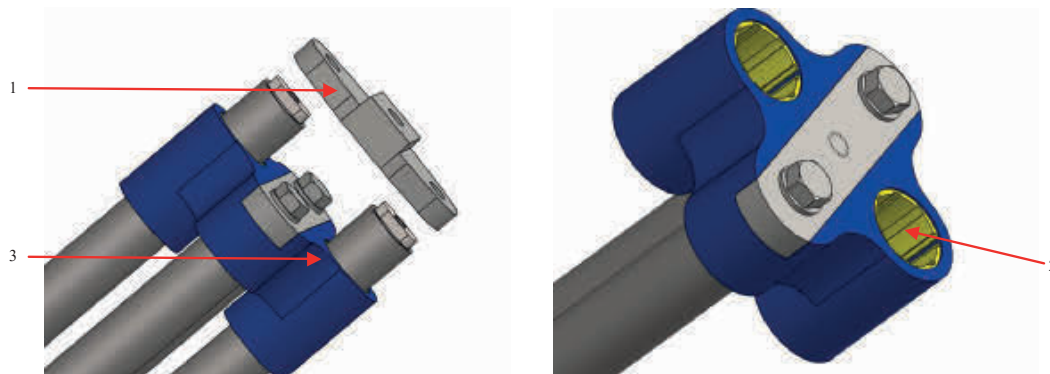

No.	Description
1	Cardan connector
2	Plain bearing
3	Bearing block

- Now you can exchange the 2 plain bearings
- For the other bearing block, you can repeat these steps
- To re-assemble the parts you can follow these steps in reverse direction
- Tighten the M5 bolts with 7 Nm and put a drip of Loctite 243 on the bolts



#### WARNING

- PLAIN BEARINGS HAS TO BE MOUNTED VERY CAREFULLY.
- WRONG MOUNTED PLAIN BEARINGS MAY DAMAGE.
- EXTEND THE ROTATIONAL AXIS TO ITS ENTIRE LENGTH, THEN RETRACT THE SAME AND CHECK WHETHER IT IS EASY TO OPERATE OR WHETHER SOME RESISTANCE OCCURS.

















## 2. Cleaning the robot





Clean the robot by washing with soft cloth or sponge. Use soap or mild detergent and warm water followed by clear water rinse.

For oil and grease stains use alcohol with soft cloth.













## 3. Spare parts

### Common spare parts (models with/without rotational axis)

Robot part	Description	Quantity per robot	OMRON Part No.		
			CR_UGD4_XL_  _HD	CR_UGD4_  _HD	CR_UGD4_XS_  _HD
Primary arm	1 x primary arm	3	CR_AS-2906 	CR_AS-2905 	CR_AS-2904 
	1 x primary arm seal	3	CR_CP-1068 		
	1 x seal ring	3	CR_PT-05393 		
	1 x primary arm cap	3	CR_PT-06774 		
Secondary arm	1 x secondary arm	6	CR_AS-2189 	CR_AS-2168 	CR_AS-2468 
	1 x secondary arm spring	6	CR_AS-2291 		
	1 x ball joint cup	12	CR_PT-05291 		
	1 x spring roll	24	CR_PT-05158 		
Primary arm & TCP	1 x ball joint	12	CR_AS-2907 		
Gearbox for primary arm	1 x gearbox	3	CR_GEARP-39 		
Calibration tool	1 x calibration tool	1	CR_AS-2279 		CR_AS-3062 

Robot part	Description	Quantity per robot	OMRON Part No.		
			CR_UGD4_XL_[]_HD	CR_UGD4_[]_HD	CR_UGD4_XS_[]_HD
Others	1 x 3 m cable hose	1	CR_CP-1130-03M 		
	1 x 5 m cable hose		CR_CP-1130-05M 		
	1 x 10 m cable hose		CR_CP-1130-10M 		
	1 x 60-65 mm hose clamp	2	CR_CP-1129 		
	1 x cable entry plug	1	CR_AS-3130 		

## Spare parts for models with rotational axis

Robot part	Description	Quantity per robot	OMRON Part No.		
			CR_UGD4_XL_R_HD	CR_UGD4_R_HD	CR_UGD4_XS_R_HD
Rotational axis	1 x cardan joint	2	CR_AS-4282 		
	1 x spline part rotational axis	1	CR_AS-4238 	CR_AS-4086 	CR_AS-4085 
	1 x complete rotational axis	1	CR_AS-4240 	CR_AS-4088 	CR_AS-4090 
	1 x plain bearing	4	CR_CP-1013 		
	1 x bearing 2	2	CR_CP-1026 		
	1 x seal rotation	2	CR_CP-1071 		
Gearbox for rotational axis	1 x gearbox	1	CR_GEARP-14 		
TCP - Tool Center Point	1 x gripper flange	1	CR_AS-2976 		
	1 x TCP	1	CR_AS-2169 		

**Spare parts for models without rotational axis**

Robot part	Description	Quantity per robot	OMRON Part No.		
			CR_UGD4_XL_NR_HD	CR_UGD4_NR_HD	CR_UGD4_XS_NR_HD
TCP - Tool Center Point	1 x TCP	1	CR_AS-2181 		

# Chapter 5 Robot settings

## Contents

1. Kinematics	5-1
2. Workspace	5-2
3. Software limits	5-3



# 1. Kinematics

The kinematics parameters for the CR\_UGD4\_HD robots are shown below. Set these parameters corresponding to the controller settings.



## WARNING

IF THE KINEMATICS PARAMETERS ARE NOT SET PROPERLY, THIS MAY CAUSE THE ROBOT TO MALFUNCTION. SO, BE SURE TO SET THESE PARAMETERS CORRECTLY.

## Kinematics parameters

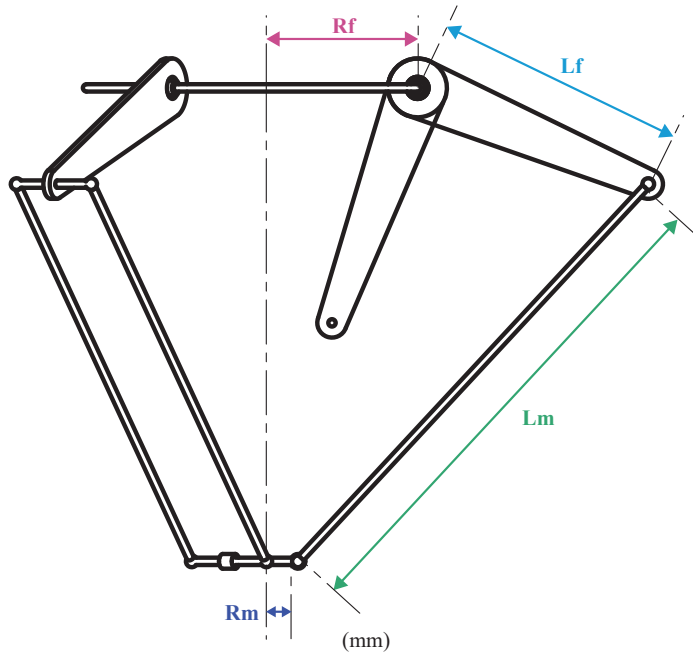

### CR\_UGD4\_XL\_HD

- Rf:** 200 mm Distance (radius) from the center of the fixed frame to the motor of the axis
- Rm:** 50 mm Distance (radius) from the center of the moving frame to the connection point of Link 2
- Lf:** 420 mm Length of Link 1
- Lm:** 950 mm Length of Link 2

### CR\_UGD4\_HD

- Rf:** 200 mm Distance (radius) from the center of the fixed frame to the motor of the axis
- Rm:** 50 mm Distance (radius) from the center of the moving frame to the connection point of Link 2
- Lf:** 320 mm Length of Link 1
- Lm:** 850 mm Length of Link 2

### CR\_UGD4\_XS\_HD

- Rf:** 200 mm Distance (radius) from the center of the fixed frame to the motor of the axis
- Rm:** 50 mm Distance (radius) from the center of the moving frame to the connection point of Link 2
- Lf:** 220 mm Length of Link 1
- Lm:** 600 mm Length of Link 2

## 2. Workspace

The workspace parameters for the CR\_UGD4\_HD robots are shown below. Set these parameters corresponding to the controller settings.



### WARNING

IF THE WORKSPACE PARAMETERS ARE NOT SET PROPERLY, THIS MAY CAUSE THE ROBOT TO MALFUNCTION. SO, BE SURE TO SET THESE PARAMETERS CORRECTLY.

### Workspace parameters

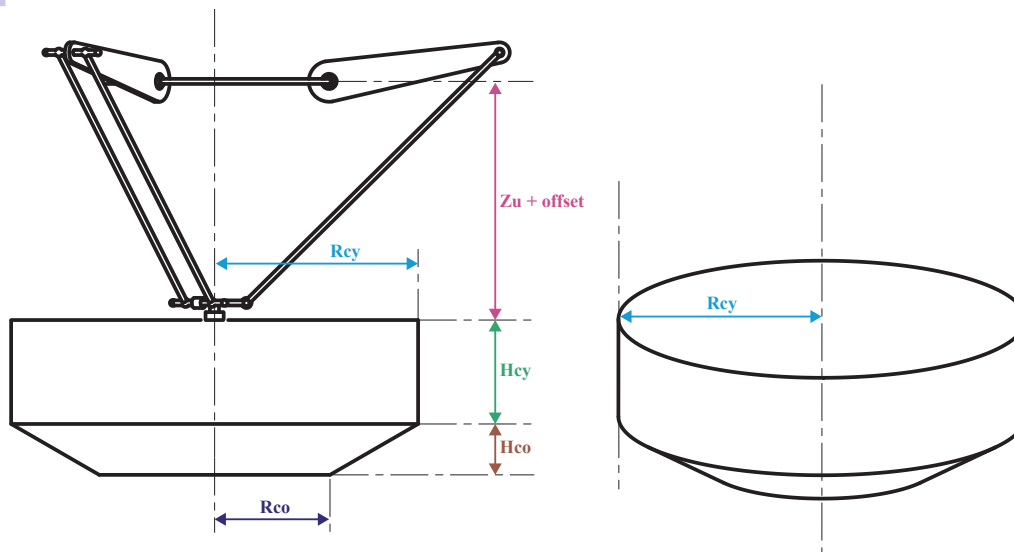

#### CR\_UGD4\_XL\_HD

**Zu + offset:** -748,5 mm with rotational axis / -723,5 mm without rotational axis

**Rcy:** 650 mm Radius of the cylinder

**Hcy:** 250 mm Height of the cylinder

**Rco:** 435 mm Radius of the frustum cone of underside

**Hco:** 150 mm Height of the frustum cone

#### CR\_UGD4\_HD

**Zu + offset:** -648,5 mm with rotational axis / -623,5 mm without rotational axis Distance from the Z-axis origin position to the tool flange

**Rcy:** 550 mm Radius of the cylinder

**Hcy:** 250 mm Height of the cylinder

**Rco:** 335 mm Radius of the frustum cone of underside

**Hco:** 150 mm Height of the frustum cone

#### CR\_UGD4\_XS\_HD

**Zu + offset:** -472,5 mm with rotational axis / -447,5 mm without rotational axis Distance from the Z-axis origin position to the tool flange

**Rcy:** 325 mm Radius of the cylinder

**Hcy:** 200 mm Height of the cylinder

**Rco:** 203.75 mm Radius of the frustum cone of underside

**Hco:** 70 mm Height of the frustum cone

### 3. Software limits

The software limits for the CR\_UGD4\_HD robots are shown below.



**WARNING**

IF THE  $\alpha$ -,  $\beta$ - OR  $\gamma$ - AXIS SOFT LIMIT IS SET INCORRECTLY, THE ARM MAY COLLIDE WITH THE ROBOT BASE OR BASE PREPARED BY THE USER, CAUSING BREAKAGE. SO, BE SURE TO SET THE SOFT LIMITS CORRECTLY.

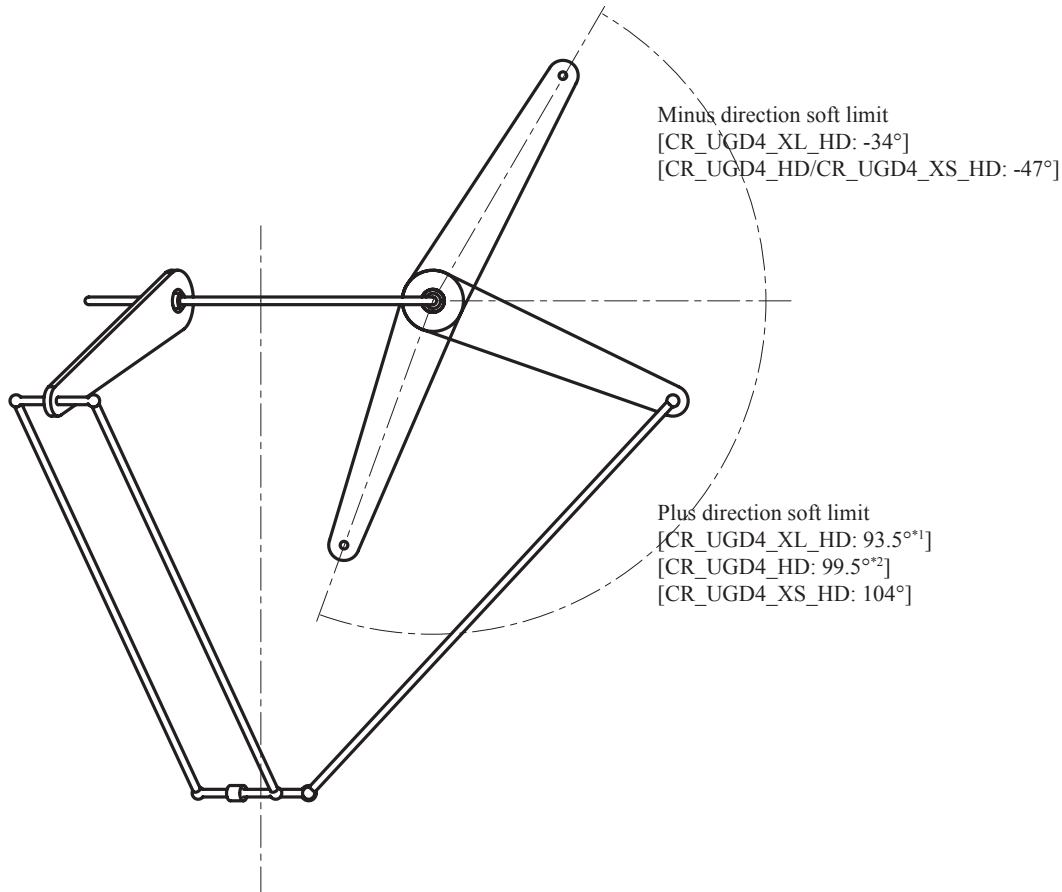

\*1. For the CR\_UGD4\_XL\_HD robots ordered before September 2023, the Positive software limit is 93°.

\*2. For the CR\_UGD4\_HD robots ordered before September 2023, the Positive software limit is 99°.



# Chapter 6 Specifications

## Contents

<b>1. Basic specifications</b>	<b>6-1</b>
1.1 Cycle time	6-2
<b>2. External view and dimensions</b>	<b>6-3</b>
2.1 CR_UGD4_XL_HD	6-3
2.2 CR_UGD4_HD	6-4
2.3 CR_UGD4_XS_HD	6-5
<b>3. Design specifications</b>	<b>6-6</b>
3.1 Occupation area of robot	6-6
3.2 Software design	6-7
3.2.1 Dimensions and limits	6-8



# 1. Basic specifications

Robot model			CR_UDG4_XL_R_HD	CR_UDG4_XL_NR_HD	CR_UDG4_R_HD	CR_UDG4_NR_HD	CR_UDG4_XS_R_HD	CR_UDG4_XS_NR_HD
Working volume	X, Y axis	Stroke	Ø1300mm		Ø1100mm		Ø650mm	
	Z axis	Stroke	250mm (max. Ø1300mm)/ 400mm (center Ø870mm)		250mm (max. Ø1100mm)/ 400mm (center Ø670mm)		200mm (max. Ø650mm)/ 270mm (center Ø407.5mm)	
	θ axis	Rotation range	±180° (default setting, it can be changed)		±180° (default setting, it can be changed)		±180° (default setting, it can be changed)	
Servo motor	Arm 1, 2, 3		1000W					
	Rotational axis 4		750W		750W		750W	
Repeatability *1	X, Y, Z axis		±0.2mm					
	θ axis		±0.3°		±0.3°		±0.3°	
Maximum through-put *2			120 CPM*3		150 CPM*3		170 CPM*3	
Maximum payload			2kg					
Gearbox ratio	X, Y, Z axis		1:31					
	θ axis		1:10		1:10		1:10	
θ axis torque limitation			7Nm		7Nm		7Nm	
Travel limit			Soft limit					
Noise level			< 68 dB (A)					
Ambient temperature			5°C to 45°C					
Relative humidity			Max. 90%					
Protection class			IP69K					
Weight			100kg					

\*1: This is the value at a constant ambient temperature.

\*2: With 0.1kg payload. When reciprocating 305mm in horizontal and 25mm in vertical directions.

\*3: CPM: Cycle per minutes. Check the note 2 for the cycle definition.

The encoder, power and brake cables are included with the Delta robot. The last numbers of the Delta robot model code indicate the length of the cables:

Model	Cable length
CR_UDG4_xx_xx_HD3	3 m
CR_UDG4_xx_xx_HD5	5 m
CR_UDG4_xx_xx_HD10	10 m
CR_UDG4_xx_xx_HD15	15 m
CR_UDG4_xx_xx_HD20	20 m

## 1.1 Cycle time

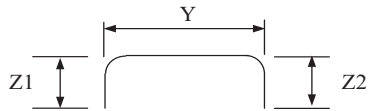

P&P path	Payload	CR_UGD4_XL_HD cycle time	CR_UGD4_HD cycle time	CR_UGD4_XS_HD cycle time
25 x 305 x 25 mm (Z1 x Y x Z2)	0.1 kg	0.48 s	0.41 s	0.37 s
	0.5 kg	0.56 s	0.52 s	0.44 s
	1 kg	0.64 s	0.61 s	0.56 s

## 2. External view and dimensions

### 2.1 CR\_UGD4\_XL\_HD

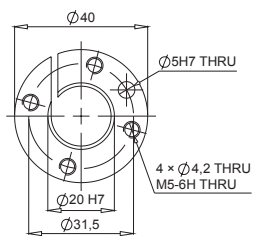
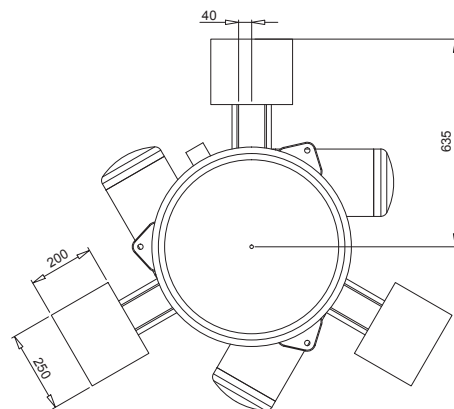
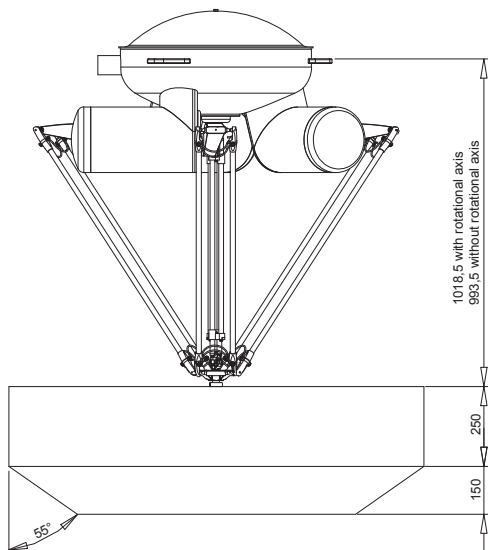
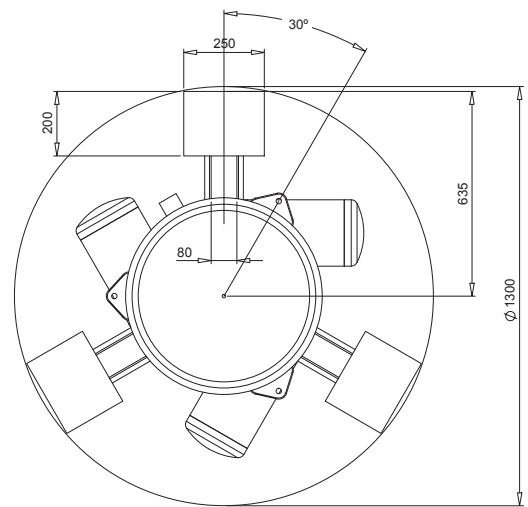
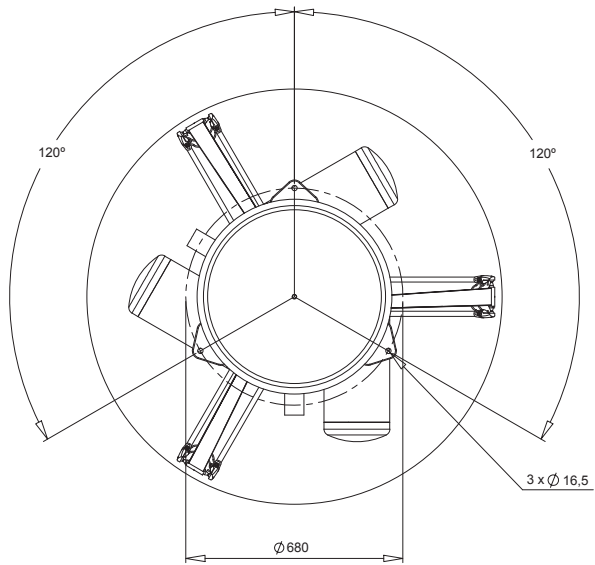

Gripper dimensions

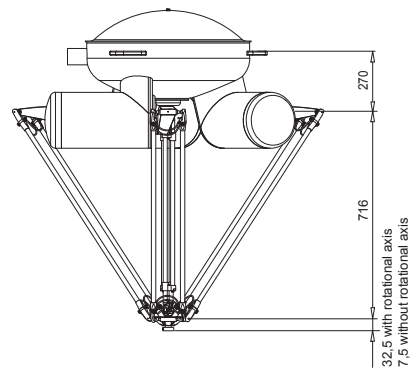

## 2.2 CR\_UGD4\_HD

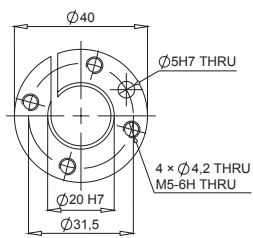
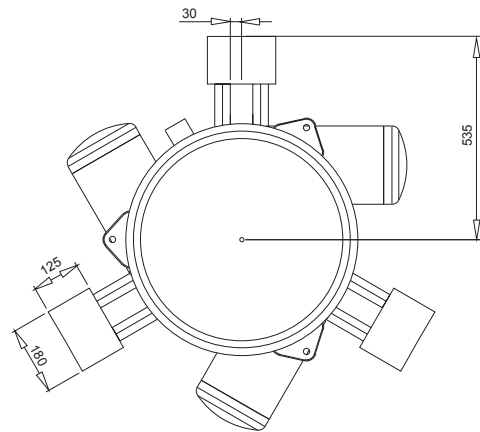
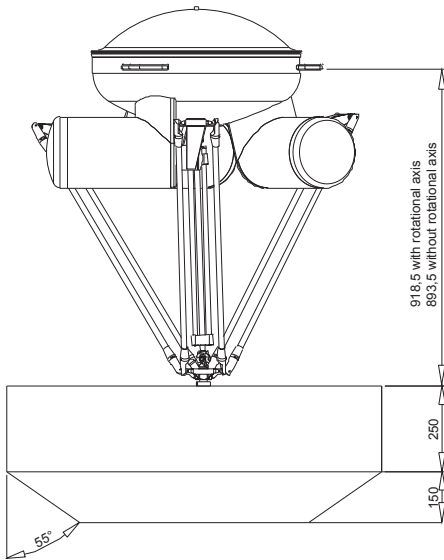
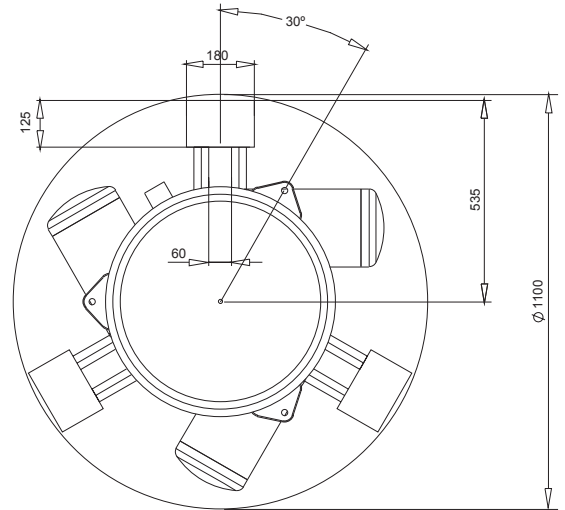
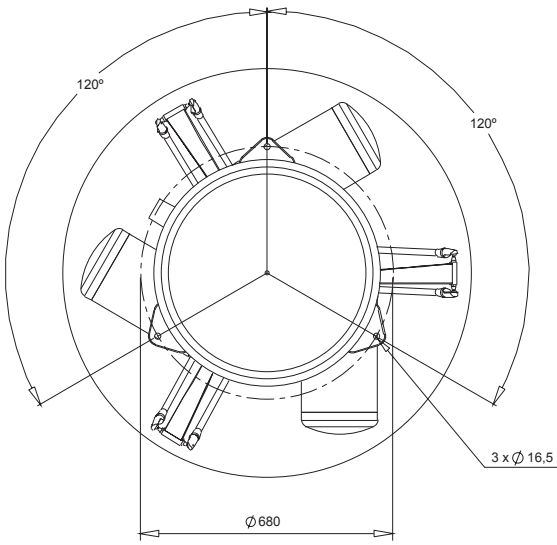

Gripper dimensions

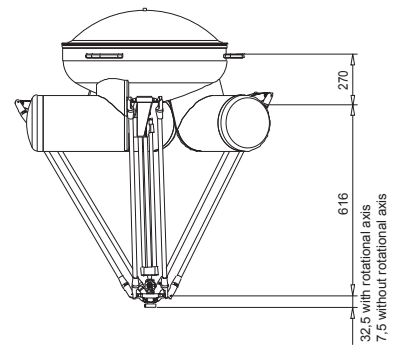

## 2.3 CR\_UGD4\_XS\_HD

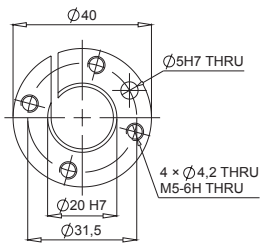
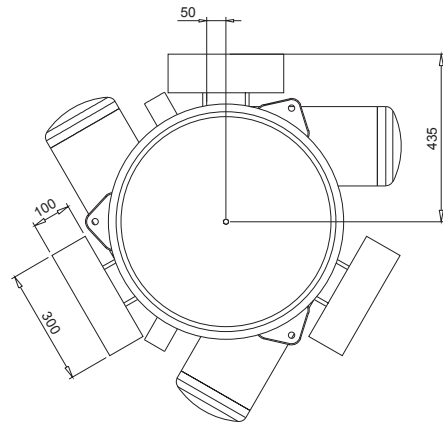
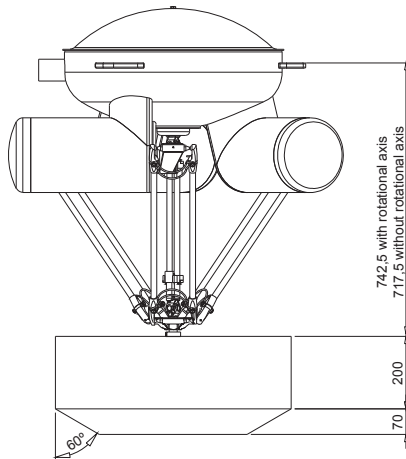
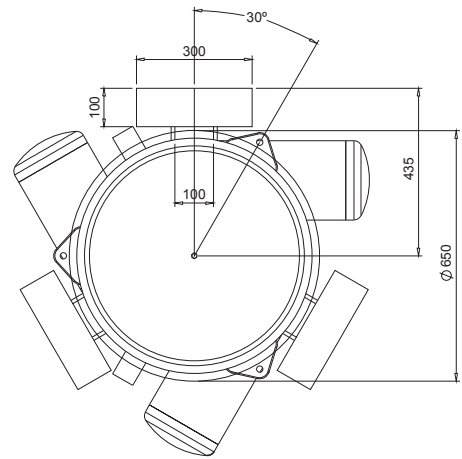
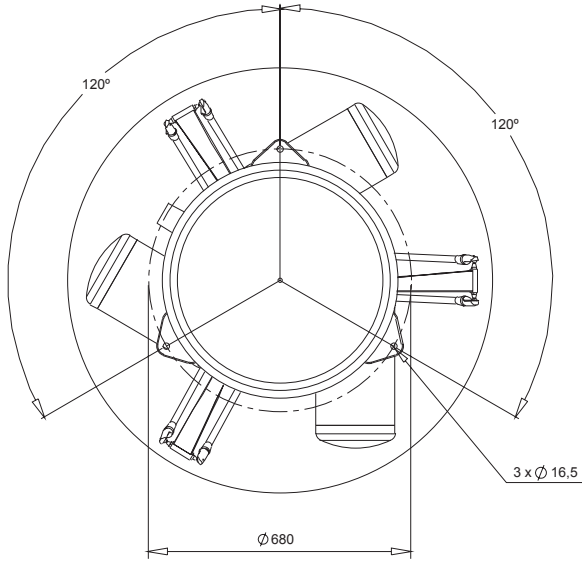

Gripper dimensions

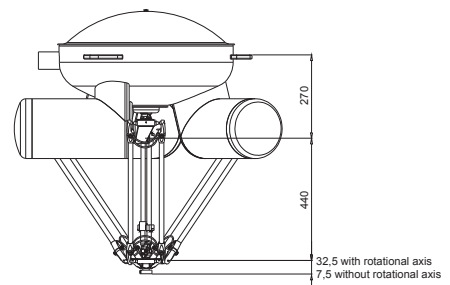

## 3. Design specifications

### 3.1 Occupation area of robot

If the robot is integrated into the machine it must be considered what the reach is of all robot parts to prevent collision with other parts in the machine.

When the TCP moves to its outer positions, the primary and secondary arms can rise above the baseplate, take care that no mechanical obstructions are in the areas indicated in the below figure.

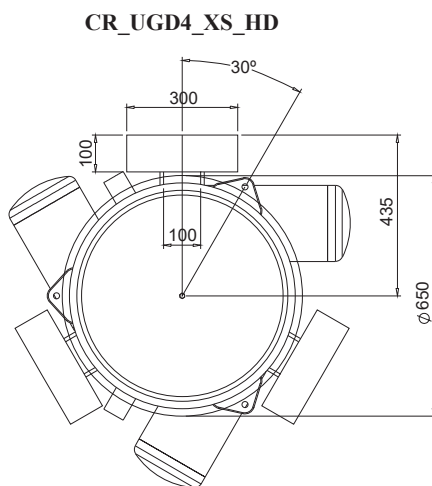
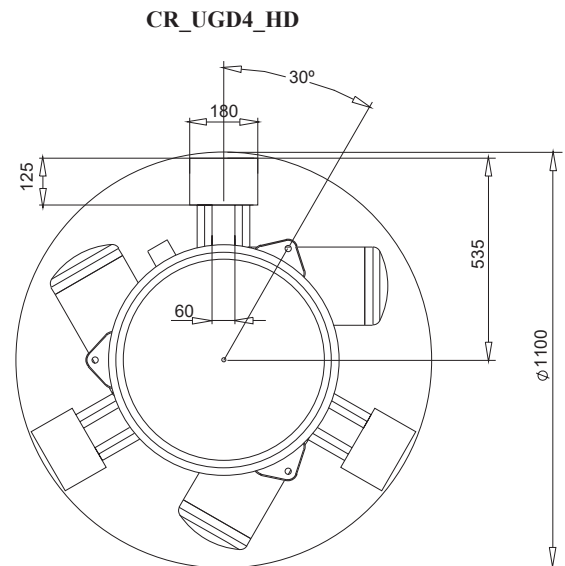
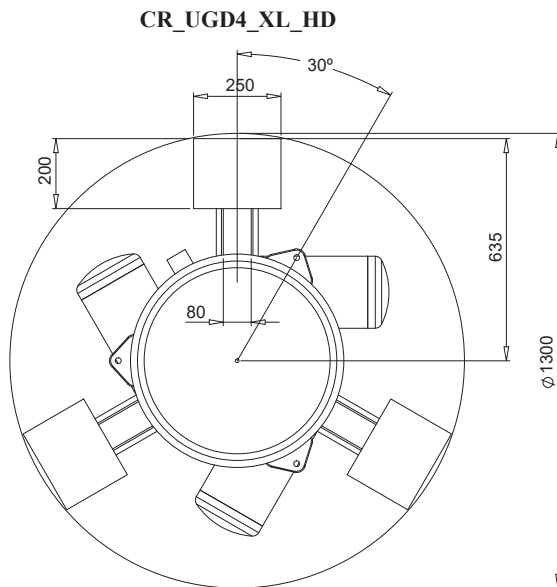

#### WARNING

IF MECHANICAL OBSTRUCTIONS ARE IN THE INDICATED AREA, THE ROBOT OR THE OTHER MACHINE PARTS COULD BE DAMAGED.

## 3.2 Software design

The arm lengths and pitch circles of the rotation points are shown in the below picture.

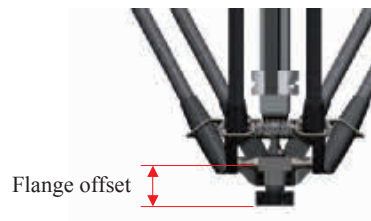
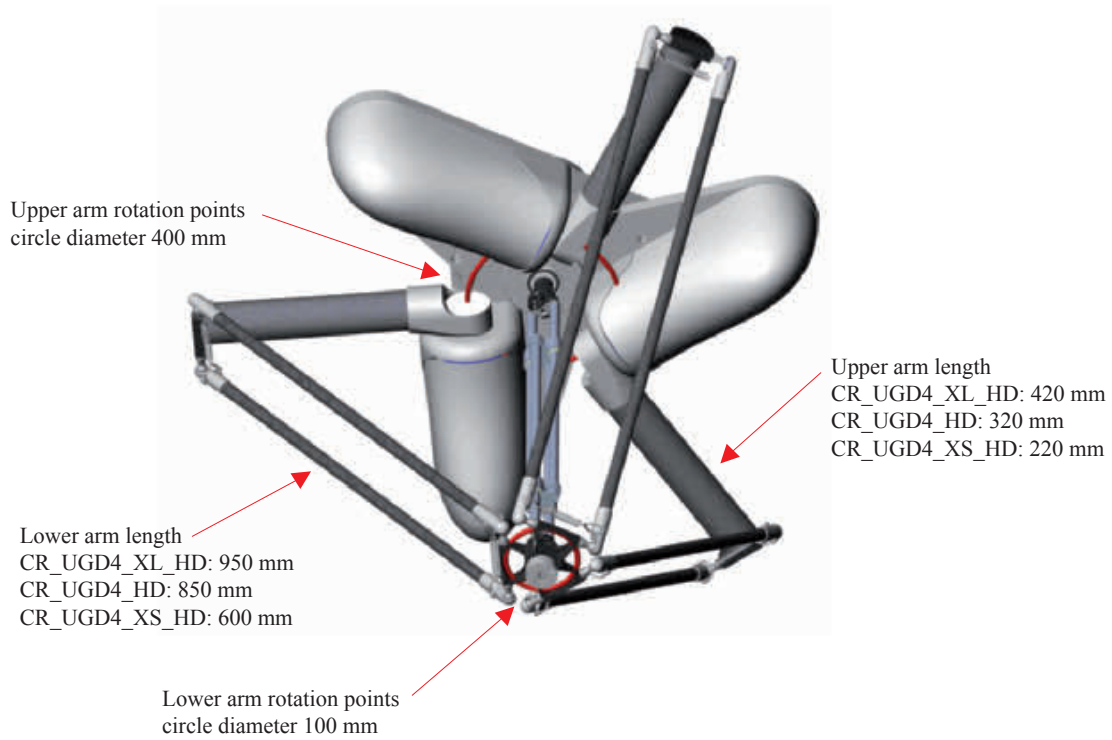

32,5 with rotational axis\*<sup>1</sup>  
7,5 without rotational axis

\*<sup>1</sup>. For the robots with serial number lower than 5903 and with rotational axis, the flange offset is 38,5 mm.

### 3.2.1 Dimensions and limits

Description	CR_UGD4_XL_HD	CR_UGD4_HD	CR_UGD4_XS_HD
Negative software limit	-34°	-47°	
Positive software limit	93,5° <sup>*1</sup>	99,5° <sup>*2</sup>	104°
Tb-z (top baseplate to zero position)	270 mm		
Z-tw (zero position to ball bearings)	716 mm	616 mm	440 mm
Flange offset	32,5 mm with rotational axis <sup>*3</sup> 7,5 mm without rotational axis		

\*1. For the CR\_UGD4\_XL\_HD robots ordered before September 2023, the Positive software limit is 93°.

\*2. For the CR\_UGD4\_HD robots ordered before September 2023, the Positive software limit is 99°.

\*3. For the robots with serial number lower than 5903 and with rotational axis, the flange offset is 38,5 mm.

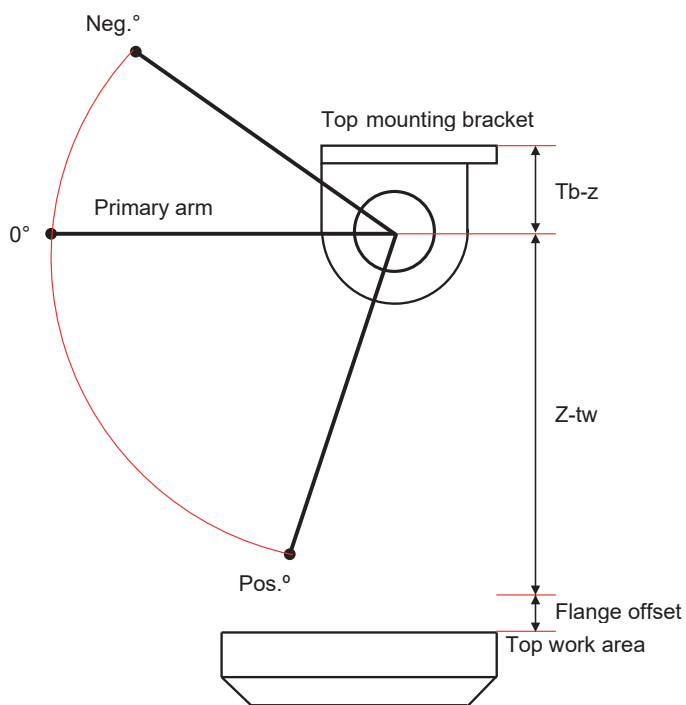

## Revision history

A manual revision code appears as a suffix to the catalog number on the front cover manual.

Cat. No. I199E-EN-04D

↑  
— Revision code

The following table outlines the changes made to the manual during each revision.

Revision code	Date	Description
01	May 2015	Original production
01A	July 2016	Cable hose and hose clamp accessories were added to spare parts section
02	May 2017	New model CR_UGD4_XL_HD was included. Spare parts section was updated. Calibration section was updated. Gripper interface section was updated.
02A	June 2017	Cable entry plug was added to spare parts section
02B	August 2017	ISO gripper flange for robot models with rotational axis was added to spare parts section
02C	September 2017	Basic specifications section was updated
03	December 2017	New model CR_UGD4_XS_HD was included. Spare parts section was updated. Mounting the rotational axis on the cardan joint section was updated. Periodic maintenance for rotational axis section was updated
03A	March 18	Gripper interface dimensions were modified
03B	April 2018	Calibration tool picture was updated
04	June 2018	Spare part references were modified
04A	February 2019	Spare part references were corrected
04B	July 2019	Spare part mistakes were corrected
04C	March 2020	Torque limitation of rotational axis was modified
04D	June 2024	Positive limit of the robot, Flange offset and Spare parts were updated

# OMRON

**Authorized Distributor:**