



Riu Güell, 34
E-17180 Vilablareix – Girona (Spain)
Tel +34 972 244 606
e-Mail: tecnoelectric@teg.es

TEG TOPS

FOR OMRON AUTONOMOUS MOBILE ROBOTS

Brochure

4th June 2021

INDEX

AMR121 – SIDE CONVEYOR.....	2
Technical specifications.....	2
Available options.....	2
Dimensions	3
Pictures.....	4
AMR311 – CART TRANSPORTER	5
Technical specifications.....	5
Available options.....	5
Dimensions	6
Pictures.....	7
AMR321 – CART TRANSPORTER BACKWARD	8
Technical specifications.....	8
Available options.....	8
Dimensions	9
Pictures.....	10
AMR331 – CART TRANSPORTER FORWARD	11
Technical specifications.....	11
Available options.....	11
Dimensions	12
Pictures.....	13
AMR411 – PALLET LIFT HANDLER	14
Technical specifications.....	14
Available options.....	14
Dimensions	15
Pictures.....	17

AMR121 – SIDE CONVEYOR

For Omron LD-60/LD-90

Technical specifications

Side conveyor with light design for increasing maximum payload.

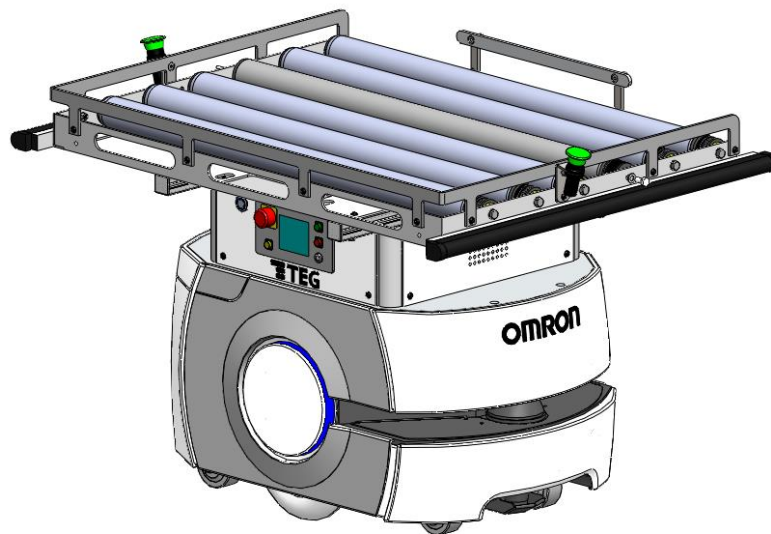

- Light design for payloads up to 60 kg (LD-90)
- Materials: Aluminium, with polycarbonate covers
- Color: White and gray
- Max payload 800 x 600 mm
- Configurable height from 600 mm
- Safety edges included
- Controlled by Sysmac
- Stainless steel and/or green plastic, configurable pushbuttons included
- Double side assembly (left or right)
- 4 payload detectors for 2-boxes transportation

Available options

- Side lasers
- Acuity
- Beacon
- Extra pushbuttons

Dimensions

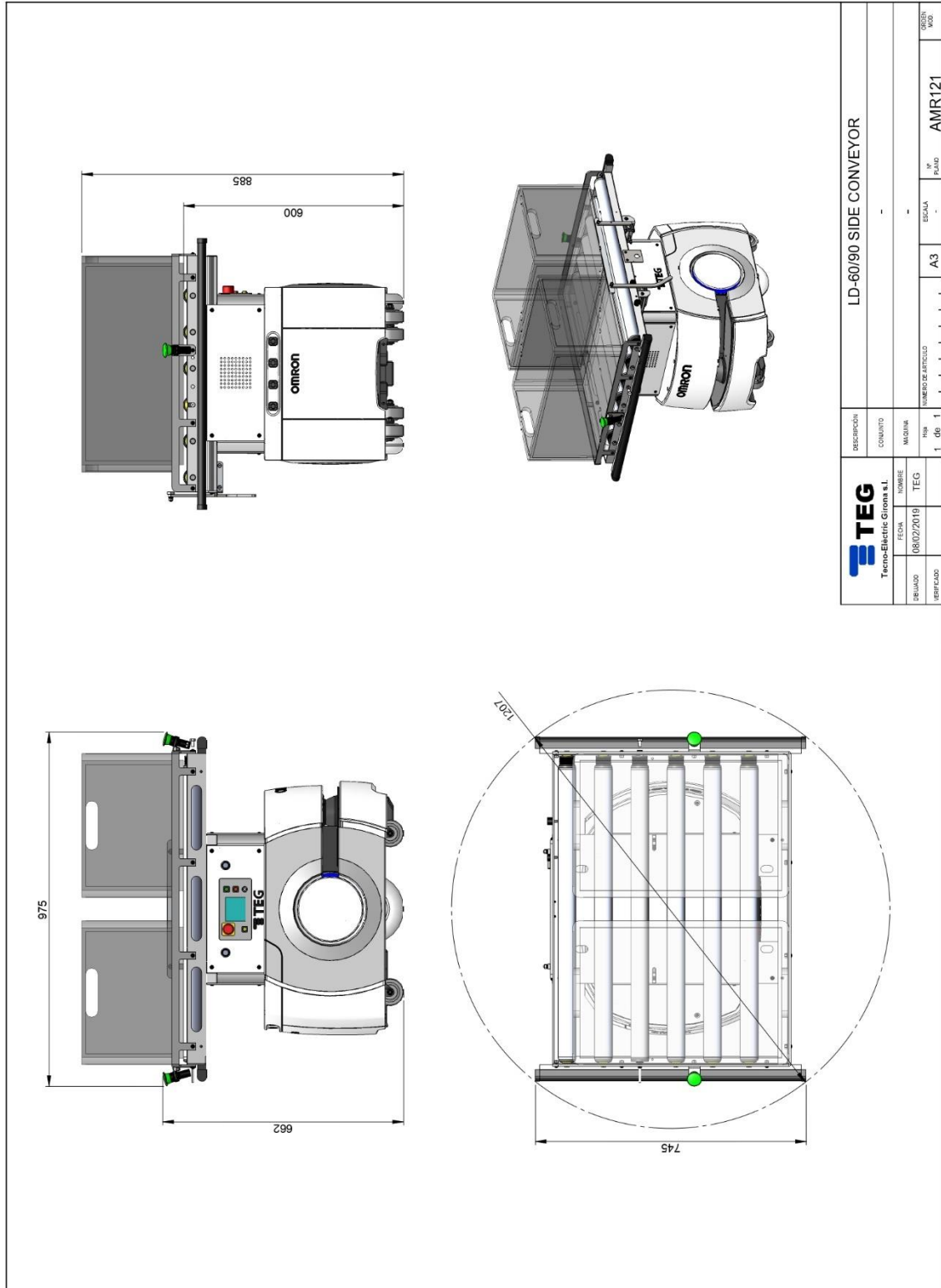

TEG Tecnio-Eléctric Giroma s.l.		DESCRIPCIÓN	LD-60/90 SIDE CONVEYOR			
FECHA	18/02/2019	COMUNTO	-			
DESENHO VERIFICADO		MOVIMA	-			
		Núm	1	06	1	08281
		NÚMERO DE ARTÍCULO	A3		ESCALA	AMR121

Pictures



AMR311 – CART TRANSPORTER

For Omron LD-105CT/LD-130CT

Technical specifications

Special design for adjusting the payload volume.

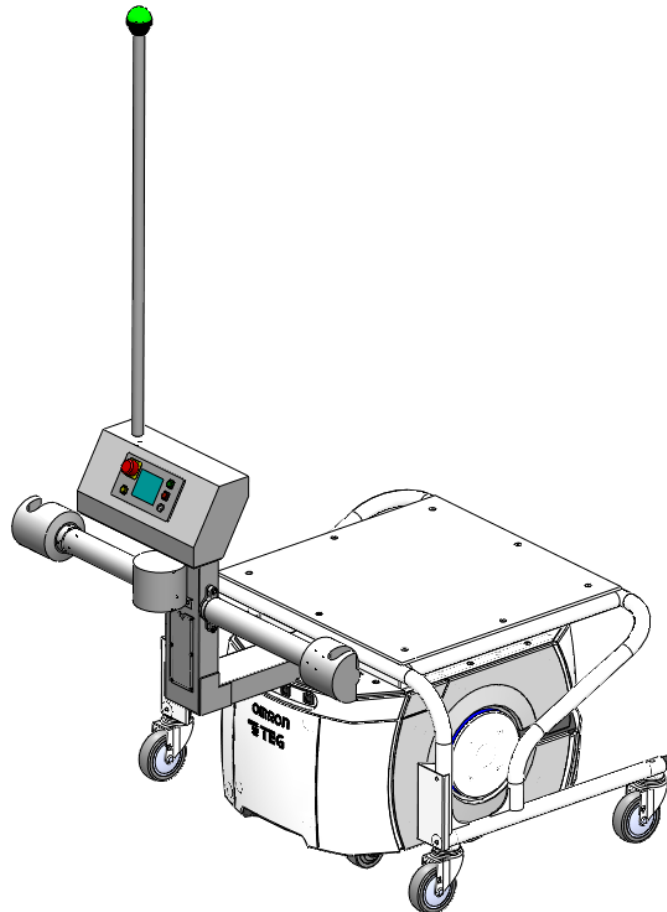

- Increased back length (configurable)
- Beacon height increased (configurable)
- Materials: Aluminium
- Color: White
- Side lasers included - reduced width for narrow corridors (configurable)
- Standard Cart Transporter operation & payload

Available options

- Acuity

Dimensions

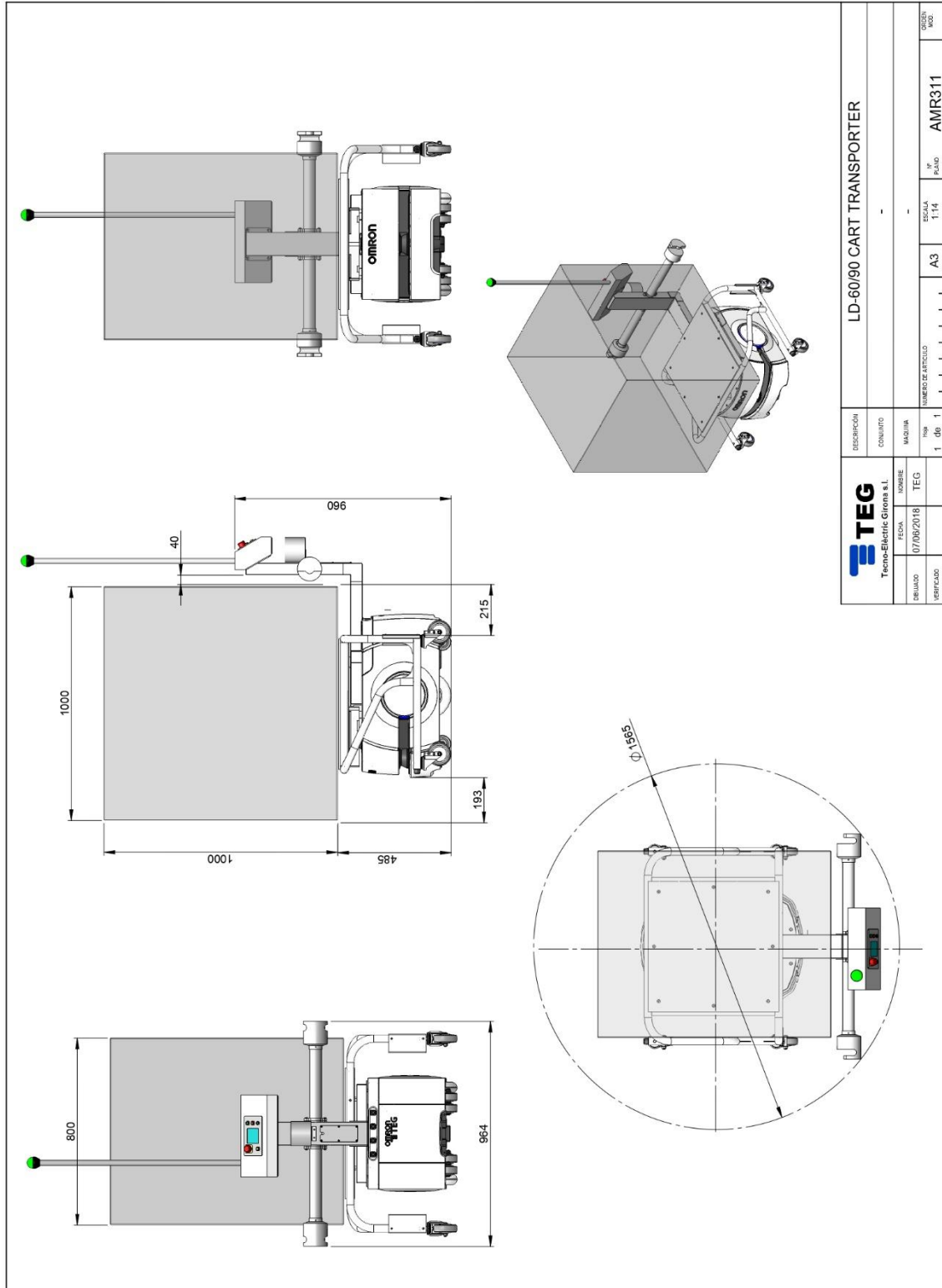

TEG Tecnio-Eléctric Girona s.l.		DESCRIPCIÓN		LD-60/90 CART TRANSPORTER	
FECHA	07/08/2016	COMUNTO	-		
REVISADO	VERIFICADO	MAQUINA	-		
TEG	TEG	IMP	-		
1	1	NÚMERO DE ARTÍCULO	A3	ESCALA	1:14
				PLANO	AMR311
				ORDEN	MOD.

Pictures



AMR321 – CART TRANSPORTER BACKWARD

For Omron LD-250

Technical specifications

Special design for backwards cart operations.



- Backward pickup/dropoff for carts with CAPS positioning plate onboard
- Materials: Steel and stainless steel
- Color: Black and gray
- Configurable cart payload dimensions
- Controlled by Sysmac
- Configurable, stainless steel pushbuttons

Available options

- Side lasers with configurable total width
- Acuity
- Beacon
- Extra pushbuttons
- **TEG POA811** CAPS-onboard cart or customized cart

Dimensions

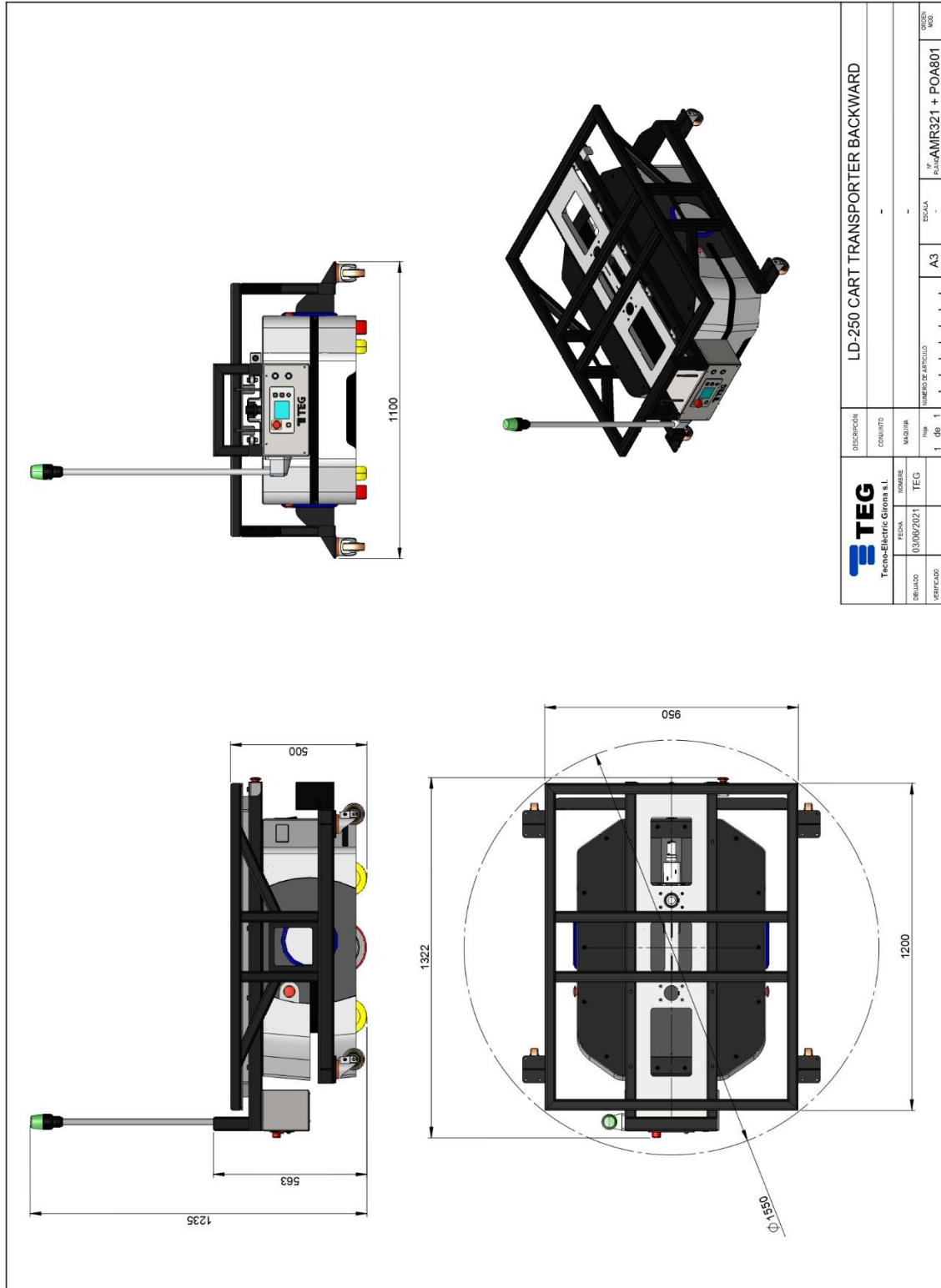

TEG Tecnio-Eléctric Girona s.l.		DESCRIPCIÓN	LD-250 CART TRANSPORTER BACKWARD	
FECHA	10/06/2021	CONJUNTO	-	
NOMBRE	TEG	MAQUINA	-	
DESENHO	VERIFICADO	Nº	1	06
		Nº DE PIEZAS	1	
		ESCALA	-	
		Nº DE PIEZAS/AMR321 + POA801	A3	
		ORDEN MOD.		

Pictures



AMR331 – CART TRANSPORTER FORWARD

For Omron LD-250

Technical specifications

Special design for stand-alone operation.

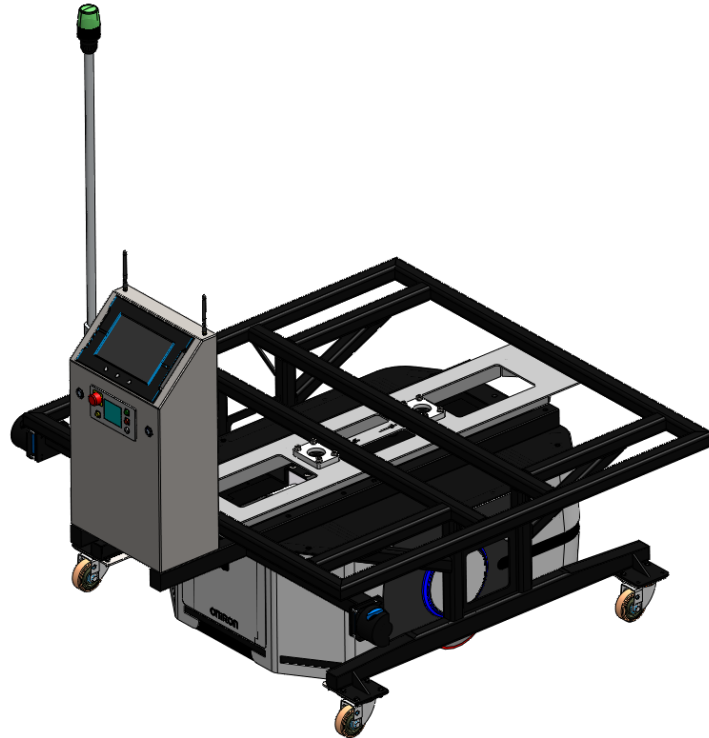

- Forward pickup/dropoff
- Materials: Steel and stainless steel
- Color: Black and gray
- Configurable cart payload dimensions
- Controlled by Sysmac
- Configurable, stainless steel pushbuttons

Available options

- Side lasers with configurable total width
- Rear laser
- Acuity
- Beacon
- Extra pushbuttons
- Omron NA touchscreen
- **TEG POA811** symmetrical cart or customized cart

Dimensions

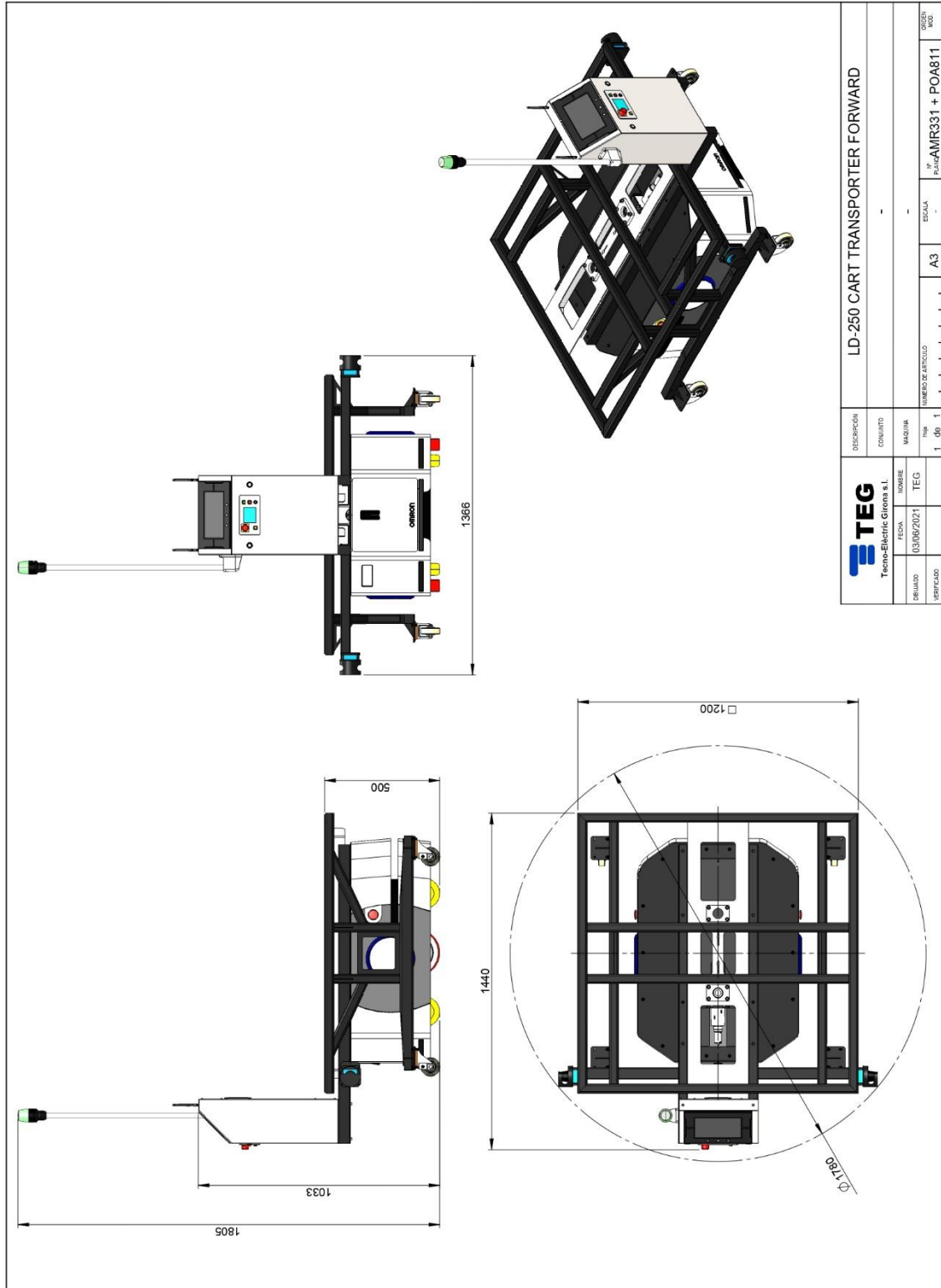

Pictures



AMR411 – PALLET LIFT HANDLER

For Omron LD-250

Technical specifications

Special design for pallet transportation.

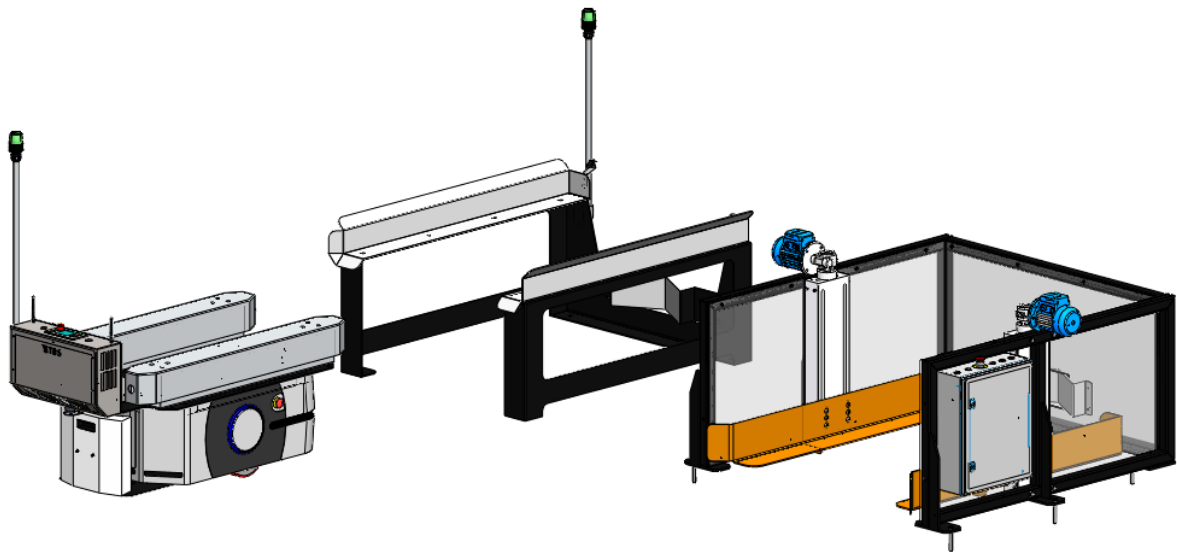

- Forward pickup/dropoff
- Pickup/dropoff with tables and/or special conveyors
- Steel, stainless steel and aluminium structure
- Black and gray colors
- Configurable pallet dimensions
- Controlled by Sysmac
- Configurable, stainless steel pushbuttons

Available options

- Side lasers with configurable total width
- Rear laser
- Acuity
- Beacon
- Extra pushbuttons
- Omron NA touchscreen
- **TEG POA901** fixed table
- **TEG POA911** lift table
- Customized conveyor

Dimensions

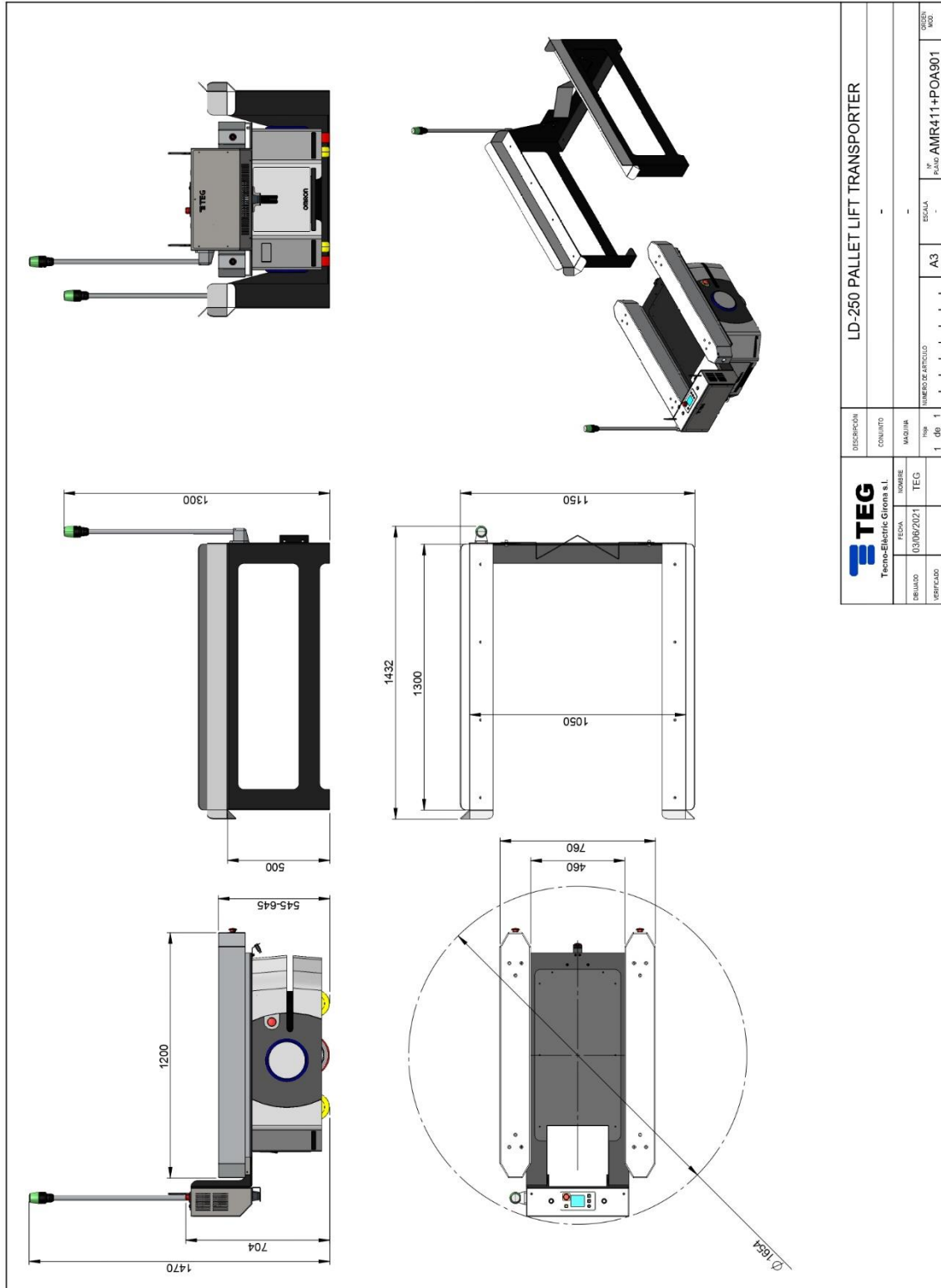

TEG Tecnio-Eléctric Girona s.l.		DESCRIPCIÓN	LD-250 PALLET LIFT TRANSPORTER	
DELIBADO	VERIFICADO	CONSULTO		
FECHA	NOMBRE	MAQUINA		
10/06/2021	TEG	NUM.		
		1	06	1
		NÚMERO DE PIECE	ESCALA	ORDEN MOD.
			A3	AMR411+POA901

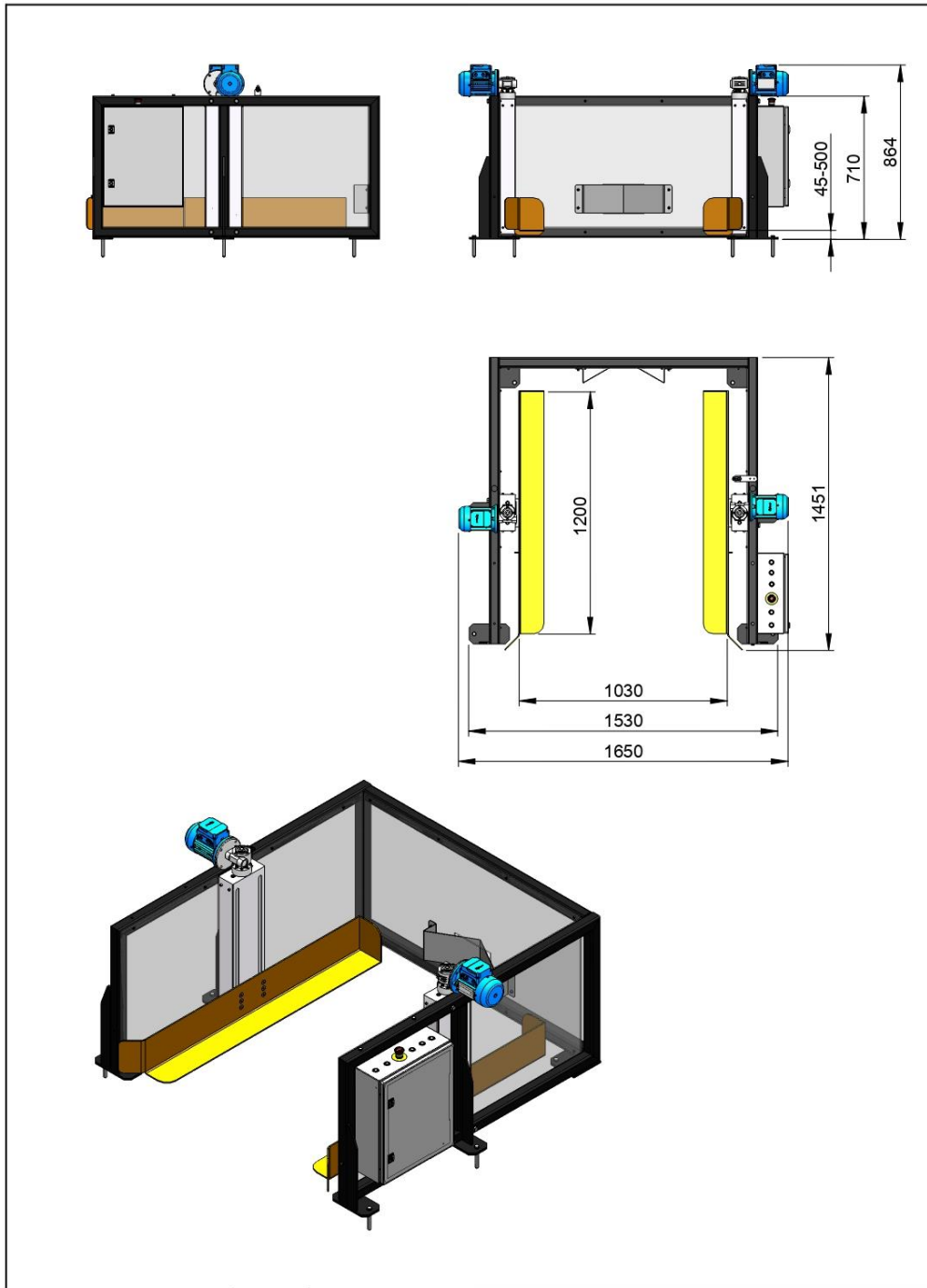

 TEG Tecno-Eléctric Girona s.l.			DESCRIPCIÓN	AUTOMATIC PALLET LIFTER 1200X1000					
			CONJUNTO	-					
DIBUJADO	FECHA	NOMBRE	MAQUINA	-					
VERIFICADO			Hoja	NUMERO DE ARTICULO	A4	ESCALA	Nº PLANO	POA911	ORDEN MOD.
			1 de 1			-			

Pictures

