

3G3M1-ECT

Variable Speed Drives

The Integrated Global Solution

- IM and PM motor control in OLV & CLV (200% torque at 0Hz).
- Multiple ratings: HHD 150%/1 min and HND 120%/1 min.
- 590 Hz max Output frequency
- Torque control for IM in OLV/CLV, PM in CLV.
- Speed, Position and Gear function.
- Flexible EtherCAT configuration: Standard and Ring topology.
- Built-in 1 encoder / pulse counter input.
- Safe Stop 0 (STO SIL3 PLe) wired and FSoE
- 24 VDC backup supply for control board.
- USB programming port.
- Program download without power supply
- Predictive maintenance drive parameters.
- Energy saving dedicated functionality.
- PC configuration tool: Sysmac Studio IDE
- Coated PCB for dust and moisture resistance.
- 10 years 24/7 Maintenance Free operation
- CE,UKCA, cULus, KC, RCM and RoHS.

Ratings:

200 V Class single-phase	0.2 to 3.7 KW
200 V Class three-phase	0.2 to 18.5 KW
400 V Class three-phase	0.4 to 22 KW



System configuration

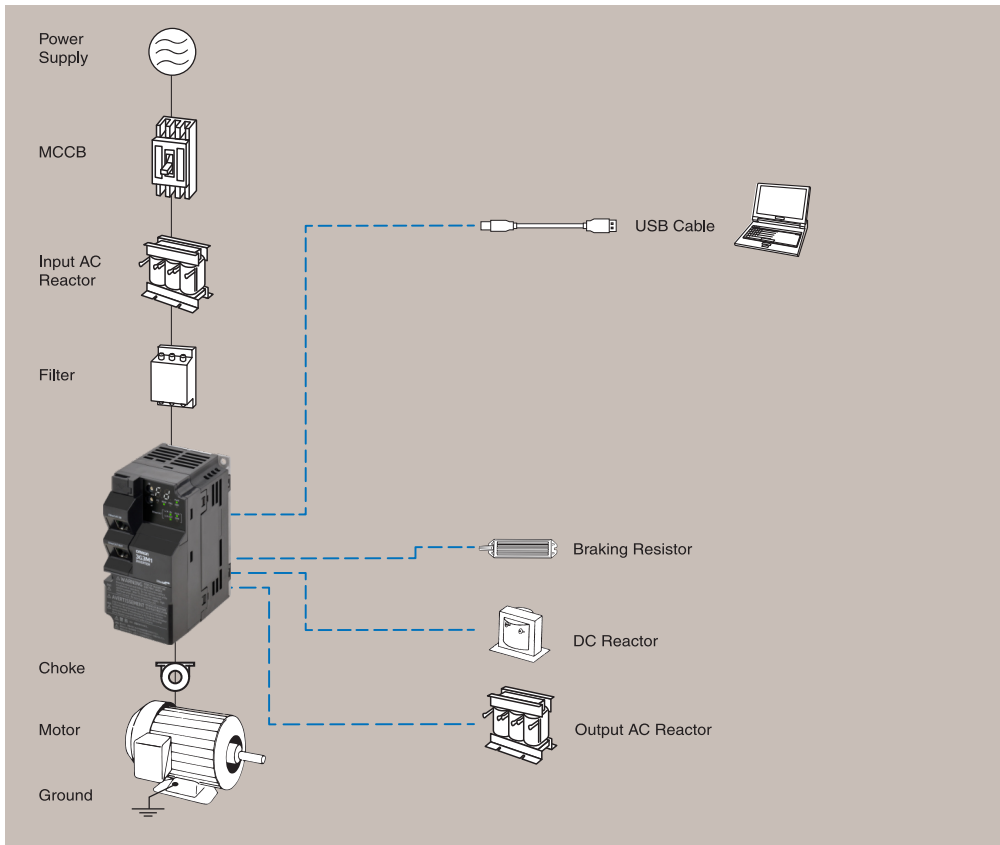

Type designation

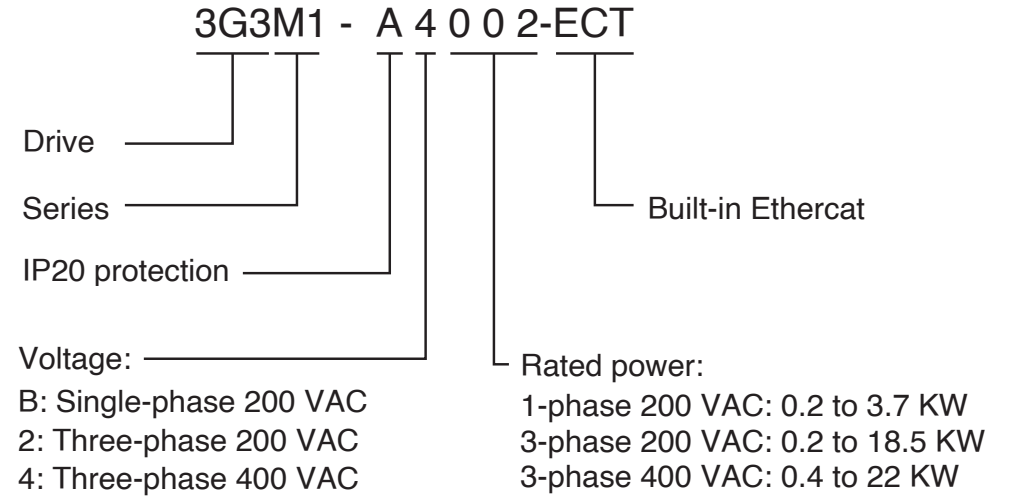

Specifications

Single-phase 200V: 3G3M1-A_-ECT		Duty rating	B002	B004	B007	B015	B022	B037
Max. Applicable motor output (kW)		HHD	0.2	0.4	0.75	1.5	2.2	3.7
		HND	0.4	0.55	1.1	2.0	2.7	-
Output characteristics	Drive capacity (kVA) 200V	HHD	0.6	1	1.7	2.8	3.8	6.1
		HND	0.7	1.2	2.1	3.3	4.2	-
	Drive capacity (kVA) 240V	HHD	0.7	1.2	2.1	3.3	4.6	7.3
		HND	0.8	1.5	2.5	4.0	5.0	-
	Rated output current (A)	HHD	1.6	3.0	5.0	8.0	11.0	17.5
		HND	1.9	3.5*	6.0*	9.6*	12.0*	-
	Overload tolerance	HHD HND	150% of the rated output current for 60 seconds or 200% 0.5s 120% of the rated output current for 60 seconds					
	Carrier frequency (no-derating)	HHD HND	4 kHz 8 kHz					
Max. Output voltage	-	Three-phase 200 to 240 V (with AVR)						
Max. Output frequency	-	590.0 Hz						
Input characteristics	Rated voltage and frequency	-	1-phase AC power supply 200-240 V at 50/60 Hz					
	Allowable voltage fluctuation	-	-15% to 10%					
	Allowable frequency fluctuation	-	±5%					
	Rated input current	HHD	3.3	5.4	9.7	16.4	22.0	45.4
HND		4.9	7.3	13.8	20.2	26.0	-	
Rated Input current with DC reactor	HHD	2.0	3.5	6.4	11.6	17.5	31.8	
	HND	3.7	4.6	9.4	17.9	25.0	-	
Rated power capacity	HHD	0.4	0.7	1.3	2.4	3.5	6.4	
	HND	0.8	1.0	1.9	3.6	5.5	-	
Braking	Natural deceleration braking torque (%) without resistor	HHD	150	100	70	40		
		HND	75	73	68	48	29	-
	Minimum connectable resistor (Ohms)	-	100		40			
Weight (kg)		-	0.5	0.6	0.9	1.4	1.7	3.8

*1. Values for 40°C ambient temperature

Note “Applicable motor” represents standard three phase motors.

When using other types of motors, make sure that the rated current of the motor does not exceed that of the inverter output voltage cannot exceed the power supply voltage.

For higher carrier frequency confirm with carrier derating tables in the manual the value is calculated assuming that the inverter is connected with a power supply with the capacity of 500 kVA (or 10 times the inverter capacity if the inverter capacity exceeds 50 kVA) and %X is 5%

3-phase 200 V: 3G3M1-A_-ECT		Duty rating	2002	2004	2007	2015	2022	2037	2055	2075	2110	2150	2185
Max. Applicable motor output (kW)	HHD	0.2	0.4	0.75	1.5	2.2	3.7	5.5	7.5	11	15	18.5	
	HND	0.4	0.75	1.1	2.2	3.0	5.5	7.5	11	15	18.5	22	
Output characteristics	Drive capacity (kVA) 200V	HHD	0.6	1.0	1.7	2.8	3.8	6.1	8.7	11	16	21	26
		HND	0.7	1.2	2.1	3.3	4.2	6.8	10	14	19	24	30
	Drive capacity (kVA) 240V	HHD	0.7	1.2	2.1	3.3	4.6	7.3	10	14	20	25	32
		HND	0.8	1.5	2.5	4.0	5.0	8.1	12	17	23	29	37
	Rated output current (A)	HHD	1.6	3.0	5.0	8.0	11	17.5	25	33	47	60	76
		HND	2.0	3.5	6.0	9.6	12*	19.6*	30	40	56	69	88
Overload tolerance	HHD HND	150% of the rated output current for 60 seconds or 200% 0.5s 120% of the rated output current for 60 seconds											
Carrier frequency (no-derating)	HHD HND	4 kHz 8 kHz											
Max. Output voltage	-	Three-phase 200 to 240 V (with AVR)											
Max. Output frequency	-	590.0 Hz											
Rated voltage and frequency	-	3-phase AC power supply 200-240 V at 50/60 Hz											
Allowable voltage fluctuation	-	-15% to 10%											
Allowable frequency fluctuation	-	±5%											
Input characteristics	Rated input current	HHD	1.8	3.1	5.3	9.5	13.2	22.2	31.5	42.7	60.7	80	97
		HND	2.6	4.9	6.7	12.8	17.9	28.5	42.7	60.7	80	97	112
	Rated Input current with DC reactor	HHD	0.93	1.6	3.0	5.7	8.3	14.0	21.1	28.8	42.2	57.6	71.0
		HND	1.6	3.0	4.3	8.3	11.7	19.9	28.8	42.2	57.6	71.0	84.4
	Rated power capacity	HHD	0.4	0.6	1.1	2.0	2.9	4.9	7.0	10	15	20	25
		HND	0.6	1.1	1.5	2.9	4.1	6.9	10	15	20	25	30
Braking	Natural deceleration braking torque (%) without resistor	HHD	150	100		70	40		20				
		HND	75	53	68	48	29	27	15				
	Minimum connectable resistor (Ohms)	-	100			40		33	20	15	10	8.6	4
	Weight (kg)	-	0.5	0.6	0.8	1.4	1.4	1.7	3.8	4	5.3	5.4	11

*1: Values for 40°C ambient temperature

Note “Applicable motor” represents standard three phase motors.

When using other types of motors, make sure that the rated current of the motor does not exceed that of the inverter output voltage cannot exceed the power supply voltage.

For higher carrier frequency confirm with carrier derating tables in the manual the value is calculated assuming that the inverter is connected with a power supply with the capacity of 500 kVA (or 10 times the inverter capacity if the inverter capacity exceeds 50 kVA) and %X is 5%

3-phase 400 V: 3G3M1-A_-ECT		Duty rating	4004	4007	4015	4022	4030	4040	4055	4075	4110	4150	4185	4220	
Max. Applicable motor output (kW)	HD	0.75	1.1	2.2	3.0	4.0	5.5	7.5	11.0	15.0	18.5	22.0	30.0	30.0	
	ND	0.75	1.5	2.2	3.0	4.0	5.5	11.0	15.0	18.5	22.0	30.0	30.0	37.0	
	HHD	0.4	0.75	1.5	2.2	3.0	4.0	5.5	7.5	11.0	15.0	18.5	22.0	22.0	
	HND	0.75	1.1	2.2	3.0*	4.0	5.5*	7.5	11.0	15.0	18.5	22.0	30.0	30.0	
Output characteristics	Drive capacity (kVA) 380V	HD	1.2	2.2	3.3	4.1	5.8	7.3	12.0	15.0	20.0	25.0	30.0	39.9	39.9
		ND	1.4	2.7	3.6	4.5	6.1	7.9	14.0	19.0	24.0	29.0	39.0	47.0	47.0
		HHD	1.2	2.2	3.2	3.6	4.7	6.1	9.7	12.0	16.0	20.0	26.0	30.0	30.0
		HND	1.4	2.7	3.6	4.5	5.8	7.3	12.0	15.0	20.0	25.0	30.0	39.0	39.0
	Drive capacity (kVA) 480V	HD	1.5	2.8	4.2	5.2	7.3	9.2	15.0	19.0	26.0	32.0	37.0	50.0	50.0
		ND	1.7	3.4	4.6	5.7	7.6	10.0	18.0	24.0	31.0	37.0	49.0	60.0	60.0
		HHD	1.5	2.8	4.0	4.6	6.0	7.6	12.3	15.0	20.0	26.0	32.0	37.0	37.0
		HND	1.7	3.4	4.6	5.7	7.3	9.2	15.0	19.0	26.0	32.0	37.0	50.0	50.0
	Rated output current (A)	HD	1.8	3.4	5.0	6.3	8.6	11.1	17.5	23.0	31.0	38.0	45.0	60.0	60.0
		ND	2.1	4.1	5.5	6.9	9.2	12.0	21.5	28.5	37.0	44.0	59.0	72.0	72.0
		HHD	1.8	3.4	4.8	5.5	7.2	9.2	14.8	18.0	24.0	31.0	39.0	45.0	45.0
		HND	2.1	4.1	5.5	6.9	8.8	11.1	17.5	23.0	31.0	38.0	45.0	60.0	60.0
Overload tolerance	HHD HND	150% of the rated output current for 60 seconds or 200% 0.5s, 120% of the rated output current for 60 seconds													
Carrier frequency (no-derating)	HHD HND	4 kHz 8 kHz													
Max. Output voltage		Proportional to input voltage: 380 - 480 V													
Max. Output frequency		590.0 Hz													
Rated voltage and frequency	-	3-phase AC power supply 380-480 V at 50/60 Hz													
Allowable voltage fluctuation		-15% to 10%													
Allowable frequency fluctuation		±5%													
Input characteristics	Rated input current	HD	2.7	3.9	7.3	11.3	14.2	16.8	23.2	33.0	43.8	52.3	60.6	77.9	77.9
		ND	2.7	4.8	7.3	11.3	14.2	16.8	33.0	43.8	52.3	60.6	77.9	94.3	94.3
		HHD	1.7	3.1	5.9	8.2	11.3	14.2	17.3	23.2	33.0	43.8	52.3	60.6	60.6
		HND	2.7	3.9	7.3	11.3	14.2	16.8	23.2	33.0	43.8	52.3	60.6	77.9	77.9
	Rated Input current with DC reactor	HD	1.5	2.1	4.2	5.6	7.7	10.1	14.4	21.1	28.8	35.5	42.2	57.0	57.0
		ND	1.5	2.9	4.2	5.8	7.7	10.1	21.1	28.8	35.5	42.2	57.0	68.5	68.5
		HHD	0.85	1.6	3.0	4.4	5.8	7.7	10.6	14.4	21.1	28.8	35.5	42.2	42.2
		HND	1.5	2.1	4.2	5.8	7.7	10.1	14.4	21.1	28.8	35.5	42.2	57.0	57.0
	Rated power capacity	HD	1.1	1.5	3.0	4.1	5.4	7.0	10.0	15.0	20.0	29.0	39.0	47.0	47.0
		ND	1.1	2.1	3.0	4.1	5.4	7.0	15.0	20.0	25.0	29.0	39.0	47.0	47.0
		HHD	0.6	1.2	2.1	3.1	4.1	5.4	7.3	10.0	15.0	20.0	25.0	29.0	29.0
		HND	1.1	1.5	3.0	4.1	5.4	7.0	10.0	15.0	20.0	25.0	29.0	39.0	39.0
	Braking	Natural deceleration braking torque (%) without resistor	HD	53	68	48	29	27	15						
			ND	53	50	48	29	27	12						
			HHD	100	70	40	40	20							
			HND	53	68	48	29	27	15						
Minimum connectable resistor (Ohms)	-	200	160	130	80	60	40	34.4	16						
Weight (kg)	-	1.2	1.4	1.5	1.4	1.8	1.8	3.7	3.8	5.3	5.4	11	11		

*1: Values for 40°C ambient temperature

Note “Applicable motor” represents standard three phase motors.
 When using other types of motors, make sure that the rated current of the motor does not exceed that of the inverter output voltage cannot exceed the power supply voltage.
 For higher carrier frequency confirm with carrier derating tables in the manual the value is calculated assuming that the inverter is connected with a power supply with the capacity of 500 kVA (or 10 times the inverter capacity if the inverter capacity exceeds 50 kVA) and %X is 5%

Common specifications

Model number 3G3M1-A _ECT		Specifications
Control functions	Control methods	V/f, Dynamic torque vector and vector control with and without feedback.
	Motor support	Asynchronous Induction motor Permanent Magnet synchronous motor (Only Vector control with and without feedback)
	Frequency control range	0.00 to 590.0 Hz
	Frequency tolerance	Digital inputs: $\pm 0.01\%$ of the max. output frequency Analog inputs: $\pm 0.2\%$ of the max. output frequency (25 ± 10 °C)
	Frequency setting resolution	Digital inputs: 0.01 Hz Analog inputs: Maximum frequency $\times 5/10,000$ Communication setting: 0.005% of the maximum output frequency or 0.01 Hz (fixed)
	Output frequency resolution	0.001 Hz
	Frequency setting signal	Main speed freq reference: -10 to 10 VDC (22 k Ω)
	Starting torque	V/f: 150%/10% of rated speed 200% /0.5Hz Vector without sensor or V/f with feedback 200%/0.0 Hz Vector with feedback
	Speed control range	1:100 V/f mode 1:200 Dynamic torque vector without feedback / vector without feedback / V/f with feedback 1:500 Dynamic torque vector with feedback 1:1500 Vector control with feedback
	Zero speed control	Vector with feedback
	Torque limits	4 quadrant and 4 independent settings
	Accel/Decel Time	0.00 to 6000s (the drive can set two pairs of different acceleration and deceleration times)
	Functionality	Protective functions
Main control functions		Torque boost, AVR control, Energy saving, Motor sound, slip compensation, DC injection, Frequency auto-search, current limiter, ASR control, zero speed control servo lock, heavy deceleration brake, pre-excitation, Positioning, Master-Slave follower, overload stop, second motor, brake control,
Environment	Operation ambient temperature	-10 to 50°C (Derating required)
	Storage ambient temperature	-25 to 70°C (Short-time temperature during shipment)
	Operating ambient humidity	5 to 95% (with no condensation)
	Vibration resistance	Vibration Frequency specifications 2 to 9Hz - 3mm (Max. Amplitude) 9 to 20 Hz - 1G 20 to 55 Hz - 0.2G 55 to 200 Hz - 0.1G
	Location	Maximum altitude of 1,000 m, indoors (without corrosive gases or dust). From 1,000 to 3,000 a derating of 0,6% every 100m should be applied.

Standards

3G3M1-A_-ECT		Specifications	
Regulations and Standards	CE UKCA	EMC	EN 61800-3:2004/A1:2012 (2018 is ratified)
		Functional safety	IEC 61800-5-2:2016 IEC/EN 61800-5-2:2017 STO SIL3 EN ISO 13849-1:2015, Cat.3 / Ple (2016 already exist)
		Electrical safety	EN 61800-5-1:2017
	UL	US	UL61800-5-1, Edition 1, 2012 (A1 2017 ratified)
		CA	CSA-C22.2 No.274, 2017
	KC		KS-C9800-3 (Pending)
	EAC		-
	RCM		EN 61800-3:2004+A1:2012 (2016 ratified)
Protection design		Open chassis type: IP20 Model	

Dimensions

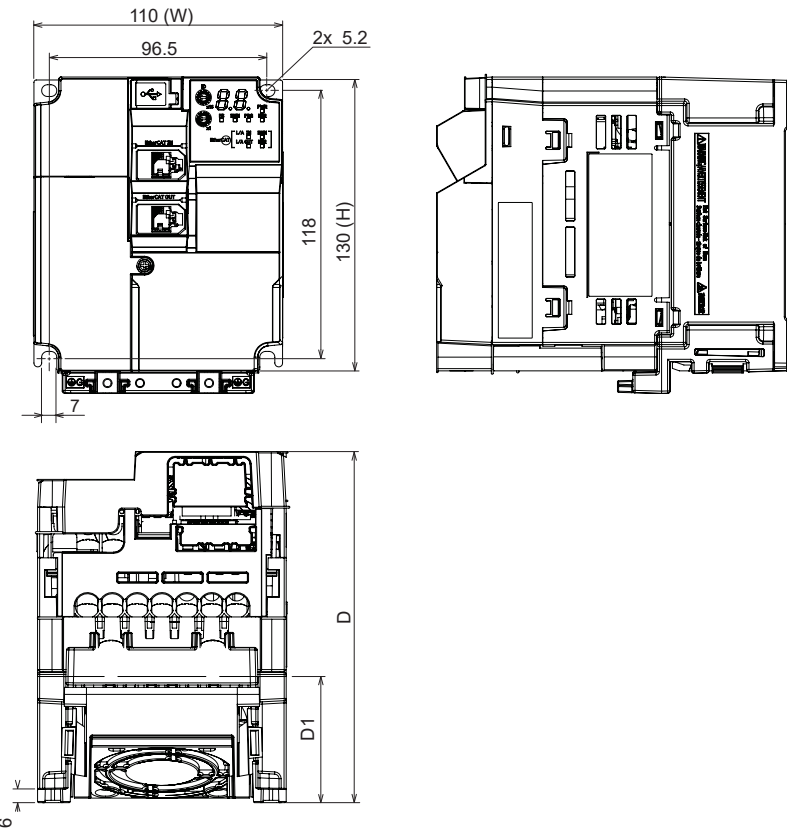
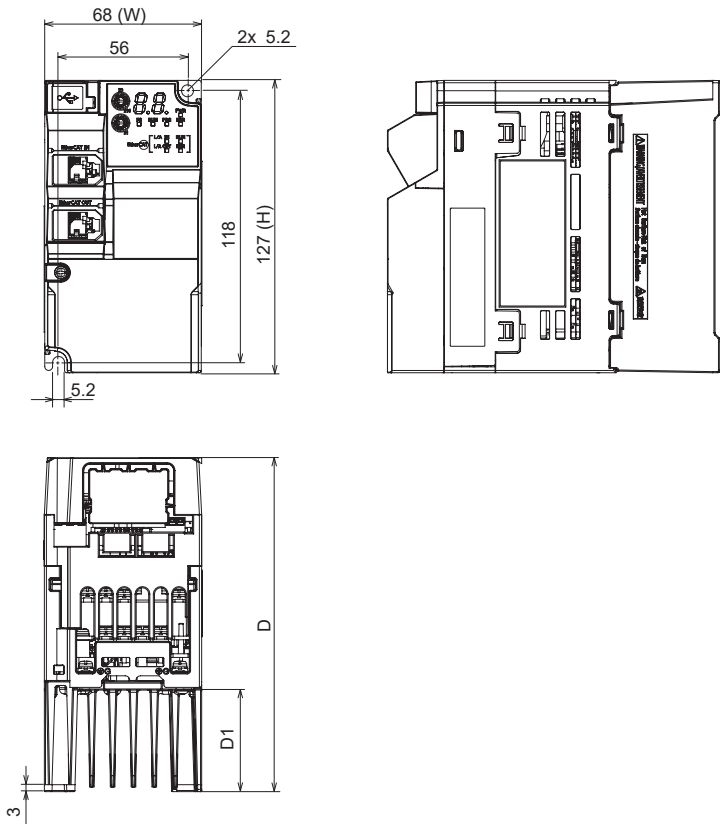

Power supply	Model	W (mm)	H (mm)	D (mm)	D1 (mm)
Single-phase 200V	3G3M1-AB002-ECT	68	127	98	8
	3G3M1-AB004-ECT			120	23
	3G3M1-AB007-ECT			165	48
Three-phase 200V	3G3M1-A2002-ECT	68	127	98	8
	3G3M1-A2004-ECT			113	23
	3G3M1-A2007-ECT			145	48

Power supply	Model	W (mm)	H (mm)	D (mm)	D1 (mm)
Single-phase 200V	3G3M1-AB015-ECT	110	130	166	58
Three-phase 200V	3G3M1-A2015-ECT			156	58
	3G3M1-A2022-ECT				48
Three-phase 200V	3G3M1-A4004-ECT	110	130	132	38
	3G3M1-A4007-ECT			156	58
	3G3M1-A4015-ECT				
	3G3M1-A4022-ECT				

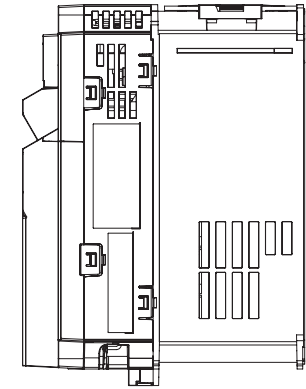
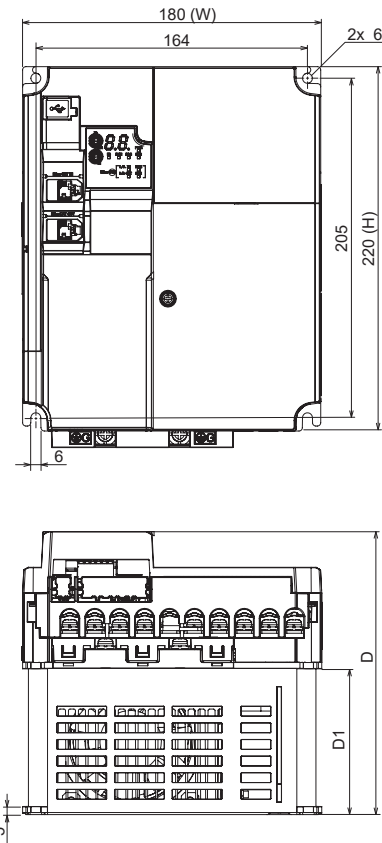
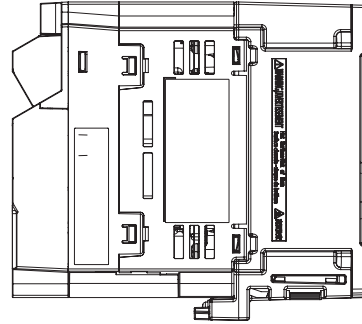
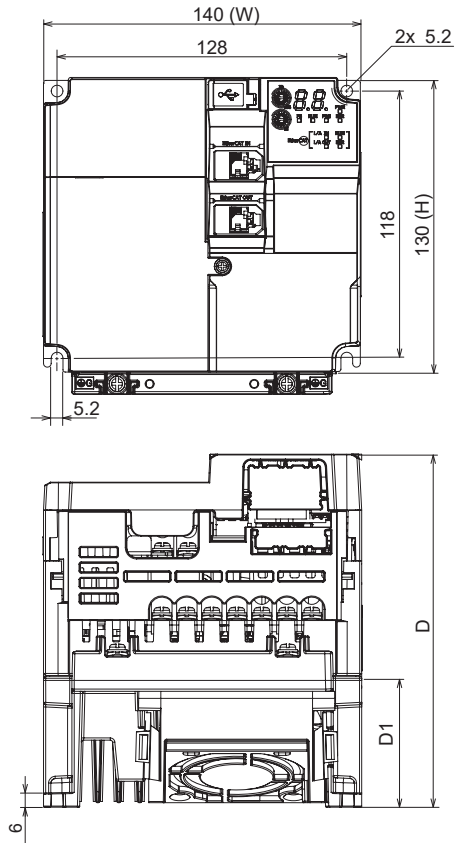

Power supply	Model	W (mm)	H (mm)	D (mm)	D1 (mm)
Single-phase 200 V	3G3M1-AB022-ECT	140	130	156	58
Three-phase 200 V	3G3M1-A2037-ECT				
Three-phase 400V	3G3M1-A4030-ECT				
	3G3M1-A4040-ECT				

Power supply	Model	W (mm)	H (mm)	D (mm)	D1 (mm)
Single-phase 200 V	3G3M1-AB037-ECT	140	130	156	58
Three-phase 200 V	3G3M1-A2055-ECT				
	3G3M1-A2075-ECT				
Three-phase 400 V	3G3M1-A4055-ECT				
	3G3M1-A4075-ECT				

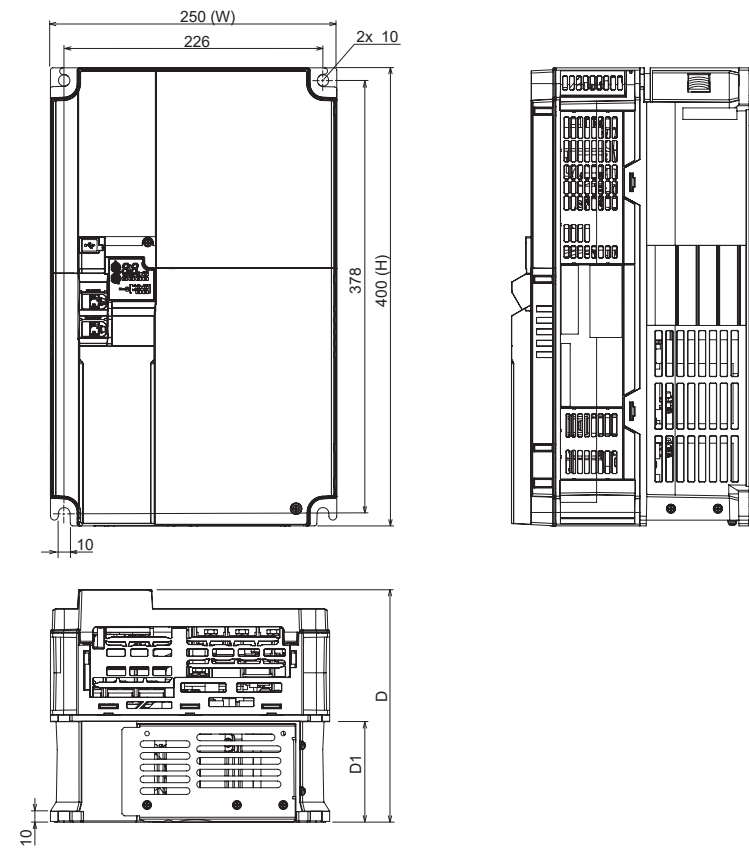
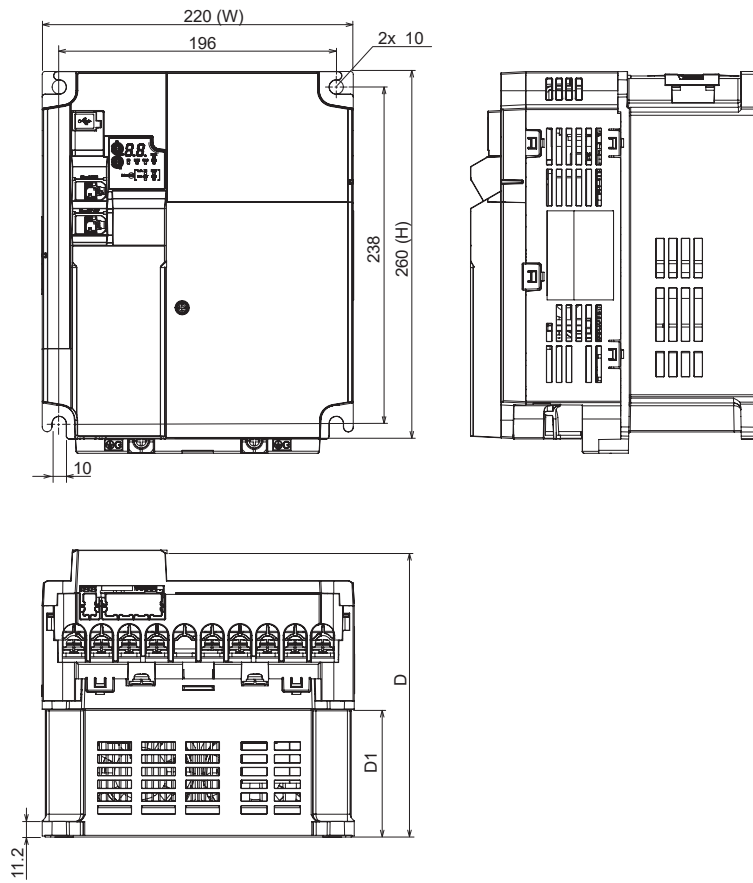

Power supply	Model	W (mm)	H (mm)	D (mm)	D1 (mm)
Three-phase 200 V	3G3M1-A2110-ECT	220	260	203	90
	3G3M1-A2150-ECT				
Three-phase 400 V	3G3M1-A4110-ECT				
	3G3M1-A4150-ECT				

Power supply	Model	W (mm)	H (mm)	D (mm)	D1 (mm)
Three-phase 200 V	3G3M1-A2185-ECT	250	400	203	90
Three-phase 400 V	3G3M1-A4185-ECT				
	3G3M1-A4220-ECT				
	3G3M1-A4220-ECT				

Line filters

Same dimensions for standard and LL version

AX-FIC1014-SE / SE-LL

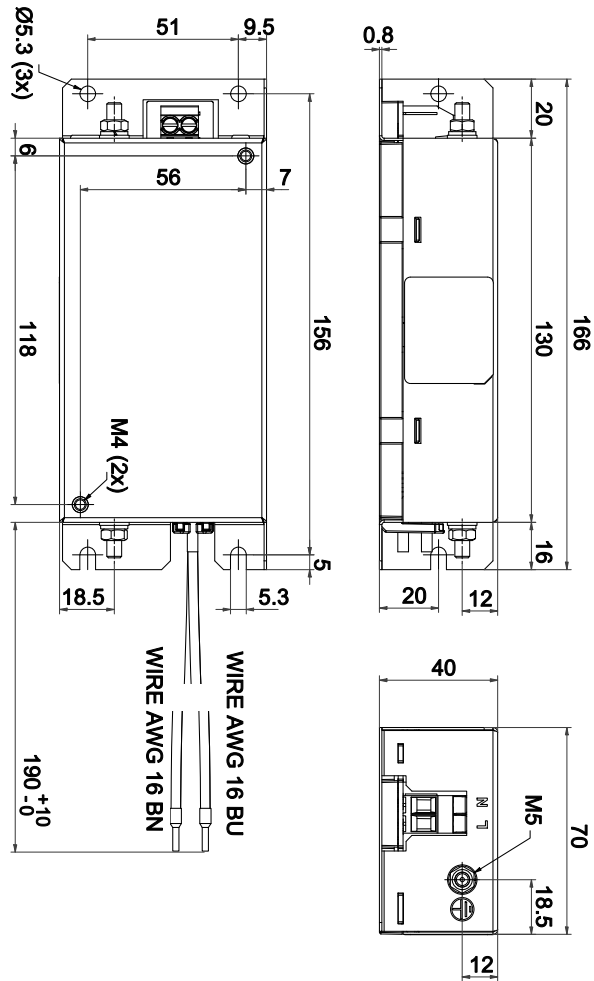

AX-FIC1021-SE / SE-LL

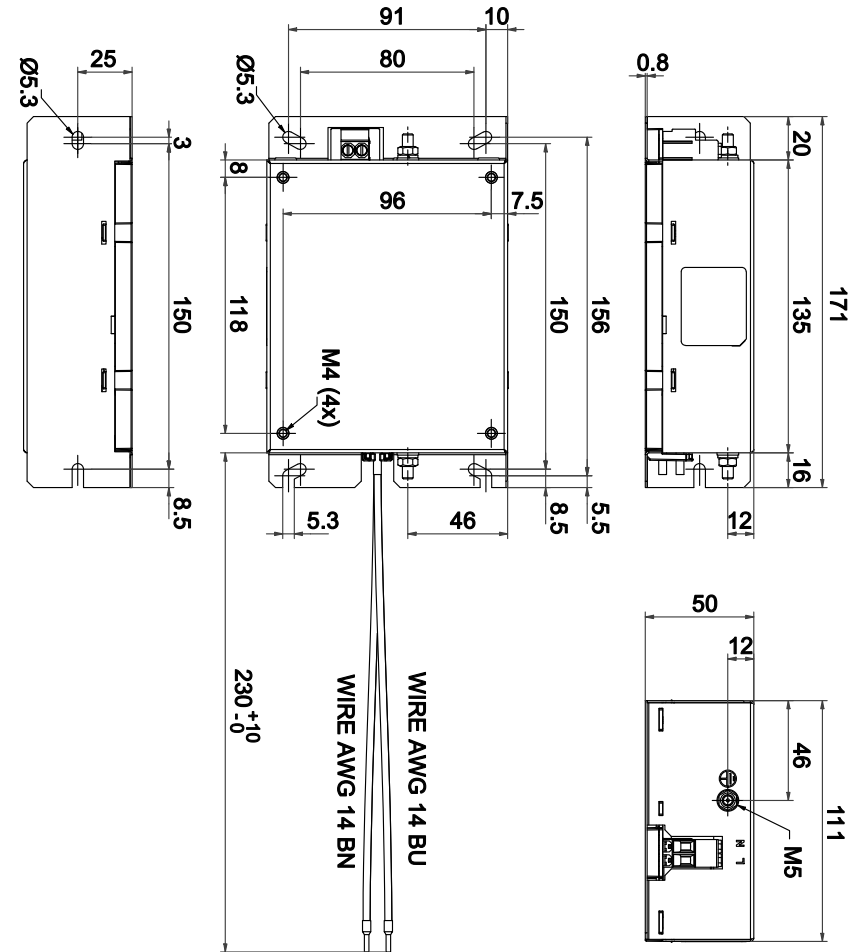

AX-FIC1026-SE / SE-LL

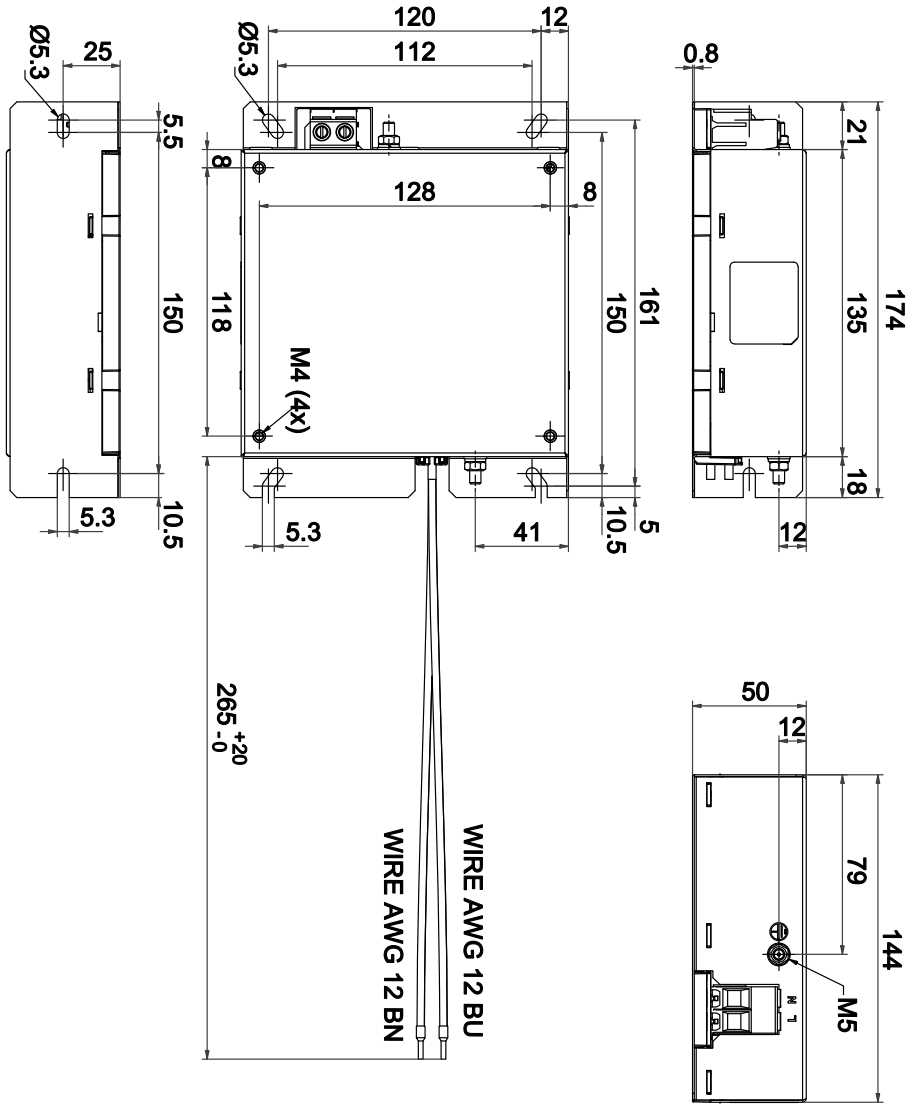

AX-FIC1045-SE / SE-LL

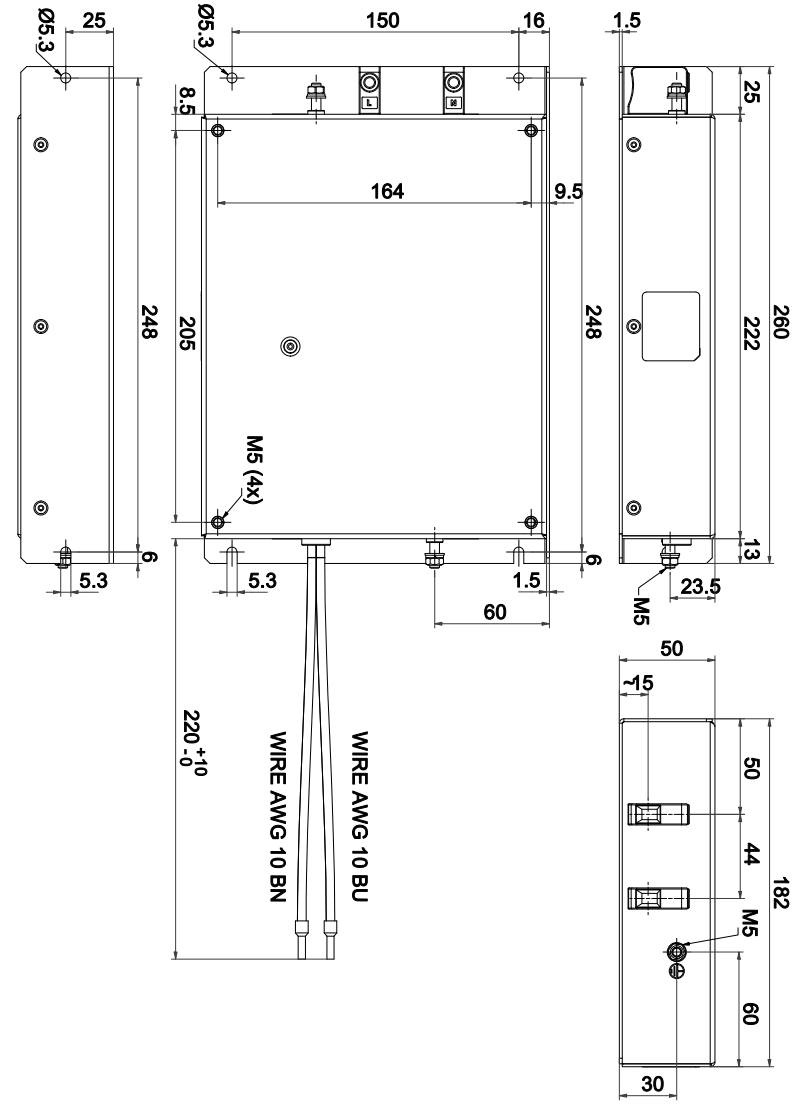

AX-FIC4004-SE / SE-LL

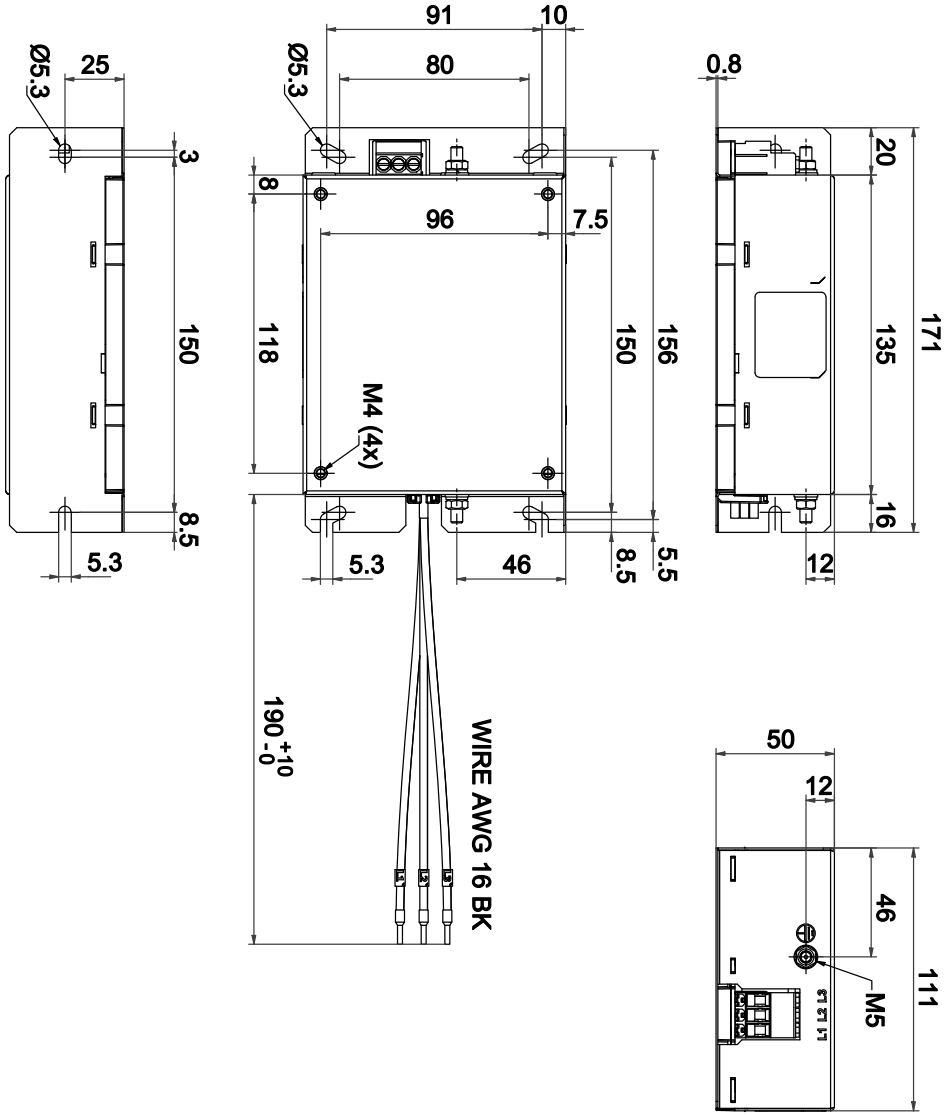

AX-FIC4011-SE / SE-LL

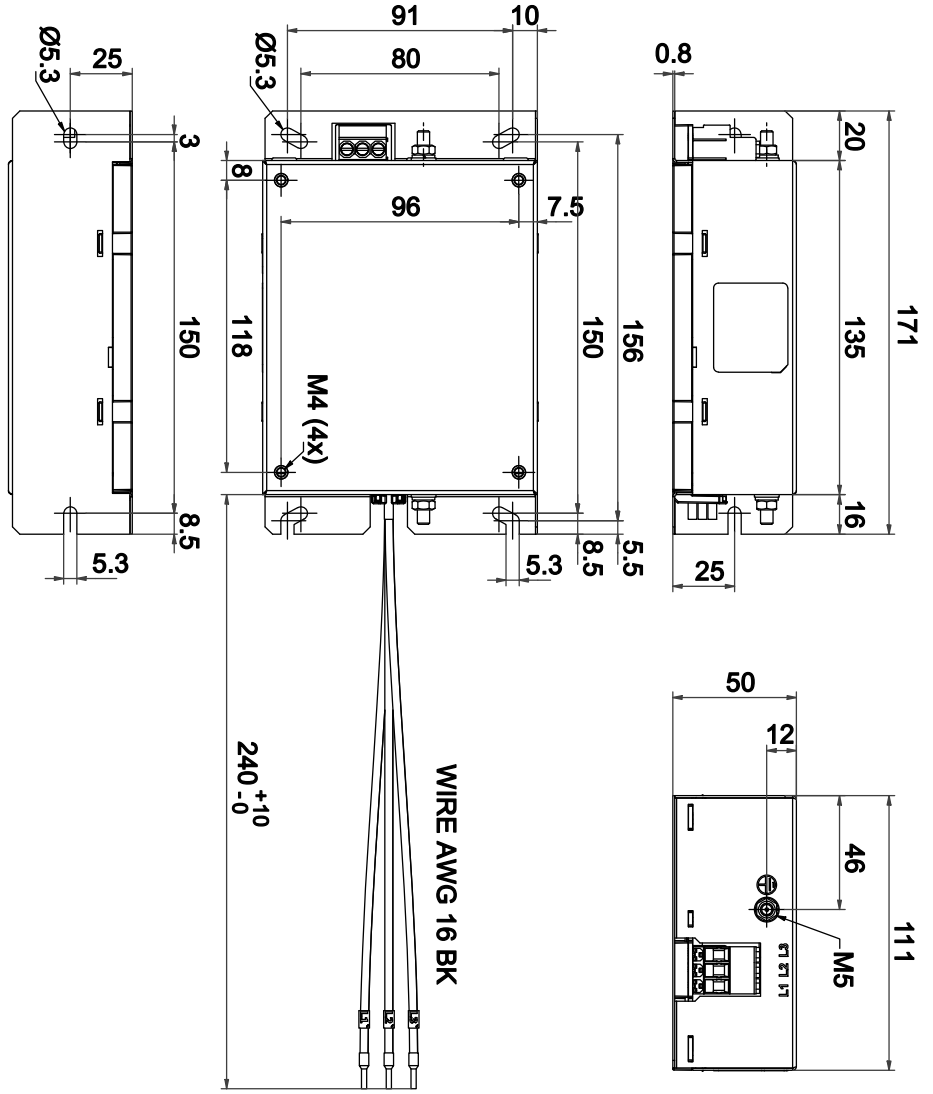

AX-FIC4017-SE / SE-LL

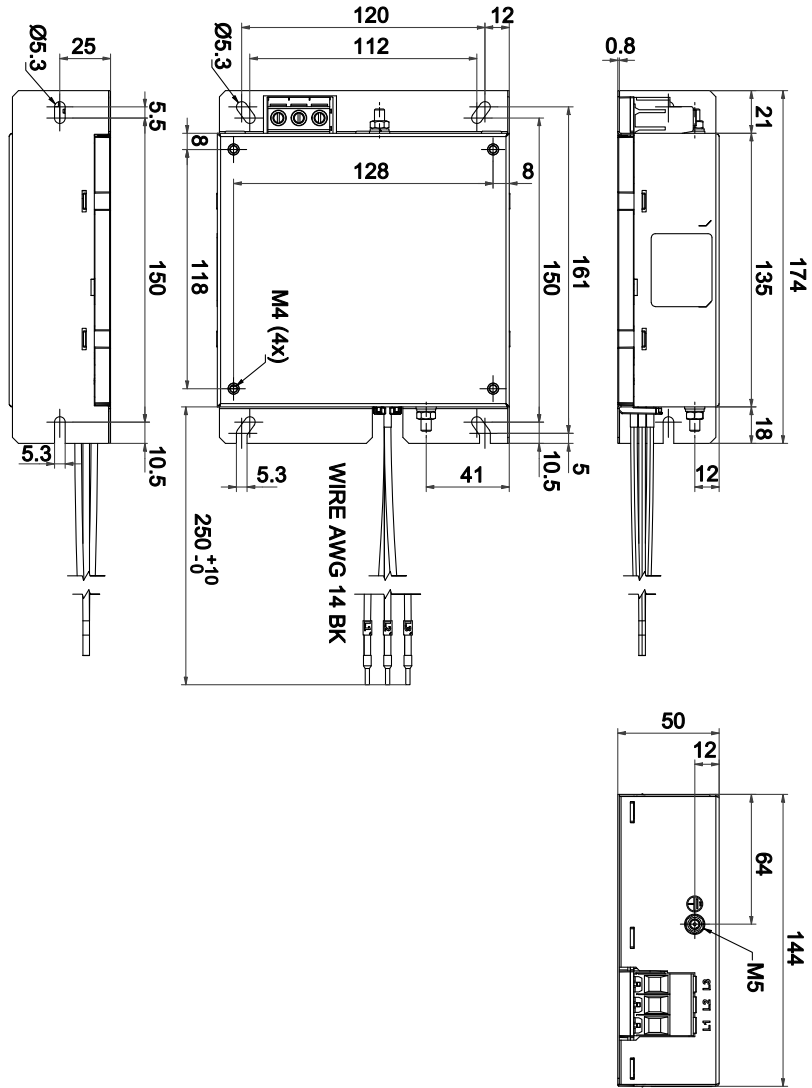

AX-FIC4044-SE / SE-LL

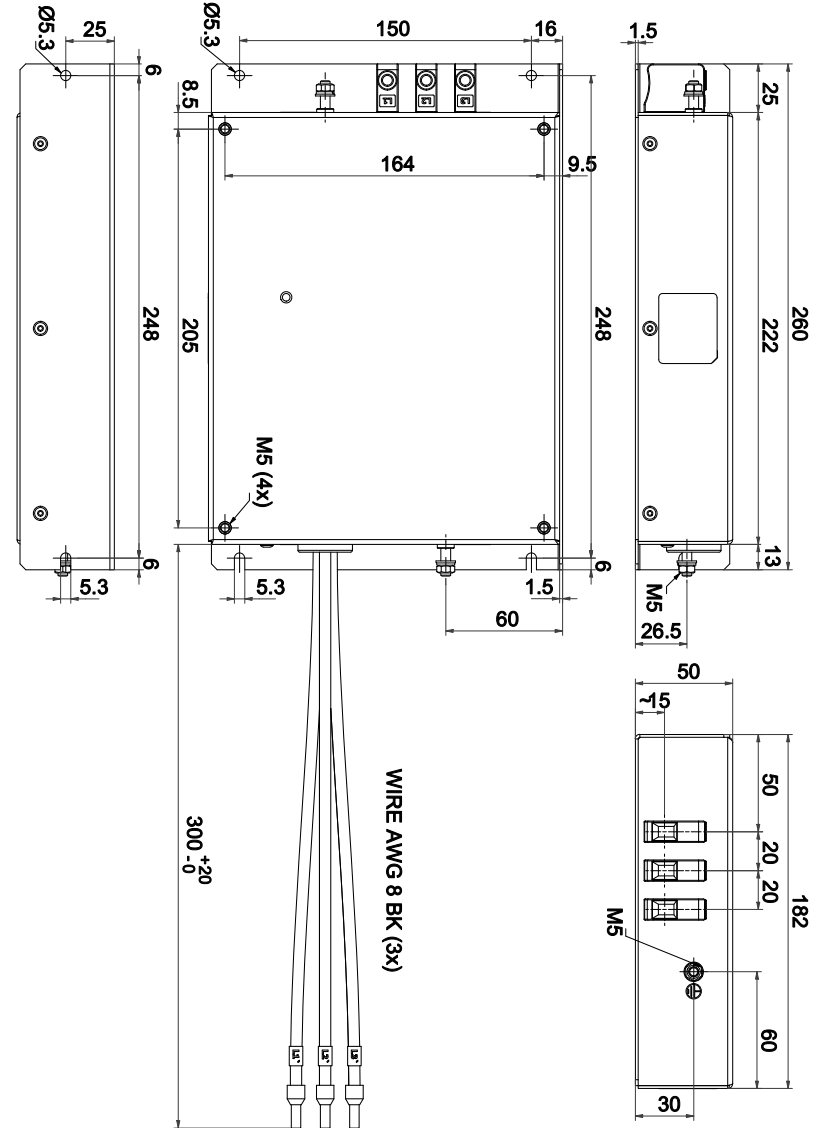

AX-FIC4061-SE / SE-LL

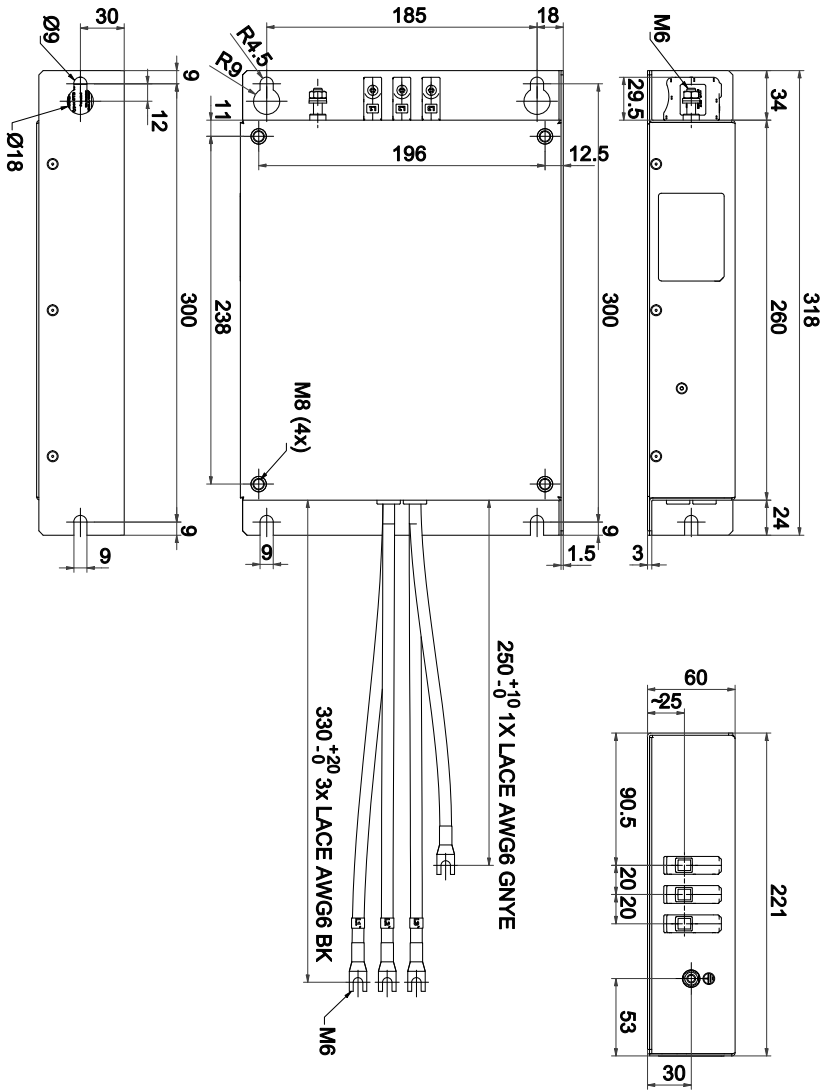

AX-FIC4095-SE / SE-LL

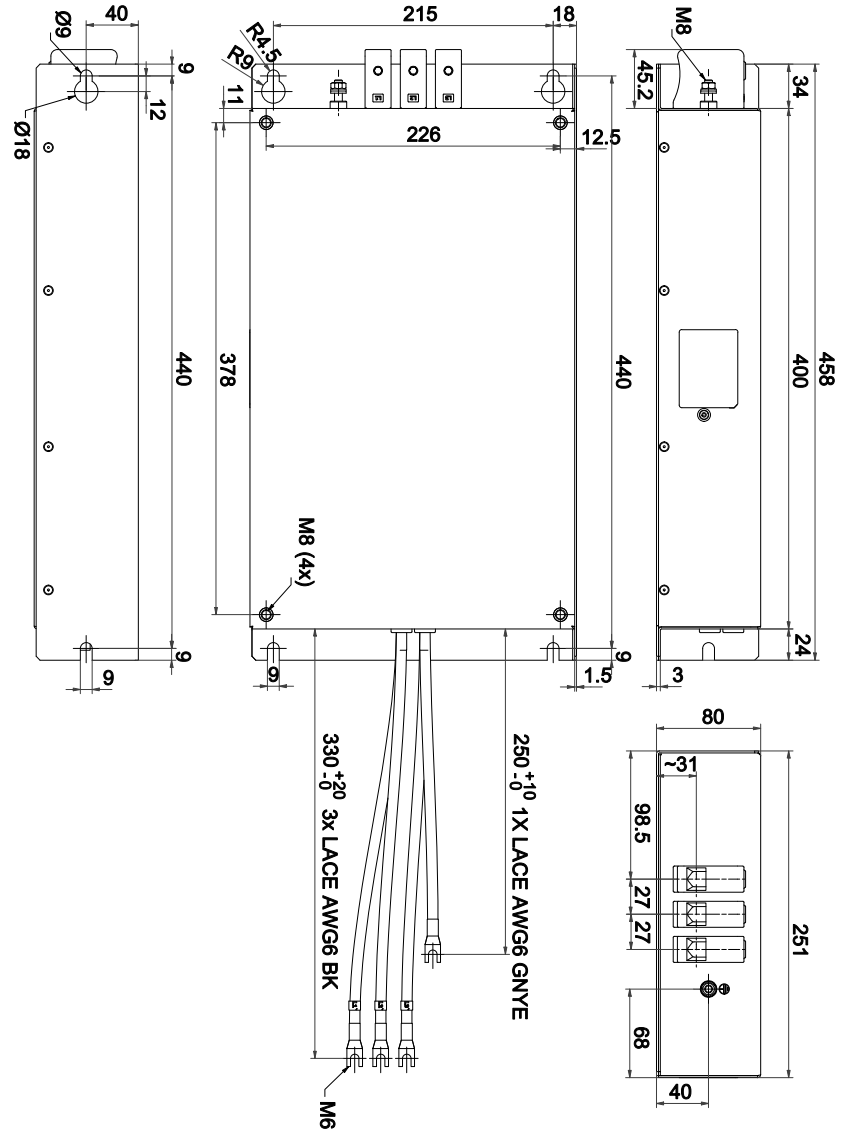

AX-FIC2008-SE

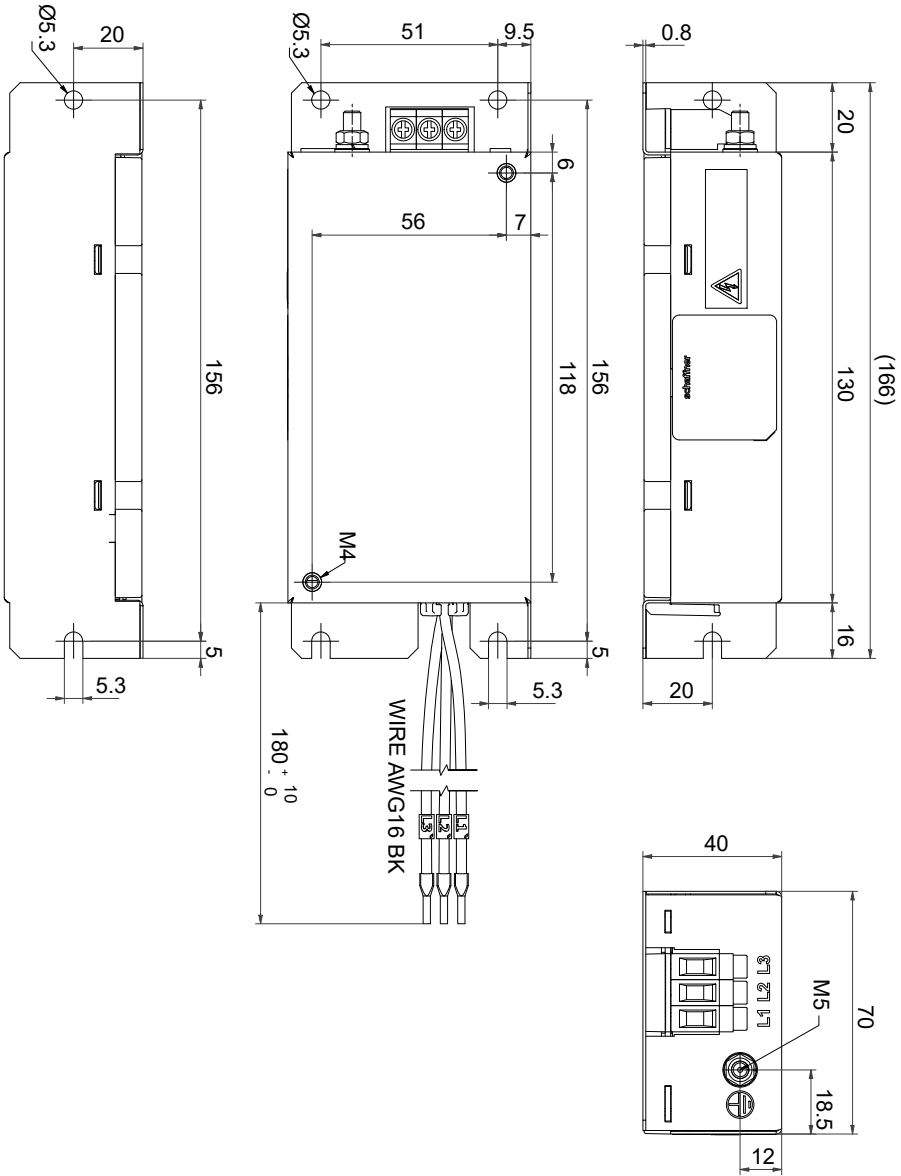

AX-FIC2018-SE

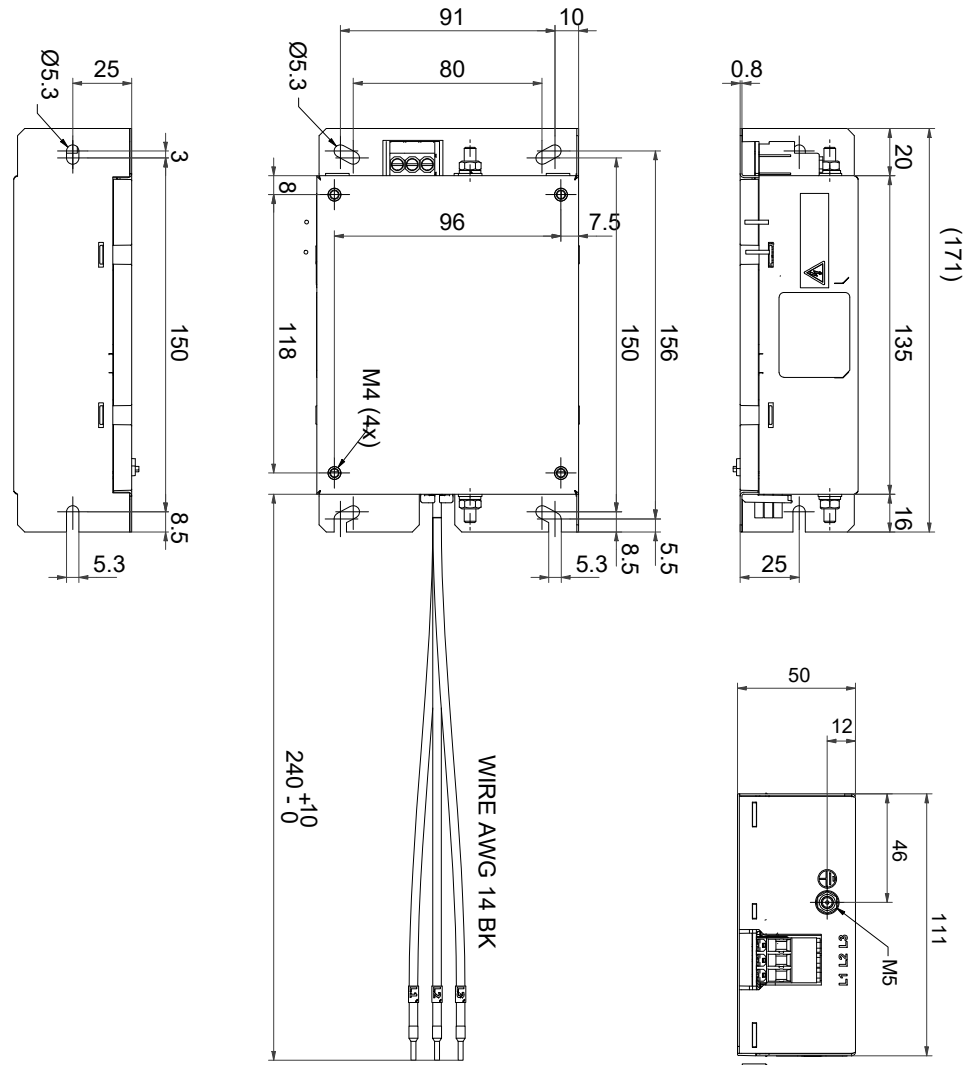

AX-FIC2029-SE

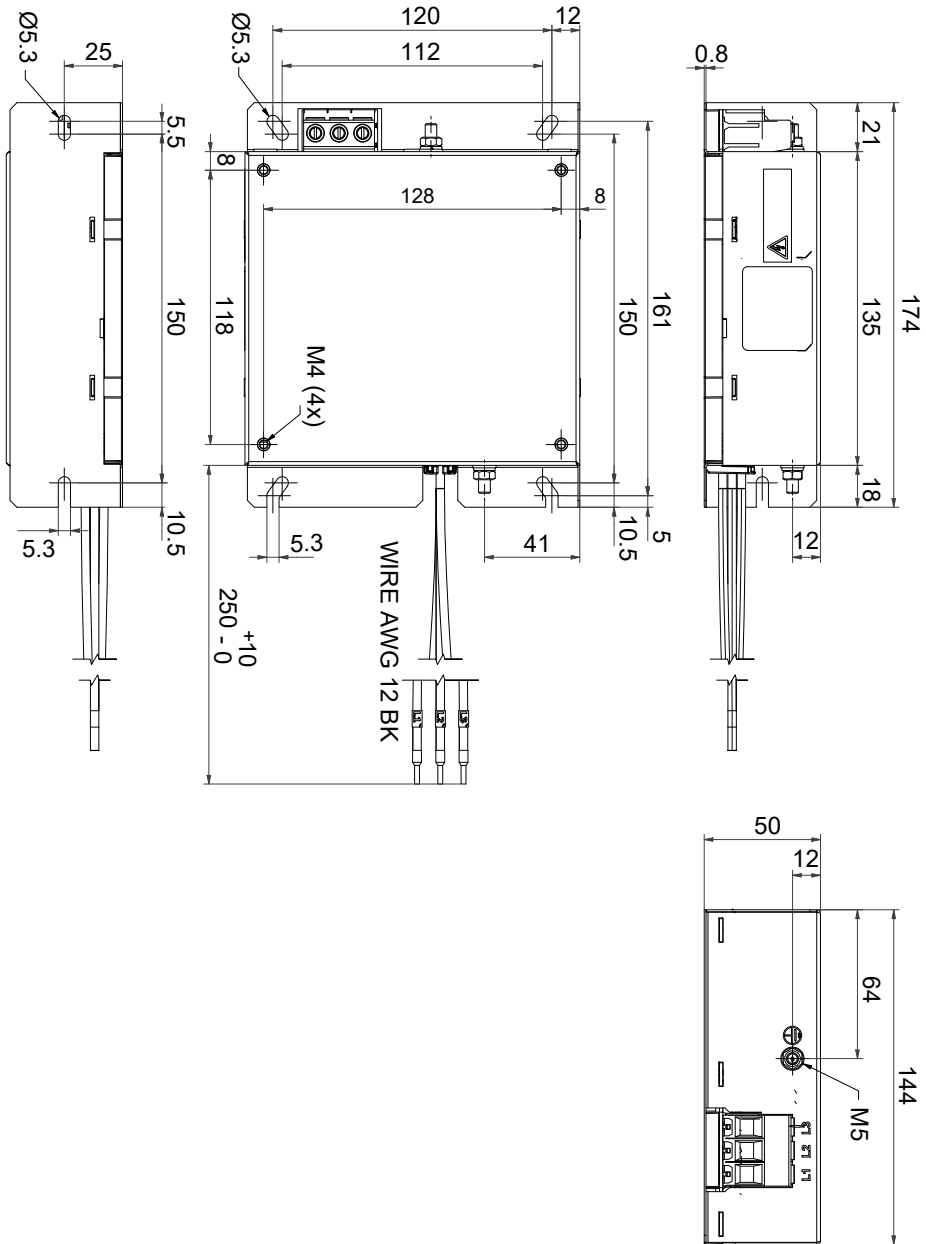

AX-FIC2061-SE

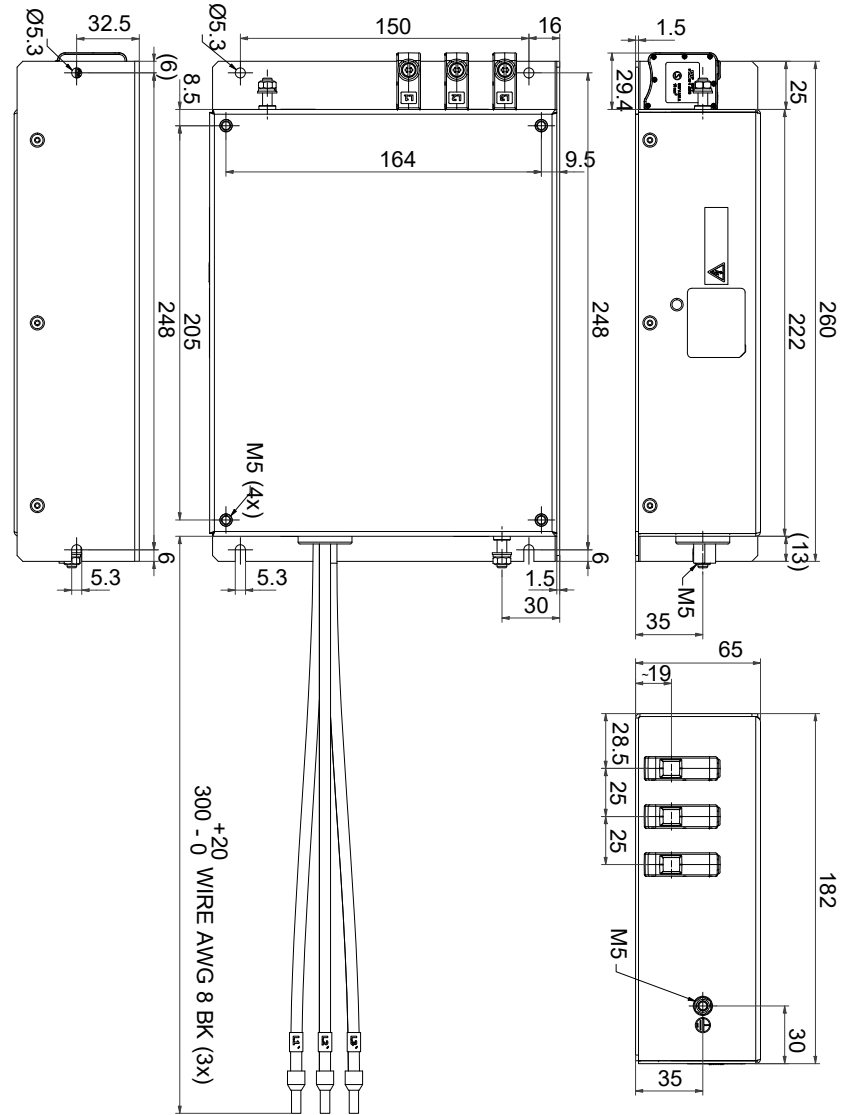

AX-FIC2097-SE

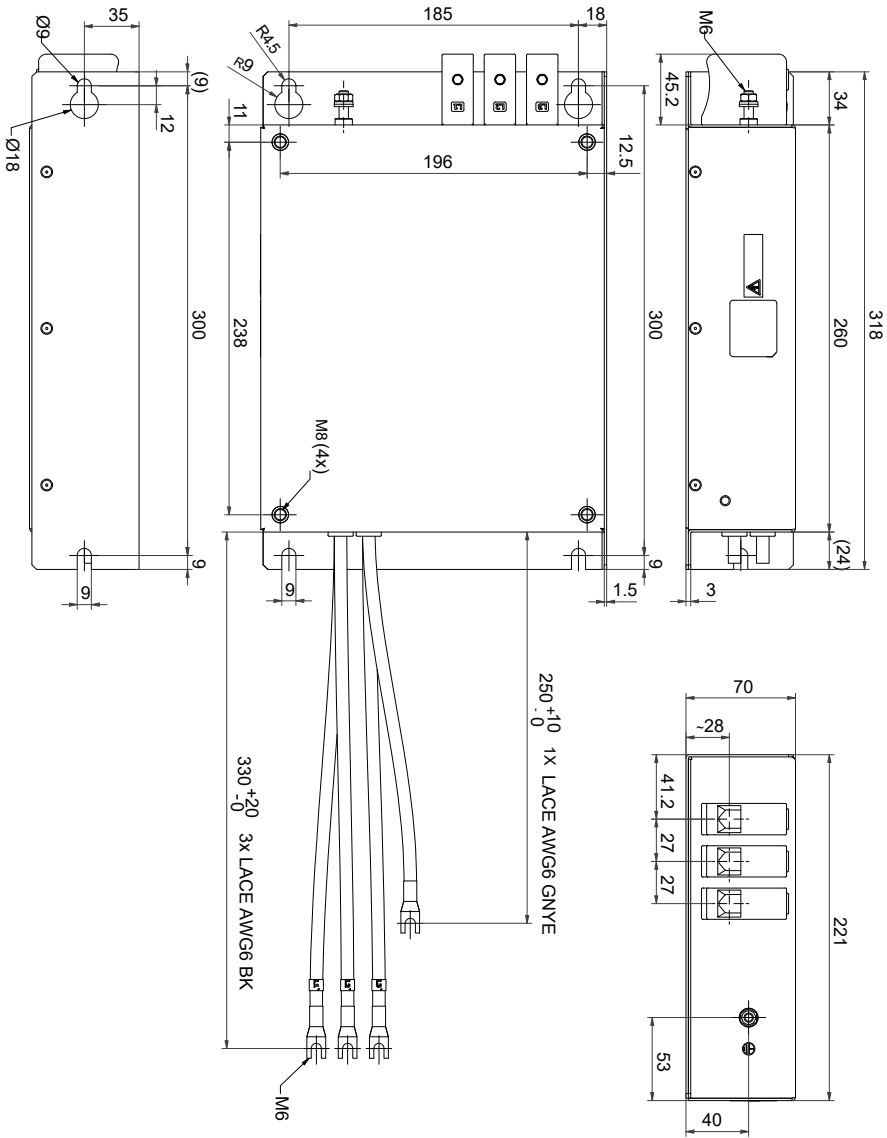

AX-FIC2112-SE

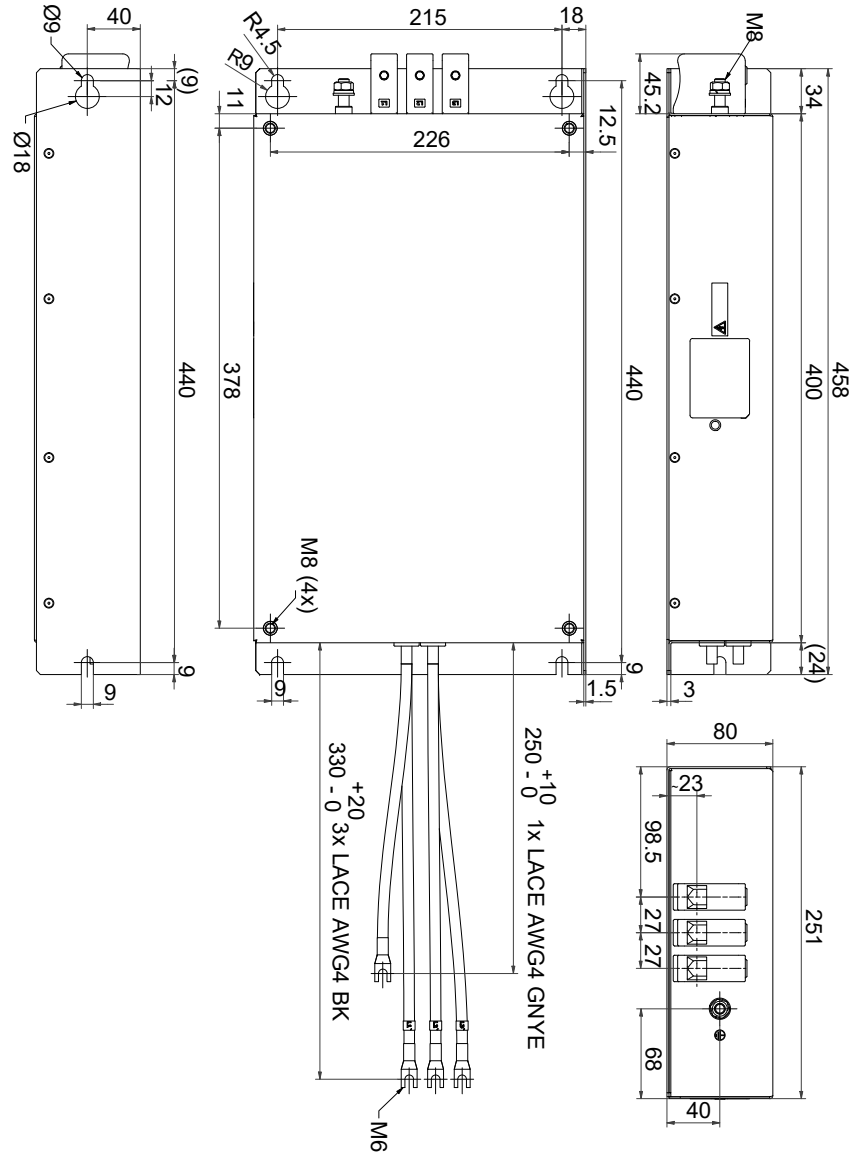

Input AC Reactor

Voltage	Reference	Fig	Dimensions										Weight (kg)																																																																																																	
			A	B	B2	C	C2	D	E	F	G	H																																																																																																		
Single-phase 200 V	AX-RAI02000070-DE	1	84		-	96	-	101	66	5	7.5	2	1.22																																																																																																	
	116					1.95																																																																																																								
	131					2.55																																																																																																								
	116					1.95																																																																																																								
	AX-RAI00210330-DE	2	120	113	80	120	80	62	5.5	-	-	-	2.35																																																																																																	
AX-RAI02920030-DE	180				70								190	140	55	6	-	-	-	-	1.78																																																																																									
AX-RAI01570050-DE																						80	85	205	140	55	6	-	-	-	-	2.35																																																																														
AX-RAI00940080-DE																																	180	75	195	140	55	6	-	-	-	-	5.5																																																																			
AX-RAI00670110-DE																																												120	80	120	80	62	5.5	-	-	-	-	2.35																																																								
AX-RAI00450170-DE																																																							180	85	205	140	55	6	-	-	-	-	5.5																																													
AX-RAI00290250-DE																																																																		180	75	195	140	55	6	-	-	-	-	2.35																																		
AX-RAI00210330-DE																																																																													180	80	120	80	62	5.5	-	-	-	-	5.5																							
AX-RAI00180670-DE																																																																																								180	85	205	140	55	6	-	-	-	-	2.35												
AX-RAI00110600-DE																																																																																																			180	75	195	140	55	6	-	-	-	-	5.5	
AX-RAI00070870-DE																																																																																																														180
AX-RAI00091000-DE		180	85	205		140	55	6	-	-	-	-																																																																																																		
AX-RAI07700042-DE	180				105								205	140	75	6	-	-	-	-	11.2																																																																																									
AX-RAI03700040-DE																						180	85	190	140	55	6	-	-	-	-	1.78																																																																														
AX-RAI03700040-DE																																	180	75	195	140	55	6	-	-	-	-	5.5																																																																			
AX-RAI02800080-DE																																												180	80	120	80	62	5.5	-	-	-	-	2.35																																																								
AX-RAI01630090-DE																																																							180	85	205	140	55	6	-	-	-	-	5.5																																													
AX-RAI01300170-DE																																																																		180	75	195	140	55	6	-	-	-	-	2.35																																		
AX-RAI00810180-DE																																																																													180	80	120	80	62	5.5	-	-	-	-	5.5																							
AX-RAI00740335-DE																																																																																								180	85	205	140	55	6	-	-	-	-	2.35												
AX-RAI00440300-DE																																																																																																			180	75	195	140	55	6	-	-	-	-	5.5	
AX-RAI00300450-DE																																																																																																														180
AX-RAI00360500-DE		180	85	205		140	55	6	-	-	-	-																																																																																																		
AX-RAI00290780-DE	180				105								205	140	75	6	-	-	-	-	-																																																																																									

Figure 1

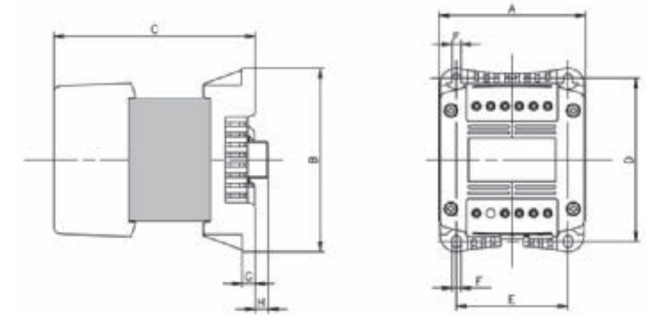
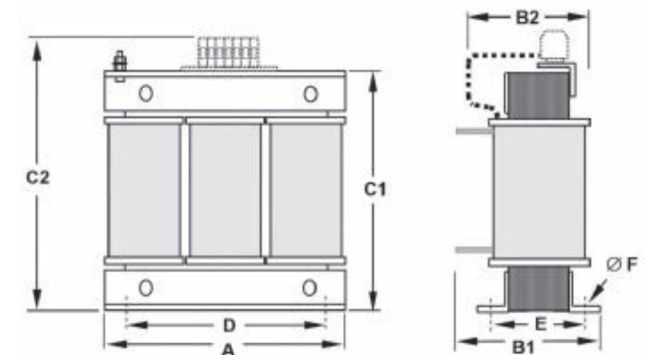

Figure 2



DC Reactor

Voltage	Reference	Fig	Dimensions (mm)								Weight (kg)	
			A	B	C	D	E	F	G	H		
200 V	AX-RC21400016-DE	1	84	113	96	101	66	5	7.5	2	1.22	
	AX-RC10700032-DE				105						1.60	
	AX-RC06750061-DE										1.95	
	AX-RC03510093-DE		108	135	124	120	82	6.5	9.5	9.5	3.20	
	AX-RC02510138-DE				116						5.20	
	AX-RC01600223-DE		120	152	136	135	94	7	9.5	9.5	6.00	
	AX-RC01110309-DE				146						11.40	
	AX-RC00840437-DE		150	177	160	160	115	7	2	-	-	14.30
	AX-RC00590614-DE				183							17.00
	AX-RC00440859-DE				195							161
AX-RC00301275-DE	2	195	161	163	185	88	10	-	-	14.30		
400 V	AX-RC43000020-DE	1	84	113	96	101	66	5	7.5	2	1.22	
	AX-RC27000030-DE				105						1.60	
	AX-RC14000047-DE										1.95	
	AX-RC10100069-DE		108	135	133	120	82	6.5	9.5	9.5	3.70	
	AX-RC06400116-DE				116						5.20	
	AX-RC04410167-DE		120	152	136	135	94	7	9.5	9.5	6.00	
	AX-RC03350219-DE				146						11.40	
	AX-RC02330307-DE		150	177	160	160	115	7	2	-	-	14.30
	AX-RC01750430-DE				183							17.00
	AX-RC01200644-DE		2	195	161	163	185	88	10	-	-	11.40
AX-RC00920797-DE	196	123			25.00							

Figure 1

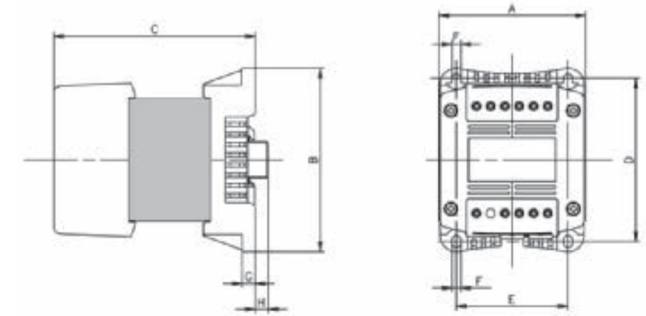
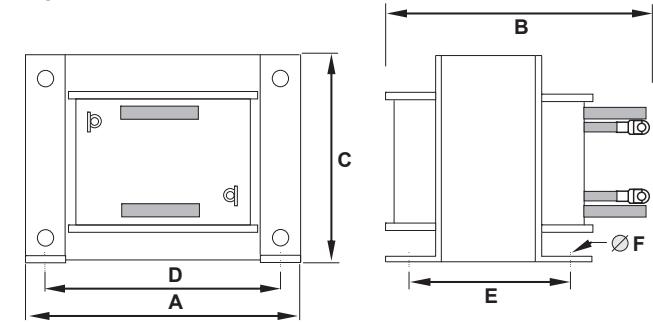
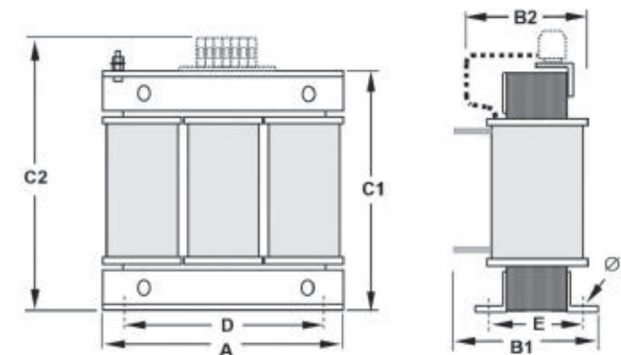

Figure 2



Voltage	Reference	Dimensions (mm)						Weight (kg)		
		A	B2	C2	D	E	F			
200 V	AX-RAO11500026-DE	120	70	120	80	52	5.5	1.78		
	AX-RAO07600042-DE		80			62			5.5	2.35
	AX-RAO04100075-DE					62				
	AX-RAO03000105-DE	180	85	195	140	55	6	5.5		
	AX-RAO01830160-DE			210		65		9.1		
	AX-RAO01150220-DE					65			9.1	
	AX-RAO00950320-DE		105	210	140	65	6	11.7		
	AX-RAO00630430-DE			210		65		11.7		
	AX-RAO00490640-DE		240	110	275	200	75	6	16.0	
	AX-RAO00390800-DE				275		75		16.0	
AX-RAO00330950-DE	275	75			16.0					
400 V	AX-RAO16300038-DE	120	80	120	80	62	5.5	2.35		
	AX-RAO11800053-DE								180	85
	AX-RAO07300080-DE	210	65	9.1						
	AX-RAO04600110-DE		210		65	9.1				
	AX-RAO03600160-DE	95	210	140	65	6	16.0			
	AX-RAO02500220-DE		210		65			16.0		
	AX-RAO02000320-DE	240	110	275	200	75	6	16.0		
	AX-RAO01650400-DE			275		75			16.0	
	AX-RAO01300480-DE			275		75			16.0	
AX-RAO00800750-DE	120	120	281	200	85	6	18.6			
AX-RAO00800750-DE			281		85			18.6		

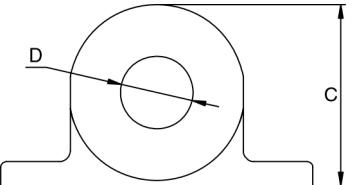
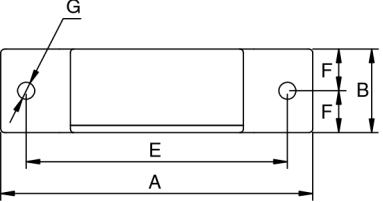
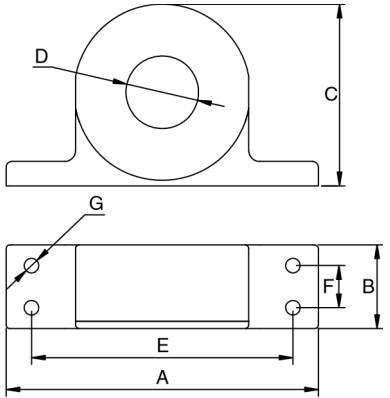

Chokes

Reference	D(diameter)	Motor (kW)	Dimensions (mm)							Weight	
			A	B	C	D	E	F	G (diameter)		
AX-FER2102-PE	21	<2.2	86	24	50	21	70	12	4	0.09	
AX-FER2815-PE	28	<15	106	25	65	28	90	12.5	4	0.22	
AX-FER5045-PE	50	<45	150	51	112	50	125	30	5	0.53	

Braking resistor

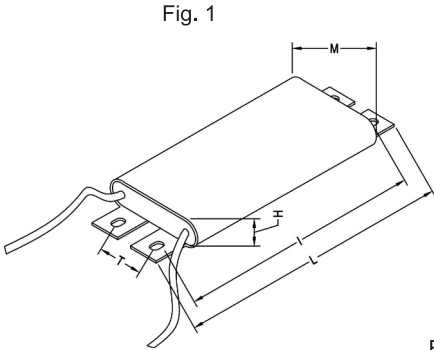

Fig. 1

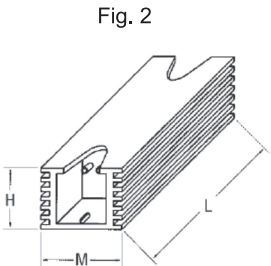

Fig. 2

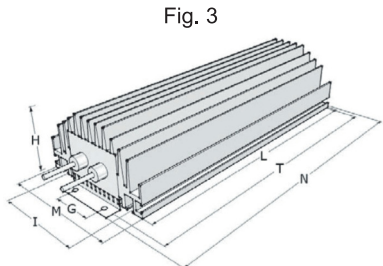

Fig. 3

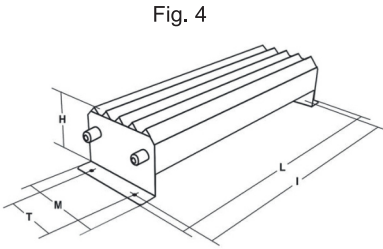

Fig. 4

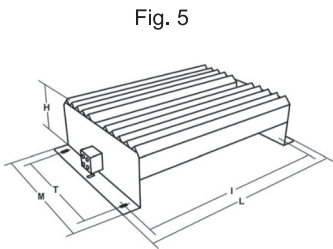
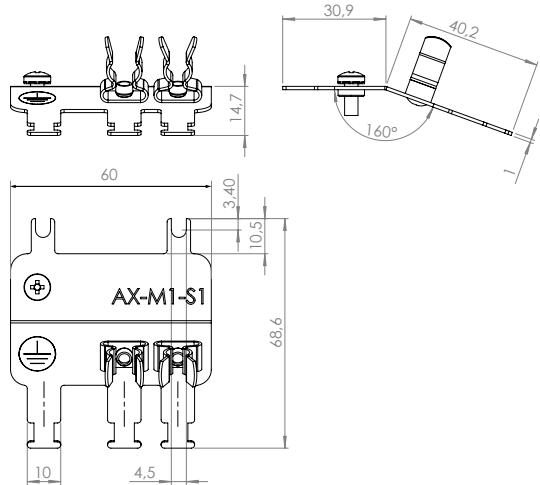

Fig. 5

Type	Fig	Dimensions (mm)						Weight (kg)	
		L	H	M	I	T	G		N
AX-REM00K1xxx-IE	1	182	13	45	168	20		0.27	
AX-REM00K2xxx-IE	2	105	27	36	94	-		0.17	
AX-REM00K3xxx-IE		155			144			0.26	
AX-REM00K4xxx-IE		200			189			0.425	
AX-REM00K6xxx-IE		320			309			0.73	
AX-REM00K9xxx-IE	3	200	61	100	74.5	216	40	230	1.41
AX-REM01K1xxx-IE		260				276		290	1.83
AX-REM01K2xxx-IE		320				336		350	2.25
AX-REM01K9xxx-IE	4	365	73	105	350	70	-		4
AX-REM02K1xxx-IE	5	310	115	230	295	170			7
AX-REM03K5xxx-IE		365			350				8

Shield clamps dimensions

AX-M1-S1



AX-M1-S2

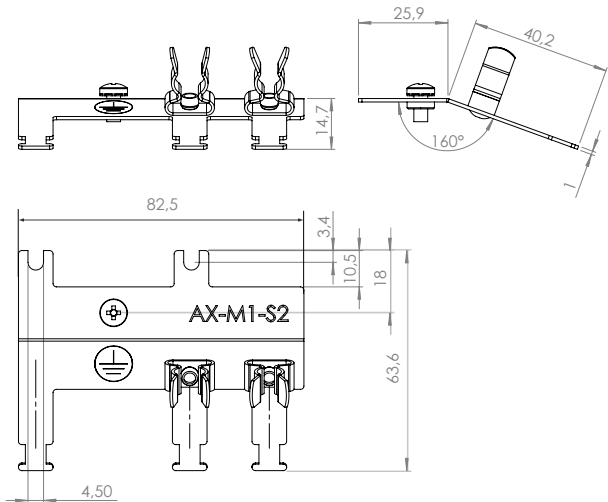

AX-M1-S3

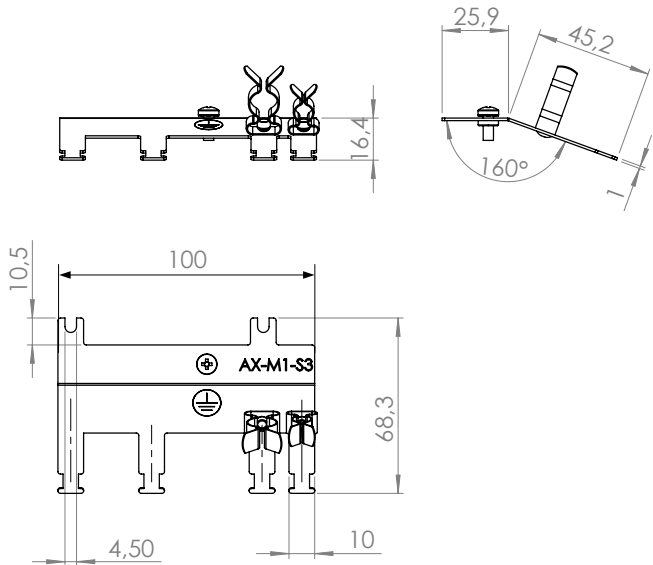

AX-M1-S4

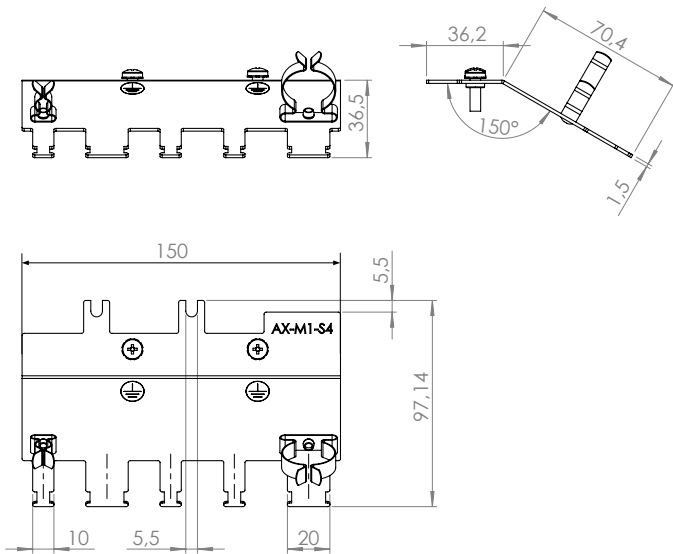

AX-M1-S5

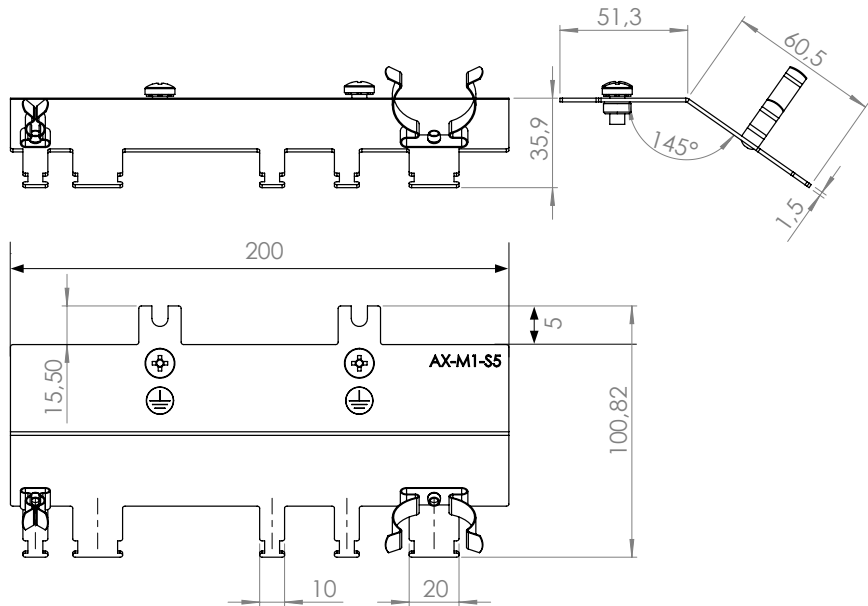

AX-M1-S6

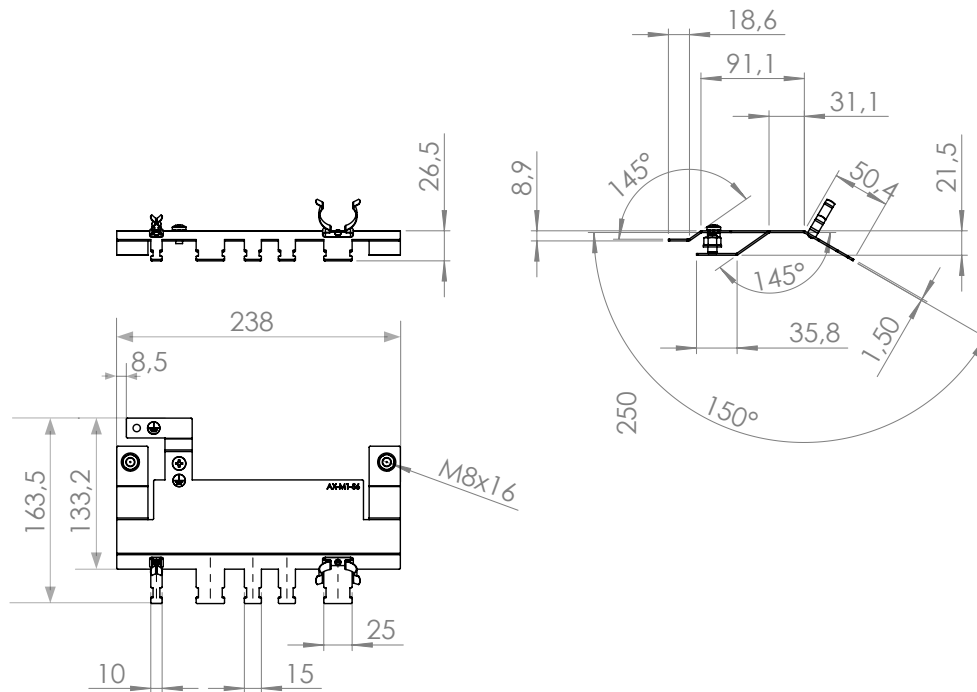

Installation

Standard connections

Main circuit

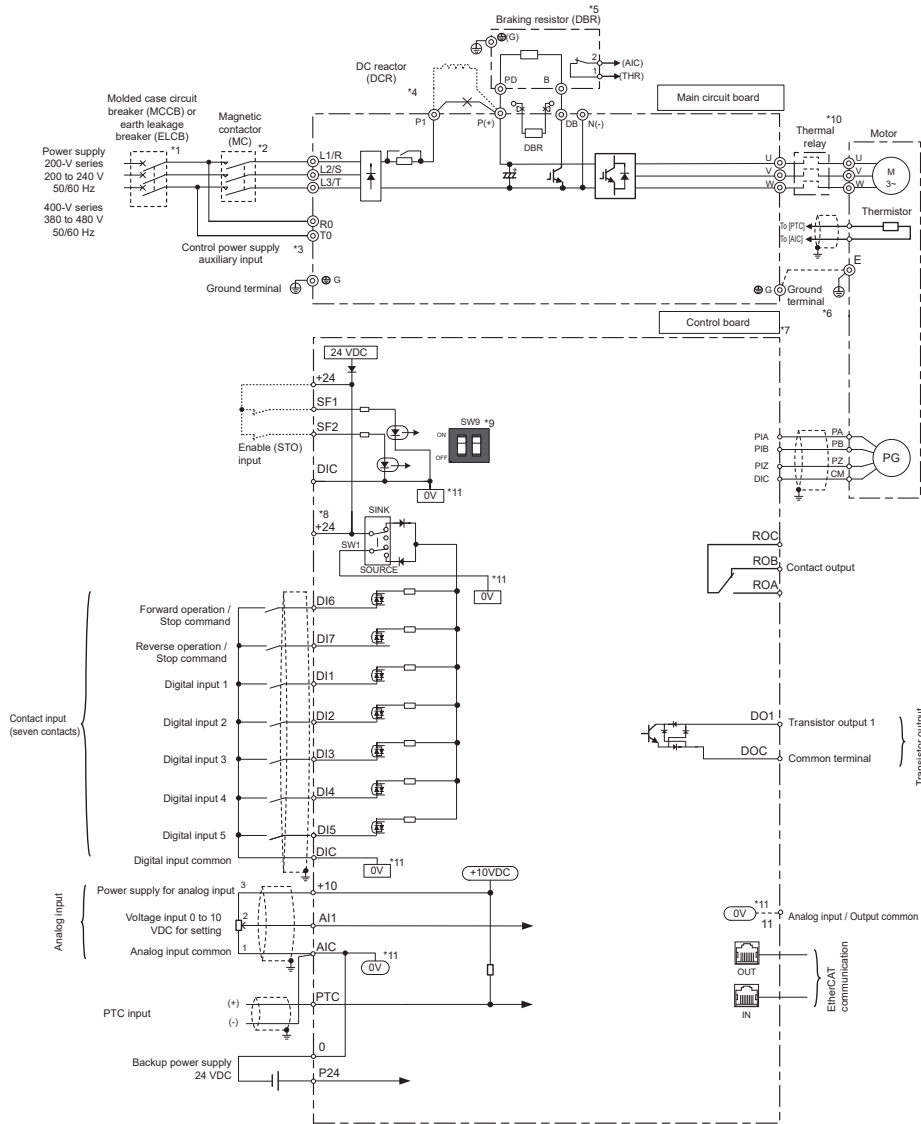

Terminal	Name	Function
L1/R, L2/S, L3/T	Main supply terminals (3G3M1-A2 and 3G3M1-A4)	Used to connect a power supply
L1/L, L2/N	Main circuit power supply input (3G3M1-AB_)	Used to connect a power supply
U, V, W	Inverter output terminal	Used to connect a motor
P(+), DB	Braking resistor connection	To connect a braking resistor
P1, P(+)	DC reactor connection Regenerative braking unit connection terminal	Remove the short-circuit to connect to the optimal DC reactor
P(+), N(-)		Connect optional regenerative braking unit if braking torque produced by internal braking transistor is not enough
R0, T0	Control power supply auxiliary input	Only available for inverter size of 18KW or more. Helps to keep control signal, digital operator or communications alive while main supply is OFF 3G3M1-A2185: 1-phase 200 to 240V 50/60Hz 3G3M1-A4185/220: 1-phase 220 to 480V, 50/60Hz
G	Ground terminal	Connect the terminal to ground

Control circuit

Type	Terminal	Name	Function (Signal level)
Digital input signals	DI1	Multi-Function Digital Input 1 (Multi-speed 1)	Voltage levels between input and the DIC: ON voltage: 20V min OFF voltage: 2V max Maximum 27 VDC Load current (DI1, DI2): 2.5 to 16mA (At 27V) Load current (DI3 to DI7): 2.5 to 5mA (at 27V) Impedance: 5.4 kΩ
	DI2	Multi-Function Digital Input 2 (Multi-speed 2)	
	DI3	Multi-Function Digital Input 3 (Multi-speed 3)	
	DI4	Multi-Function Digital Input 4 (Multi-speed 4)	
	DI5	Multi-Function Digital Input 5 (Free run stop)	
	DI6	Multi-Function Digital Input 6 (Forward)	
	DI7	Multi-Function Digital Input 7 (Reverse)	
	DIC	Input Signal common	
Safety digital inputs	SF1	Safe input 1	Voltage levels between input and the DIC ON voltage: 20V min OFF voltage: 2V max Maximum 27VDC Load current: 2.5 to 5mA (at 27V) Impedance: 6.6 kΩ
	SF2	Safe input 2	
Pulse	PIA	Pulse and encoder input	Voltage between input and DIC (5 to 24 VDC) ON voltage: 4 V min OFF voltage: 2 V max Maximum 27 VDC Frequency: 32 KHz
	PIB		Voltage between input and DIC (5 to 24 VDC) ON voltage: 4 V min OFF voltage: 2 V max Maximum 27 VDC Frequency: 32 KHz max Impedance: : 7.2 kΩ
	PIZ		Voltage between input and DIC (5 to 24 VDC) ON voltage: 4 V min OFF voltage: 2 V max Maximum 27 VDC Frequency: 32 KHz max Impedance: : 7.2 kΩ

Type	Terminal	Name	Function (signal level)
Analog input signals	+10	Power supply for analog input	Max. Current: 10 mA
	AI1	Analog voltage input	Allowable input voltage range: -15 to 10VDC Impedance: 22kΩ
	AIC	Analog input common	
	PTC	External thermistor input	Thermistor between the PTC and the AIC
Fault relay output	ROA	Relay output terminal NO	Relay output 250 VAC, 0.3 A 48 VDC, 0.5 A
	ROB	Relay output terminal NC	
	ROC	Relay output common	
Multi-function photocoupler output	DO1	Multi-Function Photocoupler Output 1 (During Run)	Open collector output across DO1-DOC Max Voltage 48 VDC and 50mA
	DOC	Output signal common	
Power supply	+24	Power supply terminal	Max 100 mA
	P24	Auxiliary power supply input for control circuit. P24 terminal is insulated from +24 terminal	24 VDC (22 to 26 V) and 500 mA max.
	0		

Side by side mounting

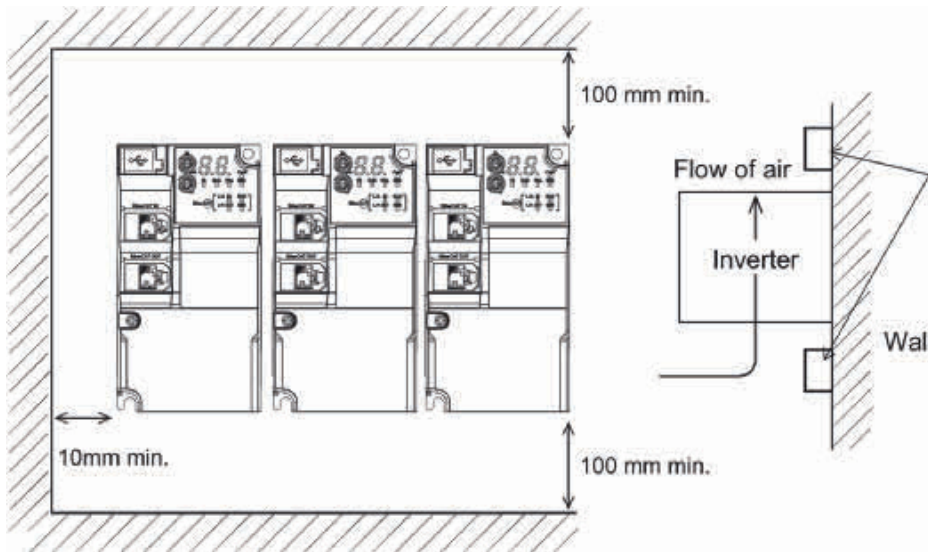

ADD 4 mm gap between drives (Side by side reduces by 10 °C ambient temperature specifications)

Drive watt loss

Max motor capacity	200 V			400 V		
	Loss at 0% load of rated current [W]	Loss at 100% load of the rated current [W]	Efficiency at 100% load [W]	Loss at 0% load of rated current [W]	Loss at 100% load of the rated current [W]	Efficiency at 100% load [W]
0.2	10	22	90	-	-	-
0.4	10	30	93	10	35	92
0.75	12 (10)*1	48	94	10	56	93
1.5	12	79	95	12	96	94
2.2	12	104	95.5	12	116	95
3.0	-	-	-	12	125	96
3.7	12	154	96	-	-	-
4.0	-	-	-	12	167	96
5.5	14	229	96	-	-	-
7.5	14	313	96	14	229	96
11	19	458	96	19	411	96.4
15	19	625	96	19	528	96.5

*1: The value in parentheses () I for single phase 200 V class inverter

Fuse size for Class CC, J or T types

Power supply voltage	Standard applicable motor (kW)	Inverter model	HND/HHD modes	Class CC, J or T fuse rating [Max. A] SCCR=100kA
Three phase 200 V	0.2	3G3M1-A2002	HHD	6A (600Vac)
	0.4	3G3M1-A2002	HND	6A (600Vac)
		3G3M1-A2004	HHD	10A (600Vac)
	0.75	3G3M1-A2004	HND	10A (600Vac)
		3G3M1-A2007	HHD	15A (600Vac)
	1.1	3G3M1-A2007	HND	15A (600Vac)
	1.5	3G3M1-A2015	HHD	20A (600Vac)
	2.2	3G3M1-A2015	HND	20A (600Vac)
		3G3M1-A2022	HHD	30A (600Vac)
	3	3G3M1-A2022	HND	30A (600Vac)
	3.7	3G3M1-A2037	HHD	40A (600Vac)
	5.5	3G3M1-A2037	HND	50A (600Vac)
		3G3M1-A2055	HHD	60A (600Vac)
	7.5	3G3M1-A2055	HND	80A (600Vac)
		3G3M1-A2075	HHD	80A (600Vac)
	11	3G3M1-A2075	HND	100A (600Vac)
		3G3M1-A2110	HHD	100A (600Vac)
	15	3G3M1-A2110	HND	150A (600Vac)
		3G3M1-A2150	HHD	150A (600Vac)
	18.5	3G3M1-A2150	HND	175A (600Vac)
3G3M1-A2185		HHD	175A (600Vac)	
22	3G3M1-A2185	HND	200A (600Vac)	

Power supply voltage	Standard applicable motor (kW)	Inverter model	HHD/HD HND/ND modes	Class CC, J or T fuse rating [Max. A] SCCR=100kA
Three phase 400 V	0.4	3G3M1-A4004	HHD	3A (600Vac)
	0.75	3G3M1-A4004	HD/HND	6A (600Vac)
		3G3M1-A4004	ND	6A (600Vac)
		3G3M1-A4007	HHD	6A (600Vac)
	1.1	3G3M1-A4007	HD/HND	10A (600Vac)
	1.5	3G3M1-A4007	ND	10A (600Vac)
		3G3M1-A4015	HHD	10A (600Vac)
	2.2	3G3M1-A4015	HD/HND	15A (600Vac)
		3G3M1-A4015	ND	15A (600Vac)
		3G3M1-A4022	HHD	20A (600Vac)
	3	3G3M1-A4022	HD/HND/ND	20A (600Vac)
		3G3M1-A4030	HHD	20A (600Vac)
	3.7	3G3M1-A4030	HD/HND/ND	30A (600Vac)
		3G3M1-A4040	HHD	30A (600Vac)
	5.5	3G3M1-A4040	HD/HND/ND	30A (600Vac)
		3G3M1-A4055	HHD	30A (600Vac)
	7.5	3G3M1-A4055	HD/HND	40A (600Vac)
		3G3M1-A4055	ND	60A (600Vac)
		3G3M1-A4075	HHD	60A (600Vac)
	11	3G3M1-A4075	HD/HND	60A (600Vac)
		3G3M1-A4075	ND	70A (600Vac)
		3G3M1-A4110	HHD	60A (600Vac)
	15	3G3M1-A4075	ND	70A (600Vac)
		3G3M1-A4110	HD/HND	70A (600Vac)
		3G3M1-A4150	HHD	90A (600Vac)
	18.5	3G3M1-A4110	ND	90A (600Vac)
		3G3M1-A4150	HD/HND	90A (600Vac)
		3G3M1-A4185	HHD	90A (600Vac)
	22	3G3M1-A4150	ND	100A (600Vac)
		3G3M1-A4185	HD/HND	100A (600Vac)
		3G3M1-A4220	HHD	100A (600Vac)
	30	3G3M1-A4185	ND	125A (600Vac)
		3G3M1-A4220	HD/HND	125A (600Vac)
	37	3G3M1-A4220	ND	175A (600Vac)

Size for Inverse Time Circuit Breaker type

Power supply voltage	Standard applicable motor (kW)	Inverter model	HND/HHD modes	Class CC, J or T fuse rating [Max. A] SCCR=100kA
Single phase 200V	0.2	3G3M1-AB002	HHD	6A (600Vac)
	0.4	3G3M1-AB002	HND	10A (600Vac)
		3G3M1-AB004	HHD	10A (600Vac)
	0.75	3G3M1-AB004	HND	15A (600Vac)
		3G3M1-AB007	HHD	20A (600Vac)
	1.1	3G3M1-AB007	HND	30A (600Vac)
	1.5	3G3M1-AB015	HHD	30A (600Vac)
	2.2	3G3M1-AB015	HND	40A (600Vac)
		3G3M1-AB022	HHD	50A (600Vac)
	3	3G3M1-AB022	HND	60A (600Vac)
3.7	3G3M1-AB037	HHD	80A (600Vac)	

Power supply voltage	Standard applicable motor (kW)	Inverter model	HHD/HD HND/ND modes	Inverse time circuit breaker rating (Max. A] SCCR=100kA
Three phase 200 V Vmin=240 Vac	0.2	3G3M1-A2002	HHD	15A
	0.4	3G3M1-A2002	HND	15A
		3G3M1-A2004	HHD	15A
	0.75	3G3M1-A2004	HND	15A
		3G3M1-A2007	HHD	15A
	1.1	3G3M1-A2007	HND	15A
	1.5	3G3M1-A2015	HHD	20A
	2.2	3G3M1-A2015	HND	20A
		3G3M1-A2022	HHD	30A
	3	3G3M1-A2022	HND	30A
	3.7	3G3M1-A2037	HHD	50A
	5.5	3G3M1-A2037	HND	50A
		3G3M1-A2055	HHD	80A
	7.5	3G3M1-A2055	HND	80A
		3G3M1-A2075	HHD	100A
	11	3G3M1-A2075	HND	100A
		3G3M1-A2110	HHD	125A
	15	3G3M1-A2110	HND	125A
		3G3M1-A2150	HHD	150A
	18.5	3G3M1-A2150	HND	150A
3G3M1-A2185		HHD	175A	
22	3G3M1-A2185	HND	175A	

Power supply voltage	Standard applicable motor (kW)	Inverter model	HND/HHD modes	Inverse time circuit breaker rating [Max. A] SCCR=100kA
Three phase 400 V Vmin=480 Vac	0.4	3G3M1-A4004	HHD	15A
	0.75	3G3M1-A4004	HD/HND	15A
		3G3M1-A4004	ND	15A
		3G3M1-A4007	HHD	15A
		3G3M1-A4007	HD/HND	15A
	1.5	3G3M1-A4007	ND	15A
		3G3M1-A4015	HHD	15A
	2.2	3G3M1-A4015	HD/HND	15A
		3G3M1-A4015	ND	15A
		3G3M1-A4022	HHD	20A
	3	3G3M1-A4022	HD/HND/ND	20A
		3G3M1-A4030	HHD	30A
	3.7	3G3M1-A4030	HD/HND/ND	30A
		3G3M1-A4040	HHD	30A
	5.5	3G3M1-A4040	HD/HND/ND	30A
		3G3M1-A4055	HHD	50A
	7.5	3G3M1-A4055	HD/HND	50A
		3G3M1-A4055	ND	50A
		3G3M1-A4075	HHD	70A
	11	3G3M1-A4075	HD/HND	70A
		3G3M1-A4075	ND	70A
		3G3M1-A4110	HHD	80A
	15	3G3M1-A4075	ND	70A
		3G3M1-A4110	HD/HND	80A
		3G3M1-A4150	HHD	100A
	18.5	3G3M1-A4110	ND	80A
		3G3M1-A4150	HD/HND	100A
		3G3M1-A4185	HHD	125A
22	3G3M1-A4150	ND	100A	
	3G3M1-A4185	HD/HND	125A	
	3G3M1-A4220	HHD	150A	
30	3G3M1-A4185	ND	125A	
	3G3M1-A4220	HD/HND	150A	
37	3G3M1-A4220	ND	150A	

Power supply voltage	Standard applicable motor (kW)	Inverter model	HHD/HD HND/ND modes	Inverse time circuit breaker rating (Max. A) SCCR=100kA
Single phase 200 V Vmin=240 Vac	0.2	3G3M1-AB002	HHD	15A
	0.4	3G3M1-AB002	HND	15A
		3G3M1-AB004	HHD	15A
	0.75	3G3M1-AB004	HND	15A
		3G3M1-AB007	HHD	30A
	1.1	3G3M1-AB007	HND	30A
	1.5	3G3M1-AB015	HHD	40A
		3G3M1-AB015	HND	40A
	2.2	3G3M1-AB015	HND	40A
		3G3M1-AB022	HHD	40A
	3	3G3M1-AB022	HND	40A
	3.7	3G3M1-AB037	HHD	70A

Ordering information

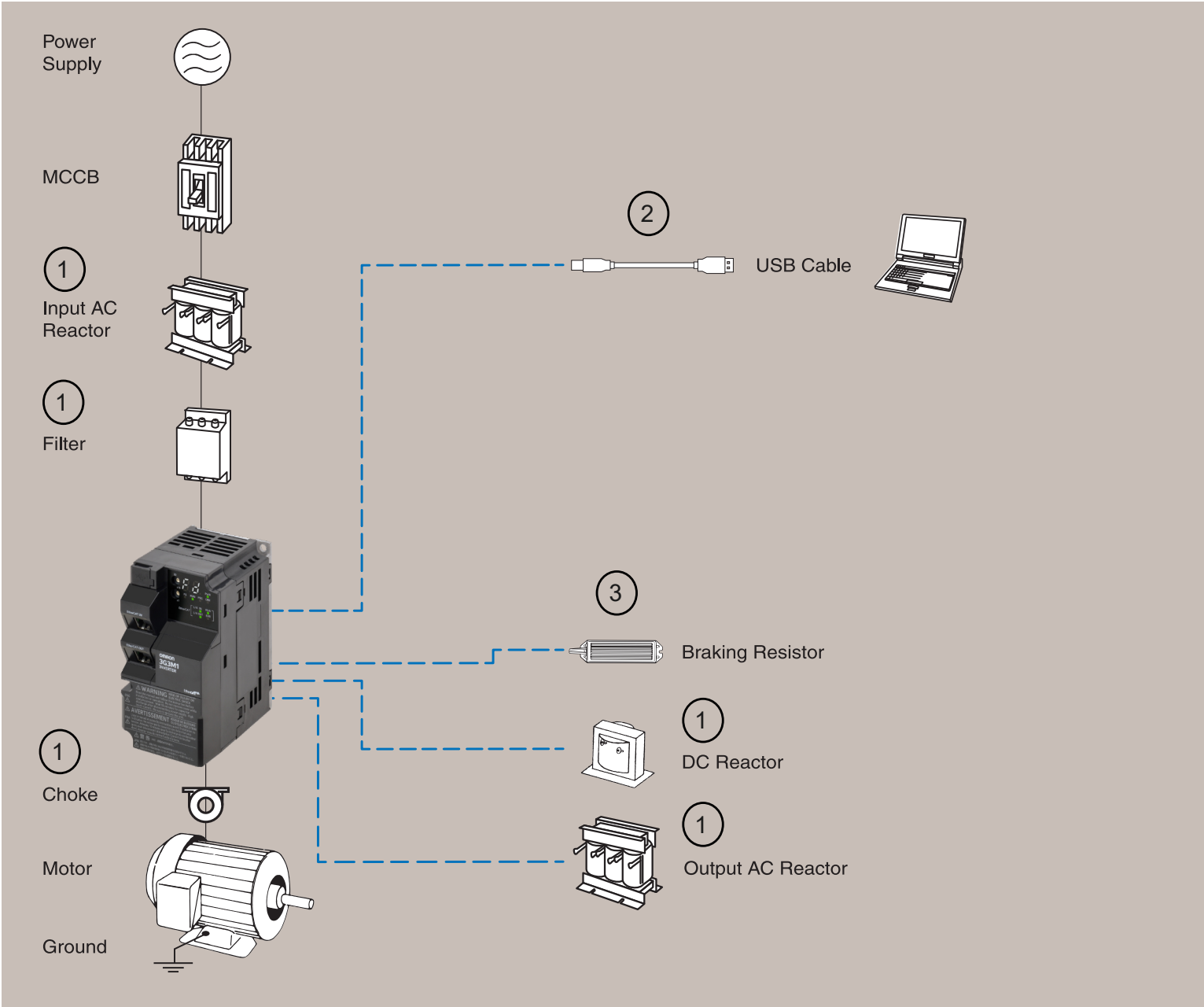

Drive

Voltage	Specifications								Model
	ND		HD		HND		HHD		
	Max motor (kW)	Rated current (A)	Max motor (kW)	Rated current (A)	Max motor (kW)	Rated current (A)	Max motor (kW)	Rated current (A)	
Single phase 200 V					0.4	1.9	0.2	1.6	3G3M1-AB002-ECT
					0.55	3.5	0.4	3.0	3G3M1-AB004-ECT
					1.1	5.3	0.75	5.0	3G3M1-AB007-ECT
					2.2	9.6	1.5	8.0	3G3M1-AB015-ECT
					3.0	11.2	2.2	11.0	3G3M1-AB022-ECT
					-	-	3.7	17.5	3G3M1-AB037-ECT
Three phase 200 V					0.4	2.0	0.2	1.6	3G3M1-A2002-ECT
					0.75	3.5	0.4	3.0	3G3M1-A2004-ECT
					1.1	6.0	0.75	5.0	3G3M1-A2007-ECT
					2.2	9.6	1.5	8.0	3G3M1-A2015-ECT
					3.0	12	2.2	11.0	3G3M1-A2022-ECT
					5.5	19.6	3.7	17.5	3G3M1-A2037-ECT
					7.5	30	5.5	25.0	3G3M1-A2055-ECT
					11.0	40	7.5	33	3G3M1-A2075-ECT
					15.0	56	11.0	47	3G3M1-A2110-ECT
					18.5	69	15.0	60	3G3M1-A2150-ECT
Three phase 400 V					22.0	88	18.5	76	3G3M1-A2185-ECT
					0.75	2.1	0.4	1.8	3G3M1-A4004-ECT
					1.5	4.1	0.75	3.4	3G3M1-A4007-ECT
					2.2	5.5	1.5	4.8	3G3M1-A4015-ECT
					3.0	6.9	2.2	5.5	3G3M1-A4022-ECT
					4.0	9.2	3.0	7.2	3G3M1-A4030-ECT
					5.5	12.0	4.0	9.2	3G3M1-A4040-ECT
					11.0	21.5	5.5	14.8	3G3M1-A4055-ECT
					15.0	28.5	7.5	18.0	3G3M1-A4075-ECT
					18.5	37.0	11.0	24.0	3G3M1-A4110-ECT
					22.0	44.0	15.0	31.0	3G3M1-A4150-ECT
					30.0	59.0	18.5	39.0	3G3M1-A4185-ECT
37.0	72.0	22.0	45.0	3G3M1-A4220-ECT					

1 Line filters

Drive		Standard line filter		Low leakage line filter	
Voltage	Model 3G3M1-A□-ECT	Reference	Current (A)	Reference	Current (A)
Single-phase 200 V	B002 to B007	AX-FIC1014-SE	13.8	AX-FIC1014-SE-LL	13.8
	B015	AX-FIC1021-SE	20.2	AX-FIC1021-SE-LL	20.2
	B022	AX-FIC1026-SE	26	AX-FIC1026-SE-LL	26
	B037	AX-FIC1045-SE	45.4	AX-FIC1045-SE-LL	45.4
Three-phase 200 V	2002/2004/2007	AX-FIC2008-SE	6.7*	-	
	2015/2022	AX-FIC2018-SE	17.9*		
	2037	AX-FIC2029-SE	28.5*		
	2055/2075	AX-FIC2061-SE	60.7*		
	2110/2150	AX-FIC2097-SE	97*		
	2185	AX-FIC2112-SE	112*		
Three-phase 400 V	4004/4007	AX-FIC4004-SE	4.8*	AX-FIC4004-SE-LL	4.8*
	4015/4022	AX-FIC4011-SE	11.3*	AX-FIC4011-SE-LL	11.3*
	4030/4040	AX-FIC4017-SE	16.8*	AX-FIC4017-SE-LL	16.8*
	4055/4075	AX-FIC4044-SE	43.8*	AX-FIC4044-SE-LL	43.8*
	4110/4150	AX-FIC4061-SE	60.6*	AX-FIC4061-SE-LL	60.6*
	4185/4220	AX-FIC4095-SE	94.3*	AX-FIC4095-SE-LL	94.3*

Note: Smaller filter could be used in some cases if DC reactor is used.

* Values for 40°C ambient temperature

1 DC reactors

400 V Three phase						200 V Single phase					
3G3M1-A□-ECT	Rating	Reference	mH	A	Losses W	3G3M1-A□-ECT	Rating	Reference	mH	A	Losses W
4004	HHD	AX-RC43000020-DE	43.0	2.0	17	B002	HHD	AX-RC10700032-DE	10.7	3.2	14
	HD/HND	AX-RC27000030-DE	27.0	3.0	21		HND	AX-RC06750061-DE	6.75	6.1	18
	ND	AX-RC27000030-DE	27.0	3.0	21	B004	HHD	AX-RC06750061-DE	6.75	6.1	18
4007	HHD	AX-RC27000030-DE	27.0	3.0	21	B007	HND	AX-RC03510093-DE	3.51	9.3	20
	HD/HND	AX-RC14000047-DE	14.0	4.7	25		HHD	AX-RC03510093-DE	3.51	9.3	20
	ND	AX-RC14000047-DE	14.0	4.7	25	HND	AX-RC02510138-DE	2.51	13.8	24	
4015	HHD	AX-RC14000047-DE	14.0	4.7	25	B015	HHD	AX-RC02510138-DE	2.51	13.8	24
	HD/HND	AX-RC10100069-DE	10.1	6.9	28		HND	AX-RC01600223-DE	1.60	22.3	30
	ND	AX-RC10100069-DE	10.1	6.9	28	B022	HHD	AX-RC01600223-DE	1.60	22.3	30
4022	HHD	AX-RC10100069-DE	10.1	6.9	32	B037	HND	AX-RC01110309-DE	1.11	30.9	40
	HD/HND	AX-RC06400116-DE	6.4	11.6	32		HHD	AX-RC01110309-DE	1.11	30.9	40
	ND	AX-RC06400116-DE	6.4	11.6	32	HND	-				
4030	HHD	AX-RC06400116-DE	6.4	11.6	32	200 V Three phase					
	HD/HND	AX-RC06400116-DE	6.4	11.6	32	2002	HHD	AX-RC21400016-DE	21.4	1.6	7
	ND	AX-RC06400116-DE	6.4	11.6	32		HND	AX-RC10700032-DE	10.7	3.2	14
4040	HHD	AX-RC06400116-DE	6.4	11.6	32	2004	HHD	AX-RC10700032-DE	10.7	3.2	14
	HD/HND	AX-RC04410167-DE	4.4	16.7	40		HND	AX-RC06750061-DE	6.75	6.1	18
	ND	AX-RC04410167-DE	4.4	16.7	40	2007	HHD	AX-RC06750061-DE	6.75	6.1	18
4055	HHD	AX-RC04410167-DE	4.4	16.7	40	2015	HND	AX-RC03510093-DE	3.51	9.3	20
	HD/HND	AX-RC03350219-DE	3.35	21.9	47		HHD	AX-RC03510093-DE	3.51	9.3	20
	ND	AX-RC02330307-DE	2.33	30.7	63	HND	AX-RC02510138-DE	2.51	13.8	24	
4075	HHD	AX-RC03350219-DE	3.35	21.9	47	2022	HHD	AX-RC02510138-DE	2.51	13.8	24
	HD/HND	AX-RC02330307-DE	2.33	30.7	63		HND	AX-RC01600223-DE	1.60	22.3	30
	ND	AX-RC01750430-DE	1.75	43.0	77	2037	HHD	AX-RC01600223-DE	1.60	22.3	30
4110	HHD	AX-RC02330307-DE	2.33	30.7	63	2055	HND	AX-RC01110309-DE	1.11	30.9	40
	HD/HND	AX-RC01750430-DE	1.75	43.0	77		HHD	AX-RC01110309-DE	1.11	30.9	40
	ND	AX-RC01750430-DE	1.75	43.0	77	HND	AX-RC00840437-DE	0.84	43.7	46	
4150	HHD	AX-RC01750430-DE	1.75	43.0	77	2075	HHD	AX-RC00840437-DE	0.84	43.7	46
	HD/HND	AX-RC01750430-DE	1.75	43.0	77		HND	AX-RC00590614-DE	0.59	61.4	60
	ND	AX-RC01200644-DE	1.20	64.4	99	2110	HHD	AX-RC00590614-DE	0.59	61.4	60
4185	HHD	AX-RC01750430-DE	1.75	43.0	77	2150	HND	AX-RC00440859-DE	0.44	85.9	75
	HD/HND	AX-RC01200644-DE	1.20	64.4	99		HHD	AX-RC00440859-DE	0.44	85.9	75
	ND	AX-RC00920797-DE	0.92	79.7	111	HND	AX-RC00440859-DE	0.44	85.9	75	
4220	HHD	AX-RC01200644-DE	1.20	64.4	99	2185	HHD	AX-RC00440859-DE	0.44	85.9	75
	HD/HND	AX-RC00920797-DE	0.92	79.7	111		HND	AX-RC00301275-DE	0.3	127.5	107

1 Input AC reactor (Considering DC reactor is installed)

400 V Three phase						200 V Single phase					
3G3M1-A□-ECT	Rating	Reference	mH	A	Losses (w)	3G3M1-A□-ECT	Rating	Reference	mH	A	Losses (W)
4004	HHD	AX-RAI07700042-DE	7.7	4.2	32	B002	HHD	AX-RAI02000070-DE	2.0	7.0	14
	HD/HND	AX-RAI07700042-DE	7.7	4.2	32		HND	AX-RAI02000070-DE	2.0	7.0	14
	ND	AX-RAI07700042-DE	7.7	4.2	32		B004	HHD	AX-RAI02000070-DE	2.0	7.0
4007	HHD	AX-RAI03700040-DE	3.7	4.0	18	HND		AX-RAI02000070-DE	2.0	7.0	14
	HD/HND	AX-RAI03700040-DE	3.7	4.0	18	B007	HHD	AX-RAI01700140-DE	1.7	14.0	22
	ND	AX-RAI03700040-DE	3.7	4.0	18		HND	AX-RAI01700140-DE	1.7	14.0	22
4015	HHD	AX-RAI02800080-DE	2.8	8.0	31	B015	HHD	AX-RAI01700140-DE	1.7	14.0	22
	HD/HND	AX-RAI02800080-DE	2.8	8.0	31		HND	AX-RAI01200200-DE	1.2	20.0	24
	ND	AX-RAI02800080-DE	2.8	8.0	31	B022	HHD	AX-RAI01200200-DE	1.2	20.0	24
4022	HHD	AX-RAI01630090-DE	1.63	9.0	40		B037	HND	AX-RAI00210330-DE*	0.21	33.0
	HD/HND	AX-RAI01630090-DE	1.63	9.0	40	HHD		AX-RAI00210330-DE*	0.21	33.0	69
	ND	AX-RAI01630090-DE	1.63	9.0	40	200 V Three phase					
4030	HHD	AX-RAI01630090-DE	1.63	9.0	40						
	HD/HND	AX-RAI01630090-DE	1.63	9.0	40						
	ND	AX-RAI01630090-DE	1.63	9.0	40						
4040	HHD	AX-RAI01300170-DE	1.30	17.0	67	2002	HHD	AX-RAI02920030-DE	2.92	3.0	8
	HD/HND	AX-RAI01300170-DE	1.30	17.0	67		HND	AX-RAI02920030-DE	2.92	3.0	8
	ND	AX-RAI01300170-DE	1.30	17.0	67	2004	HHD	AX-RAI01570050-DE	1.57	5.0	12
4055	HHD	AX-RAI00810180-DE	0.81	18.0	79		HND	AX-RAI01570050-DE	1.57	5.0	12
	HD/HND	AX-RAI00810180-DE	0.81	18.0	79	2007	HHD	AX-RAI01570050-DE	1.57	5.0	12
	ND	AX-RAI00740335-DE	0.74	33.5	79		HND	AX-RAI00940080-DE	0.94	8.0	18
4075	HHD	AX-RAI00810180-DE	0.81	18.0	79	2015	HHD	AX-RAI00940080-DE	0.94	8.0	18
	HD/HND	AX-RAI00740335-DE	0.74	33.5	240		HND	AX-RAI00670110-DE	0.67	11.0	24
	ND	AX-RAI00440300-DE	0.44	30.0	119	2022	HHD	AX-RAI00670110-DE	0.67	11.0	24
4110	HHD	AX-RAI00740335-DE	0.74	33.5	240		HND	AX-RAI00450170-DE	0.45	17.0	39
	HD/HND	AX-RAI00440300-DE	0.44	30.0	119	2037	HHD	AX-RAI00450170-DE	0.45	17.0	39
	ND	AX-RAI00360500-DE	0.36	50.0	85		HND	AX-RAI00290250-DE	0.29	25.0	54
4150	HHD	AX-RAI00440300-DE	0.44	30.0	119	2055	HHD	AX-RAI00290250-DE	0.29	25.0	54
	HD/HND	AX-RAI00360500-DE	0.36	50.0	85		HND	AX-RAI00210330-DE	0.21	33.0	69
	ND	AX-RAI00300450-DE	0.30	45.0	182	2075	HHD	AX-RAI00210330-DE	0.21	33.0	69
4185	HHD	AX-RAI00360500-DE	0.36	50.0	85		HND	AX-RAI00180670-DE	0.18	67.0	71
	HD/HND	AX-RAI00300450-DE	0.30	45.0	182	2110	HHD	AX-RAI00180670-DE	0.18	67.0	71
	ND	AX-RAI00191150-DE	0.19	115.0	177		HND	AX-RAI00110600-DE	0.11	60.0	119
4220	HHD	AX-RAI00290780-DE	0.29	78.0	116	2150	HHD	AX-RAI00110600-DE	0.11	60.0	119
	HD/HND	AX-RAI00191150-DE	0.19	115.0	177		HND	AX-RAI00091000-DE	0.09	100.0	84
	ND	AX-RAI00191150-DE	0.19	115.0	177	2185	HHD	AX-RAI00091000-DE	0.09	100.0	84
					HND		AX-RAI00091000-DE	0.09	100.0	84	

Note: This table considers that DC reactor is installed on the drive and corresponds with ND/HND rating. When using HD in some case it could be possible to select a smaller size.

* This is a 3 phase reactor where only two of the phases are used.

1 Output AC reactors

200 V					Three-phase 400 V				
3G3M1-A□-ECT	Rating	Output AC reactor	mH	A	3G3M1-A□-ECT	Rating	Output AC reactor	mH	A
B002/2002	HHD	AX-RAO11500026-DE	11.5	2.6	4004	HHD	AX-RAO16300038-DE	16.3	3.8
	HND	AX-RAO11500026-DE	11.5	2.6		HD/HND	AX-RAO16300038-DE	16.3	3.8
B004/2004	HHD	AX-RAO07600042-DE	7.6	4.2	4007	ND	AX-RAO16300038-DE	16.3	3.8
	HND	AX-RAO07600042-DE	7.6	4.2		HHD	AX-RAO16300038-DE	16.3	3.8
B007/2007	HHD	AX-RAO04100075-DE	4.1	7.5	4015	HD/HND	AX-RAO11800053-DE	11.8	5.3
	HND	AX-RAO04100075-DE	4.1	7.5		ND	AX-RAO11800053-DE	11.8	5.3
B015/2015	HHD	AX-RAO03000105-DE	3.0	10.5	4022	HHD	AX-RAO11800053-DE	11.8	5.3
	HND	AX-RAO03000105-DE	3.0	10.5		HD/HND	AX-RAO07300080-DE	7.3	8.0
B0222	HHD	AX-RAO01830160-DE	1.8	16.0	4030	ND	AX-RAO07300080-DE	7.3	8.0
	HND	AX-RAO01830160-DE	1.8	16.0		HHD	AX-RAO07300080-DE	7.3	8.0
B037/2037	HHD	AX-RAO01150220-DE	1.15	22.0	4040	HD/HND	AX-RAO07300080-DE	7.3	8.0
	HND	AX-RAO01150220-DE	1.15	22.0		ND	AX-RAO07300080-DE	7.3	8.0
2055	HHD	AX-RAO00950320-DE	0.95	32.0	4055	HHD	AX-RAO04600110-DE	4.6	11.0
	HND	AX-RAO00950320-DE	0.95	32.0		HD/HND	AX-RAO04600110-DE	4.6	11.0
2075	HHD	AX-RAO00630430-DE	0.63	43.0	4110	ND	AX-RAO04600110-DE	4.6	11.0
	HND	AX-RAO00630430-DE	0.63	43.0		HHD	AX-RAO04600110-DE	4.6	11.0
2110	HHD	AX-RAO00490640-DE	0.49	64.0	4150	HD/HND	AX-RAO03600160-DE	3.6	16.0
	HND	AX-RAO00490640-DE	0.49	64.0		ND	AX-RAO03600160-DE	3.6	16.0
2150	HHD	AX-RAO00490640-DE	0.49	64.0	4185	HHD	AX-RAO03600160-DE	3.6	16.0
	HND	AX-RAO00390800-DE	0.39	80.0		HD/HND	AX-RAO02500220-DE	2.5	22.0
2185	HHD	AX-RAO00390800-DE	0.39	80.0	4220	ND	AX-RAO02500220-DE	2.5	22.0
	HND	AX-RAO00330950-DE	0.33	95.0		HHD	AX-RAO02500220-DE	2.5	22.0
					4075	HD/HND	AX-RAO02000320-DE	0.20	32.0
						ND	AX-RAO02000320-DE	0.20	32.0
						HHD	AX-RAO02000320-DE	0.20	32.0
					4110	HD/HND	AX-RAO02000320-DE	0.20	32.0
						ND	AX-RAO01650400-DE	0.16	40.0
						HHD	AX-RAO01650400-DE	0.16	40.0
					4150	HD/HND	AX-RAO01650400-DE	0.16	40.0
						ND	AX-RAO01300480-DE	0.13	48.0
						HHD	AX-RAO01300480-DE	0.13	48.0
					4185	HD/HND	AX-RAO01300480-DE	0.13	48.0
						ND	AX-RAO00800750-DE	0.08	75.0
						HHD	AX-RAO00800750-DE	0.08	75.0
4220	HD/HND	AX-RAO00800750-DE	0.08	75.0					
	ND	AX-RAO00800750-DE	0.08	75.0					
	HHD	AX-RAO00800750-DE	0.08	75.0					

Note: This table corresponds with ND/HND rating. When using HD in some case it could be possible to select a smaller size.

1 Chokes

Diameter	Description	Model
21	For 2.2 KW motors or below	AX-FER2102-PE
28	For 15 KW motors or below	AX-FER2815-PE
50	For 45 KW motors or below	AX-FER5045-PE

2 Accessories

Cable

Description	Functions	Model
USB cable	Use a commercially available USB cable that is double-shielded, gold-plated and supports USB 2.0. The Micro B type USB cable can be used.	—

Shield clamps ordering

Description	Model
AB002..AB007 and A2002..A2007	AX-M1-S1
AB015, A2007..A2022 and A4004..A4022	AX-M1-S2
AB022, A2037, and A4030..A4040	AX-M1-S3
AB037, A2055..A2075 and A4055..A4075	AX-M1-S4
A2110..A2150 and A4110..A4150	AX-M1-S5
A2185 and A4185..A4220	AX-M1-S6

Software tools

Description	Functions	Number licenses	Media	Model
Sysmac Studio Standard Edition Ver.1.XX	The Sysmac Studio is the software that provides an integrated environment for setting, programming, debugging and maintenance of machine automation controllers including NJ/NX-series CPU Units, NY-series Industrial PC, EtherCAT Slaves, and HMI. Sysmac Studio runs on the following OS: Windows 7 (32-bit/64-bit version)/Windows 8.1 (32-bit/64-bit version) Windows 10 (32-bit/64-bit version)/Windows 11 (64-bit version) This software provides functions of the Vision Edition. Refer to your local OMRON website for details such as supported models and functions.	(Media only)	Sysmac Studio (32 bit) DVD	SYSMAC-SE200D
		(Media only)	Sysmac Studio (64 bit) DVD	SYSMAC-SE200D-64
		1 license		SYSMAC-SE201L
Sysmac Studio Drive Edition Ver.1.XX	Sysmac Studio Drive Edition is a limited license that provides selected functions required for 1S-series Servo, G5-series Servo and M1 Series Inverter System settings. Because this product is a license only, you need the Sysmac Studio Standard Edition DVD media to install it.	1 license	-	SYSMAC-DE001L
Omron Drives Mobile App	Windows and Android application that allows to communicate through USB with the drive for copy and paste parameter or edit the protocol parameters. Available in Google Play Store and Microsoft Store.	Free		Omron Drives

3 Braking resistor

Voltage	3G3M1-A□	Conn. min. resistance	Resistor fast stop (10s not cyclic)			Braking resistor (3% ED, 10 sec)			Braking resistor (10% ED, 10sec)		
			Model	Specifications		Model	Specifications		Model	Specifications	
1 phase 200 V	B002	100 Ω	AX-REM00K1100-IE	100 W	100 Ω	AX-REM00K1100-IE	100 W	100 Ω	AX-REM00K2100-IE	200 W	100 Ω
	B004		AX-REM00K1100-IE	100 W	100 Ω	AX-REM00K1100-IE	100 W	100 Ω	AX-REM00K2100-IE	200 W	100 Ω
	B007		AX-REM00K1100-IE	100 W	100 Ω	AX-REM00K1100-IE	100 W	100 Ω	AX-REM00K2100-IE	200 W	100 Ω
	B015	40 Ω	AX-REM00K2040-IE	200 W	40 Ω	AX-REM00K2050-IE	200 W	50 Ω	AX-REM00K4050-IE	400 W	50 Ω
	B022		AX-REM00K2040-IE	200 W	40 Ω	AX-REM00K2050-IE	200 W	50 Ω	AX-REM00K4050-IE	400 W	50 Ω
	B037		AX-REM00K4040-IE	400 W	40 Ω	AX-REM00K4050-IE	400 W	50 Ω	AX-REM00K6050-IE	600 W	50 Ω
3 phase 400 V	4004	200 Ω	AX-REM00K1200-IE	100 W	200 Ω	AX-REM00K1200-IE	100 W	200 Ω	AX-REM00K4200-IE	400 W	200 Ω
	4007		AX-REM00K1200-IE	100 W	200 Ω	AX-REM00K1200-IE	100 W	200 Ω	AX-REM00K4200-IE	400 W	200 Ω
	4015	160 Ω	AX-REM00K3160-IE	300 W	160 Ω	AX-REM00K1200-IE	100 W	200 Ω	AX-REM00K4200-IE	400 W	200 Ω
	4022		AX-REM00K3160-IE	300 W	160 Ω	AX-REM00K1200-IE	100 W	200 Ω	AX-REM00K4200-IE	400 W	200 Ω
	4030	130 Ω	AX-REM00K4130-IE	400 W	130 Ω	AX-REM00K2150-IE	200 W	150 Ω	AX-REM00K6150-IE	600 W	150 Ω
	4040		AX-REM00K4130-IE	400 W	130 Ω	AX-REM00K2150-IE	200 W	150 Ω	AX-REM00K6150-IE	600 W	150 Ω
	4055	80 Ω	AX-REM00K6080-IE	600 W	80 Ω	AX-REM00K3100-IE	300 W	100 Ω	AX-REM00K9100-IE	900 W	100 Ω
	4075	60 Ω	AX-REM00K9060-IE	900 W	60 Ω	AX-REM00K4070-IE	400 W	70 Ω	AX-REM01K3070-IE	1300 W	70 Ω
	4110	40 Ω	AX-REM00K9040-IE	900 W	40 Ω	AX-REM00K4050-IE	400 W	50 Ω	AX-REM01K9050-IE	1900 W	50 Ω
	4150	34.4 Ω	AX-REM00K9040-IE	900 W	40 Ω	AX-REM00K4050-IE	400 W	50 Ω	AX-REM01K9050-IE	1900 W	50 Ω
	4185	16 Ω	AX-REM01K9017-IE	1900 W	17 Ω	AX-REM01K1020-IE	1100 W	20 Ω	AX-REM03K5020-IE	3500 W	20 Ω
4220	AX-REM01K9017-IE		1900 W	17 Ω	AX-REM01K1020-IE	1100 W	20 Ω	AX-REM03K5020-IE	3500 W	20 Ω	
3 phase 200 V	2002	100 Ω	AX-REM00K1100-IE	100 W	100 Ω	AX-REM00K1100-IE	100 W	100 Ω	AX-REM00K2100-IE	200 W	100 Ω
	2004		AX-REM00K1100-IE	100 W	100 Ω	AX-REM00K1100-IE	100 W	100 Ω	AX-REM00K2100-IE	200 W	100 Ω
	2007		AX-REM00K1100-IE	100 W	100 Ω	AX-REM00K1100-IE	100 W	100 Ω	AX-REM00K2100-IE	200 W	100 Ω
	2015	40 Ω	AX-REM00K2040-IE	200 W	40 Ω	AX-REM00K2050-IE	200 W	50 Ω	AX-REM00K4050-IE	400 W	50 Ω
	2022		AX-REM00K2040-IE	200 W	40 Ω	AX-REM00K2050-IE	200 W	50 Ω	AX-REM00K4050-IE	400 W	50 Ω
	2037	33 Ω	AX-REM00K4035-IE	400 W	35 Ω	AX-REM00K2040-IE	200 W	40 Ω	AX-REM00K4040-IE	400 W	40 Ω
	2055	20 Ω	AX-REM00K4020-IE	400 W	20 Ω	AX-REM00K3025-IE	300 W	25 Ω	AX-REM00K6030-IE	600 W	30 Ω
	2075	15 Ω	AX-REM00K6015-IE	600 W	15 Ω	AX-REM00K4020-IE	400 W	20 Ω	AX-REM00K9020-IE	900 W	20 Ω
	2110	10 Ω	AX-REM00K9010-IE	900 W	10 Ω	AX-REM00K6015-IE	600 W	15 Ω	AX-REM001K1015-IE	1100 W	15 Ω
	2150	8.6 Ω	AX-REM00K9010-IE	900 W	10 Ω	AX-REM00K6015-IE	600 W	15 Ω	AX-REM001K1015-IE	1100 W	15 Ω
2185	4 Ω	AX-REM02K1004-IE	2000 W	4 Ω	AX-REM00K9006-IE	900 W	6 Ω	AX-REM03K5006-IE	3500 W	6 Ω	

ALL DIMENSIONS SHOWN ARE IN MILLIMETERS.
To convert millimeters into inches, multiply by 0.03937. To convert grams into ounces, multiply by 0.03527.