



Riu Güell, 34  
E-17180 Vilablareix – Girona (Spain)  
Tel +34 972 244 606  
e-Mail: [tecnoelectric@teg.es](mailto:tecnoelectric@teg.es)

---

# TEG TOPS

## FOR OMRON AUTONOMOUS MOBILE ROBOTS

---

Brochure

30th September 2024

---

## INDEX

---

<b>AMR121 – SIDE ROLLERS CONVEYOR .....</b>	<b>3</b>
Technical specifications .....	3
Available options.....	3
Dimensions.....	4
Pictures.....	5
<b>AMR141 – 3-LEVEL SIDE BELT CONVEYOR .....</b>	<b>7</b>
Technical specifications .....	7
Available options.....	7
Dimensions.....	8
Pictures.....	9
<b>AMR151-171-172 – 2-BELT DOUBLE SIDE CONVEYOR .....</b>	<b>10</b>
Technical specifications .....	10
Available options.....	10
Dimensions.....	11
Pictures.....	12
<b>AMR312 – CART TRANSPORTER.....</b>	<b>13</b>
Technical specifications .....	13
Available options.....	13
Dimensions.....	14
Pictures.....	15
<b>AMR411 – PALLET LIFT HANDLER .....</b>	<b>16</b>
Technical specifications .....	16
Available options.....	16
Dimensions.....	17
Pictures.....	19
<b>AMR421 – BOX LIFTER .....</b>	<b>20</b>
Technical specifications .....	20
Available options.....	20

Dimensions.....	21
Pictures.....	22
<b>AMR441 – TABLE/CART LIFTER .....</b>	<b>23</b>
Technical specifications .....	23
Available options.....	23
Dimensions.....	24
Pictures.....	25
<b>AMR611 – DOUBLE LIFTER SIDE BELT CONVEYOR .....</b>	<b>26</b>
Technical specifications .....	26
Available options.....	26
Dimensions.....	27
<b>AMR9X1 – MOBILE MANIPULATORS .....</b>	<b>28</b>
Technical specifications .....	28
Available options.....	28
Dimensions.....	29
Pictures.....	30

---

## AMR121 – SIDE ROLLERS CONVEYOR

---

For Omron LD-60/LD-90

### Technical specifications

---

Side conveyor with light design for increasing maximum payload.

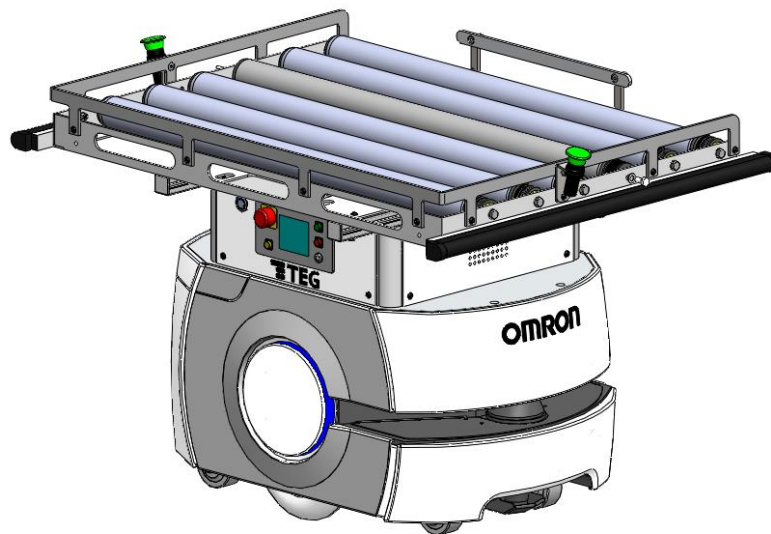

- Light design for payloads up to 60 kg (LD-90)
- Materials: Aluminium, with polycarbonate covers
- Colour: White and gray
- Max payload: 800 x 600 mm
- Height: 600 mm, configurable
- Safety edges included
- Controlled by Sysmac
- Stainless steel and/or green plastic, configurable pushbuttons included
- Double side assembly (left or right)
- 4 payload detectors for 2-boxes transportation

### Available options

---

- Side lasers
- Acuity
- Beacon
- Extra pushbuttons

Dimensions

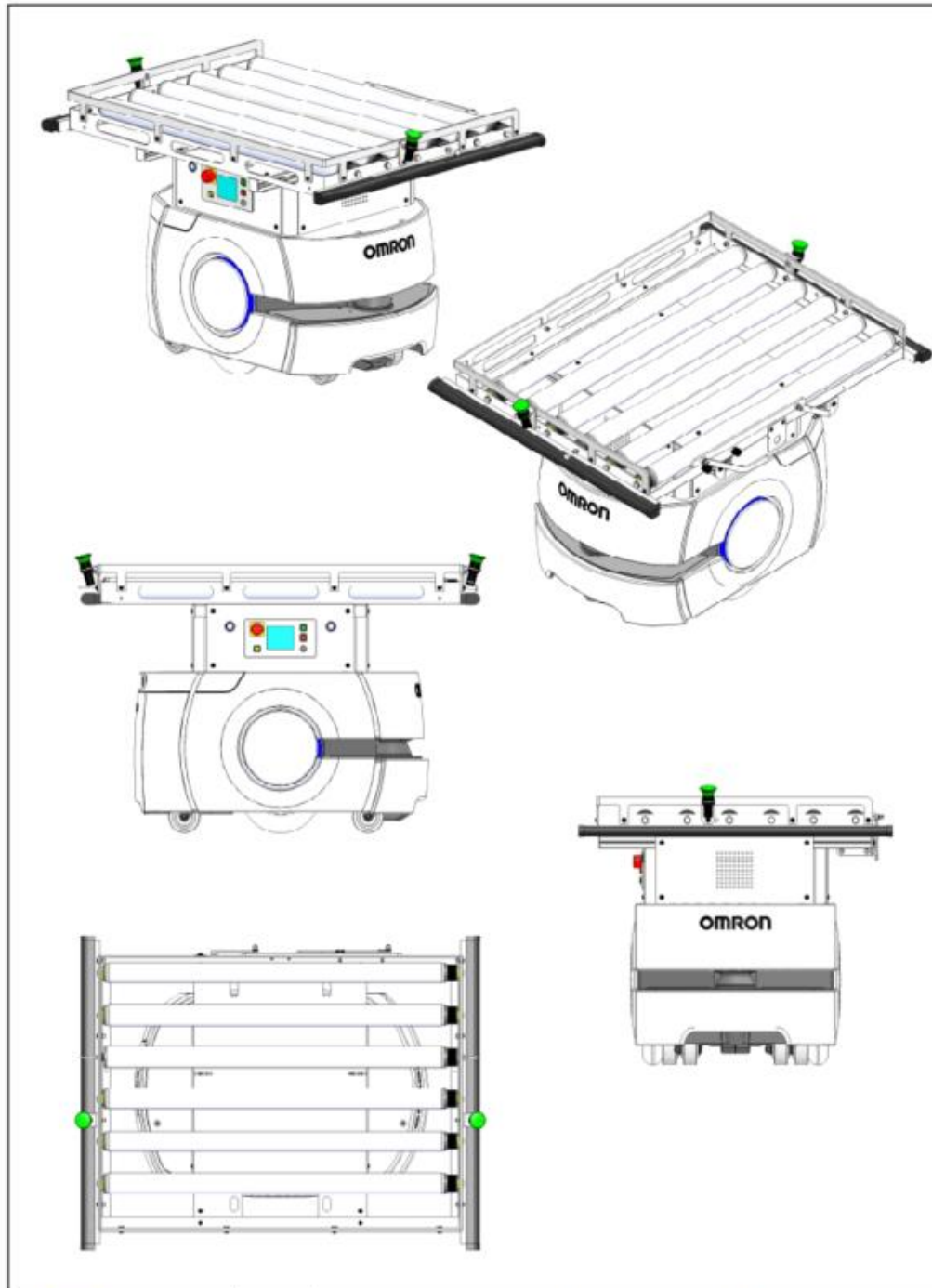

 Tecno-Eléctric Girona s.l.			DESCRIPCIÓN	TRANSPORTADOR RODETS LATERAL						
			CONJUNTO	LD-90						
DISEÑADO	FECHA	NOMBRE	MAQUINA	-						
VERIFICADO			Hoja	NUMERO DE ARTICULO	A4	ESCALA	1:10	IP PLANO	AMR121	ORDEN MOD.
			1 de 1							

Pictures

---





<https://www.youtube.com/watch?v=9fKPrsU9jOc>

---

## AMR141 – 3-LEVEL SIDE BELT CONVEYOR

---

For Omron LD-250

### Technical specifications

---

Side conveyor with high capacity design.

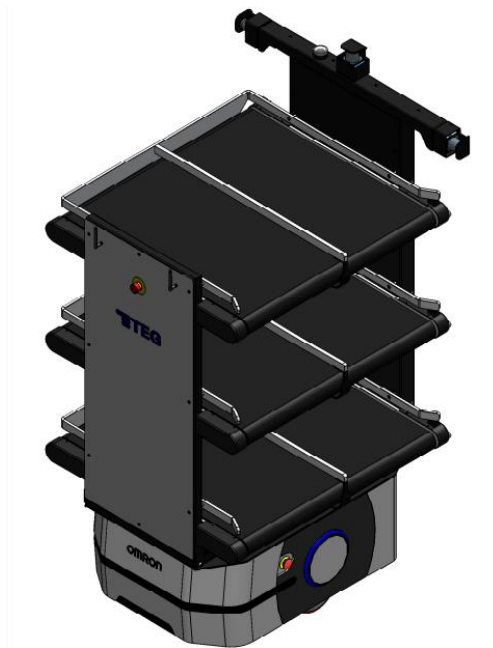

- 3 levels for increased capacity
- Materials: Steel and aluminium
- Colour: Black and gray
- Max payload: 800 x 800 mm per level
- Heights: 550 - 1000 - 1450 mm
- E-Stop pushbuttons included
- Controlled by Sysmac
- Stainless steel pushbuttons included
- Double side assembly (left or right)

### Available options

---

- Side lasers
- Rear laser or additional front laser (at the top)
- Acuity
- Beacon
- Extra pushbuttons
- Central spacer
- Electric actuators for karakuri activation
- Frontal blue spotlight



Dimensions

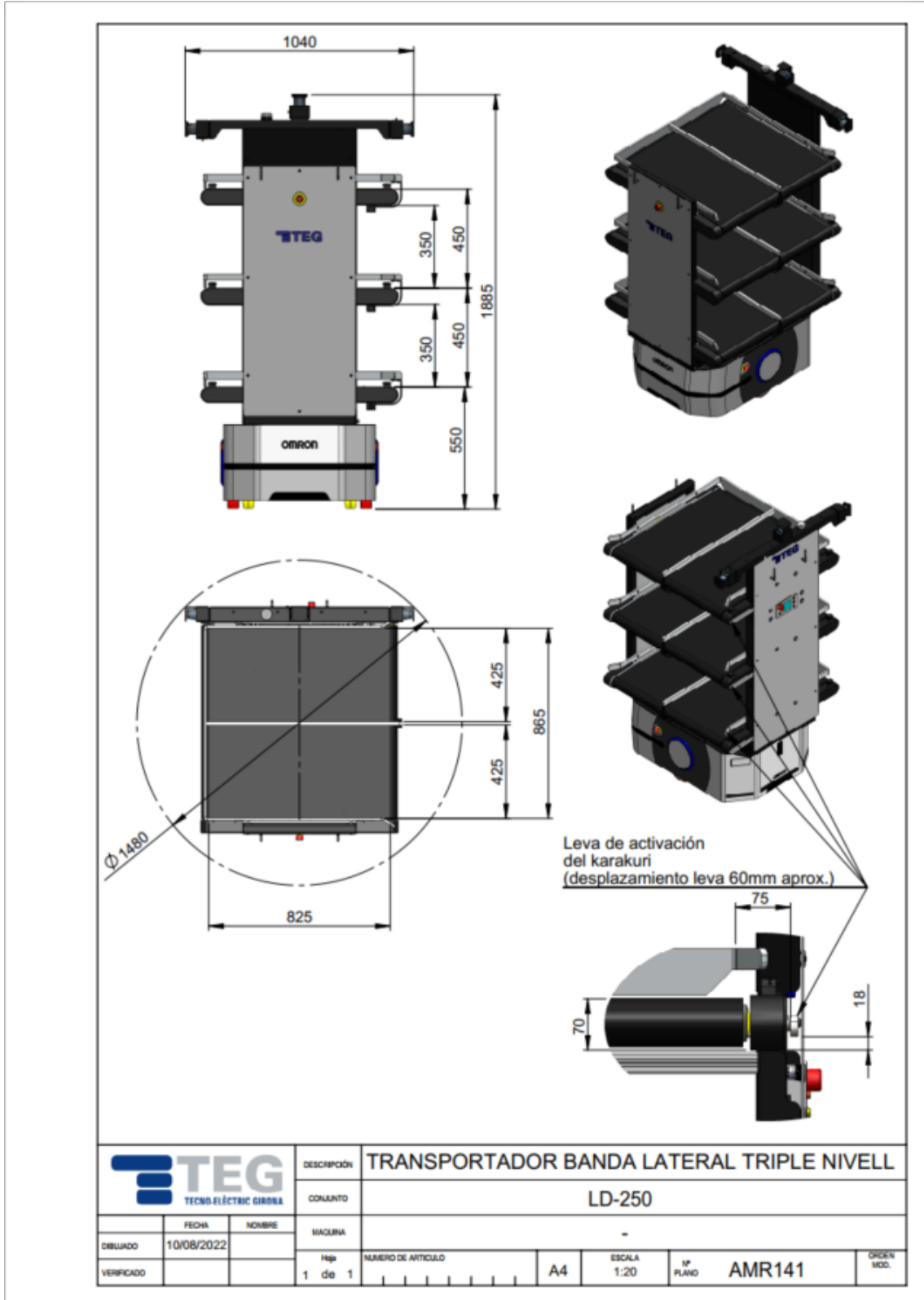

Pictures

---



---

## AMR151-171-172 – 2-BELT DOUBLE SIDE CONVEYOR

---

For Omron LD-250 (AMR171-172). Available model for LD-90 (AMR151)

### Technical specifications

---

Independent double box, double side transfer.



- 2 belts for front and back independent transfers
- Materials: Steel and aluminium, with polycarbonate covers
- Colour: White and black
- Max payload: 2 x 400 x 600 mm
- Height: 600 mm, configurable
- E-Stop pushbuttons included
- Controlled by Sysmac
- Stainless steel pushbuttons included
- Configurable total height

### Available options

---

- Side lasers
- Acuity
- Beacon
- Extra pushbuttons
- Central spacer
- Electric actuators for karakuri activation
- Special model **TEG AMR151** for LD-90
- Frontal blue spotlight

Dimensions

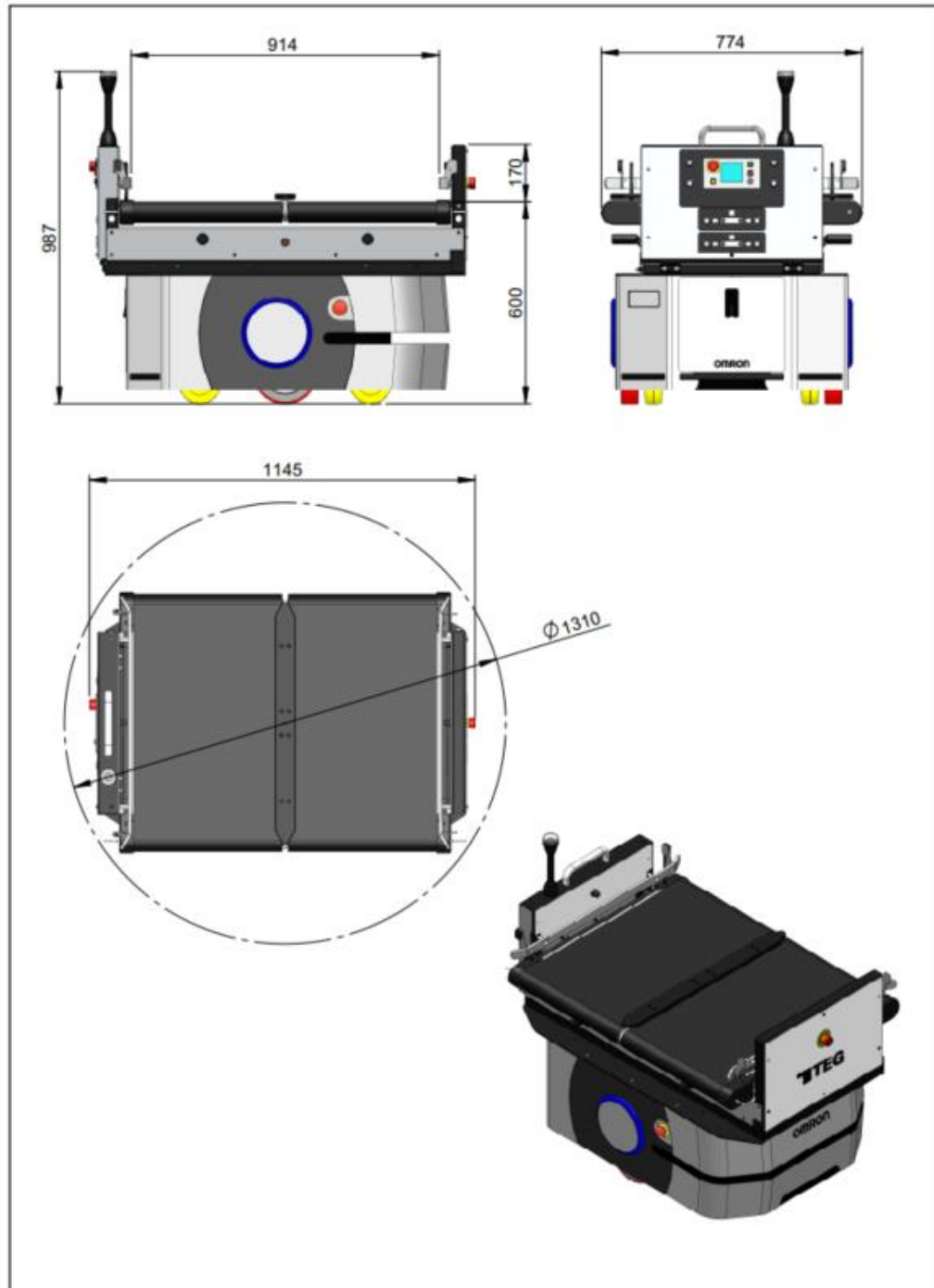

 Tecno-Eléctric Girona s.l.			DESCRIPCIÓN	TRANSPORTADOR DOBLE BANDA LATERAL					
			CONJUNTO	LD-250					
	FECHA	NOMBRE	MAQUINA	-					
DISEÑADO	06/06/2023		Hop	NÚMERO DE ARTÍCULO	A4	ESCALA 1:15	IP PLANO	AMR172	ORDEN MOD.
VERIFICADO			1 de 1						

Pictures

---

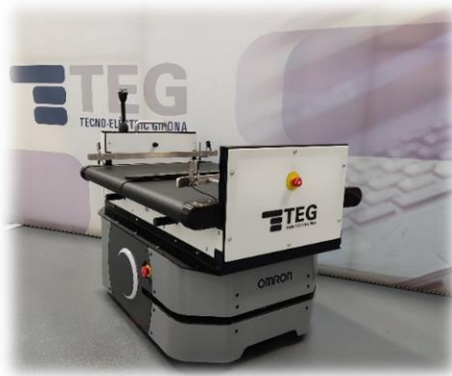

---

## AMR312 – CART TRANSPORTER

---

For Omron LD-90x or LD-90

### Technical specifications

---

Compatible with LD-105CT and LD-130CT AMRs and carts.

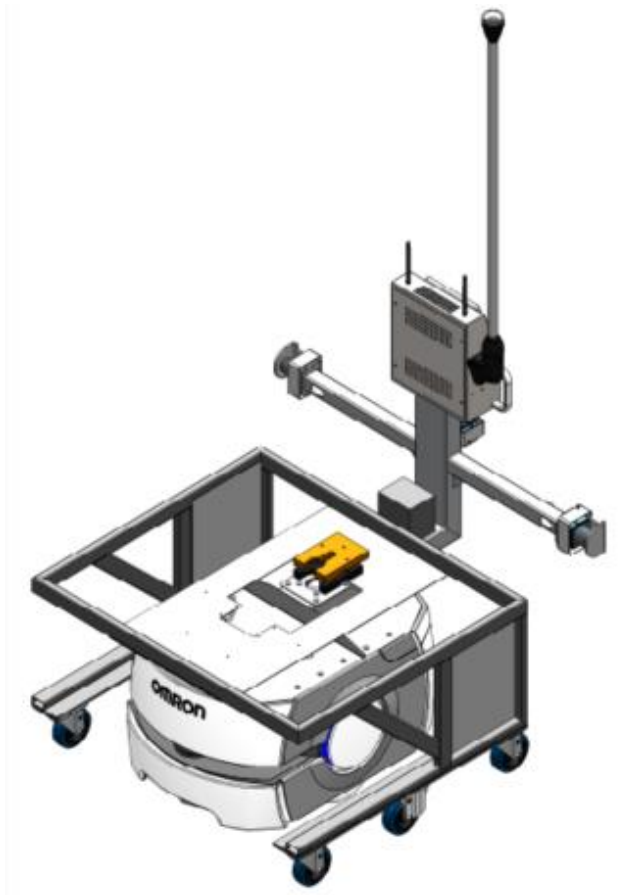

- Compatible replacement for LD-105CT and LD-130CT
- Materials: Aluminium
- Colour: White
- Configurable back length
- Beacon included (configurable height)
- Side lasers included (configurable total width)
- Rear laser included
- Cart capturing using CAPS + HMI with I/O control
- Compatible with Standard Cart Transporter and Standard Carts operation & payload (Adapter part required for every cart)

### Available options

---

- Acuity

Dimensions

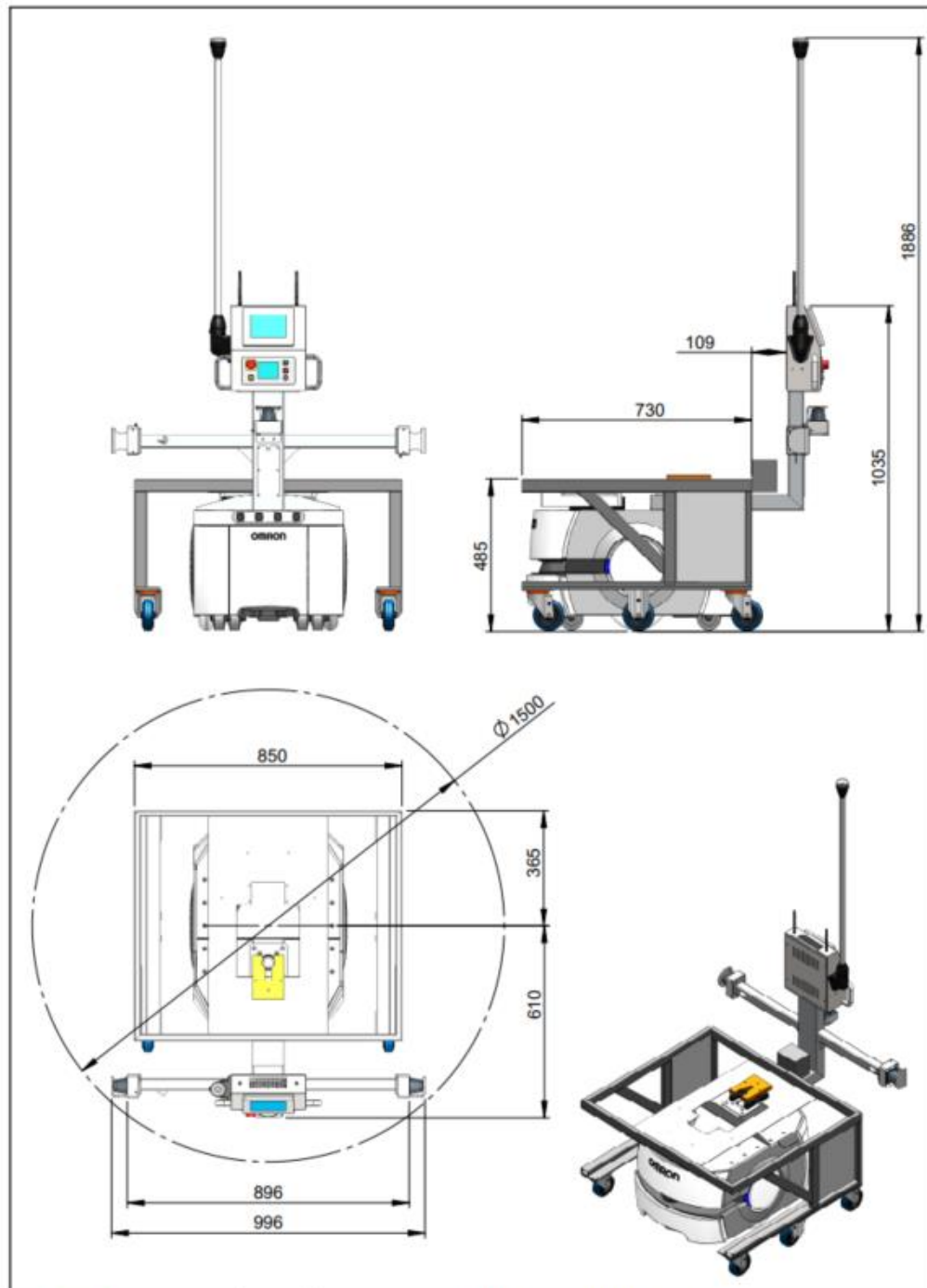

 Tecno-Eléctric Girona s.L.		DESCRIPCIÓN	CART TRANSPORTER TEG				
		CONJUNTO	LD-90				
	FECHA	NOMBRE	MAQUINA				
DIBUJADO	09/03/2023		Hoja	NUMERO DE ARTICULO	ESCALA	1º PLANO	ORDEN MOD.
VERIFICADO			1 de 1		A4	AMR312	

Pictures

---

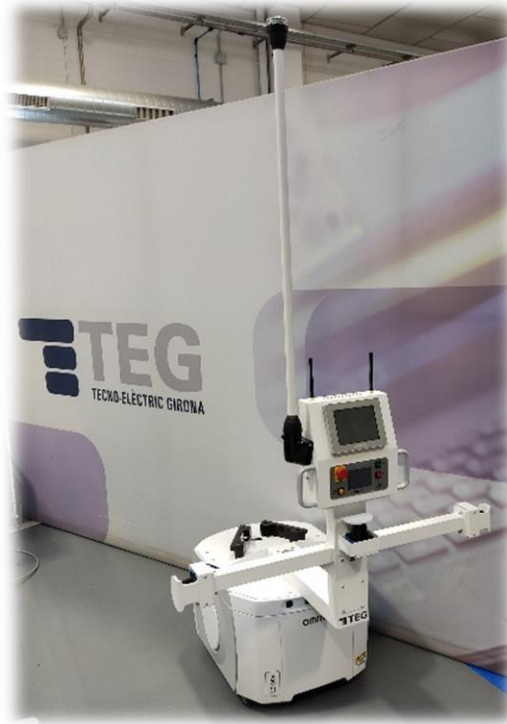



---

## AMR411 – PALLET LIFT HANDLER

---

For Omron LD-250

### Technical specifications

---

Special design for pallet transportation.

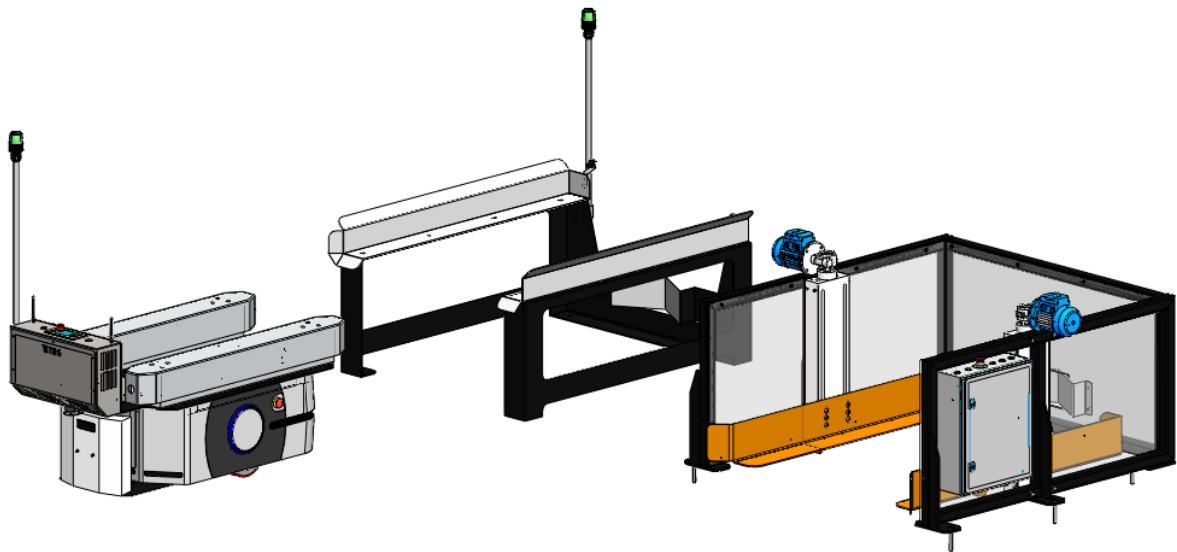

- Pallets frontal pickup/dropoff from/to tables and/or special conveyors
- Steel, stainless steel and aluminium structure
- Black and gray colours
- Configurable pallet dimensions
- Controlled by Sysmac
- Configurable, stainless-steel pushbuttons

### Available options

---

- Side lasers (configurable total width)
- Rear laser
- Acuity
- Beacon
- Extra pushbuttons
- Omron NA touchscreen
- **TEG POA901** fixed table
- **TEG POA911** lift table
- Customized conveyor

Dimensions

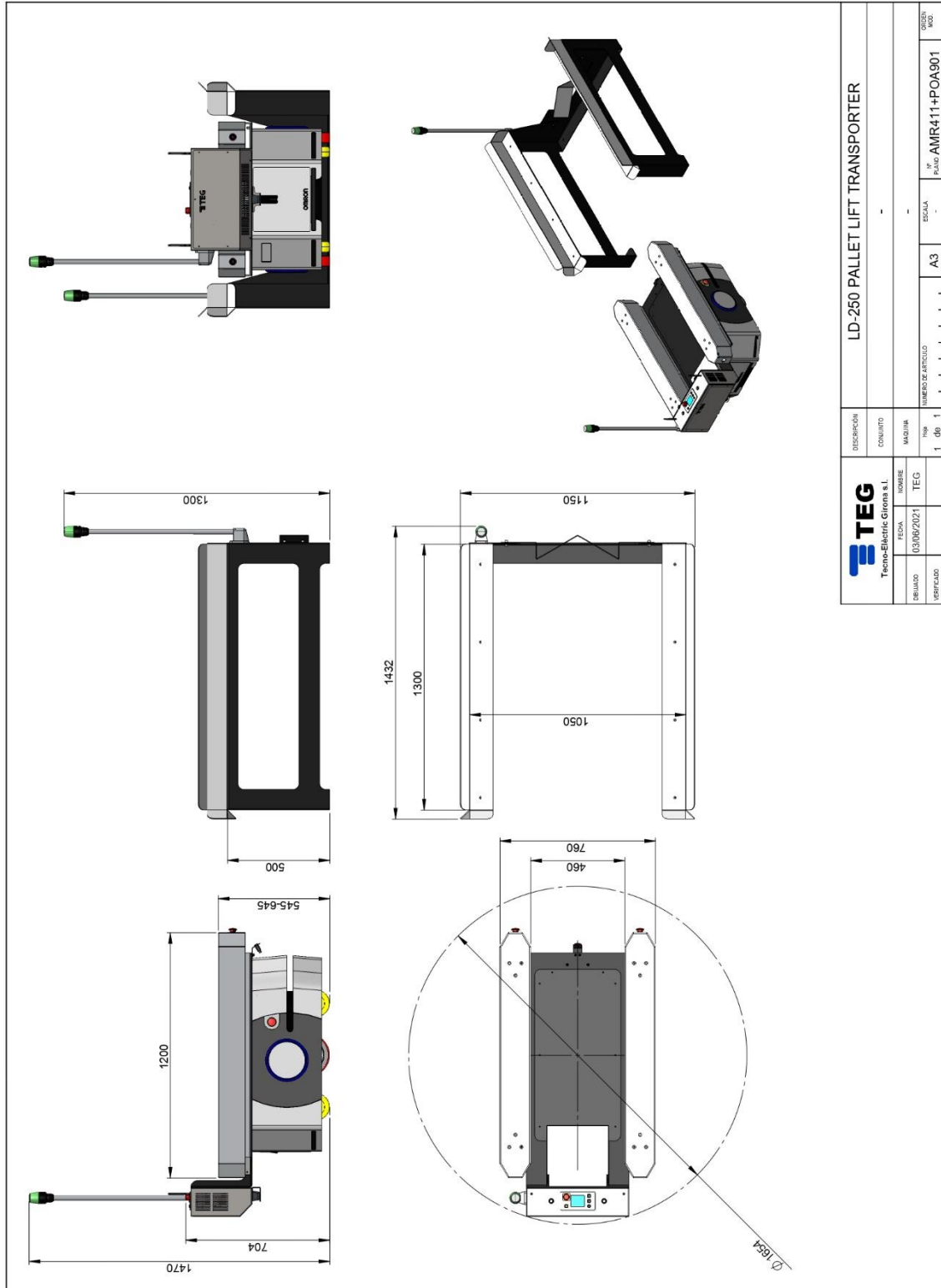

<b>TEG</b> Tecnio-Eléctric Giirona s.l.		DESCRIPCIÓN	LD-250 PALLET LIFT TRANSPORTER	
FECHA	10/06/2021	CONSULTO		
NOMBRE	TEG	MAQUINA		
DELIBADO		NUM.	1	006
VERIFICADO		NUMERO DE PIECE		
		ESCALA	A3	
		PLANO	AMR411+POA901	
		ORDEN	MOD.	

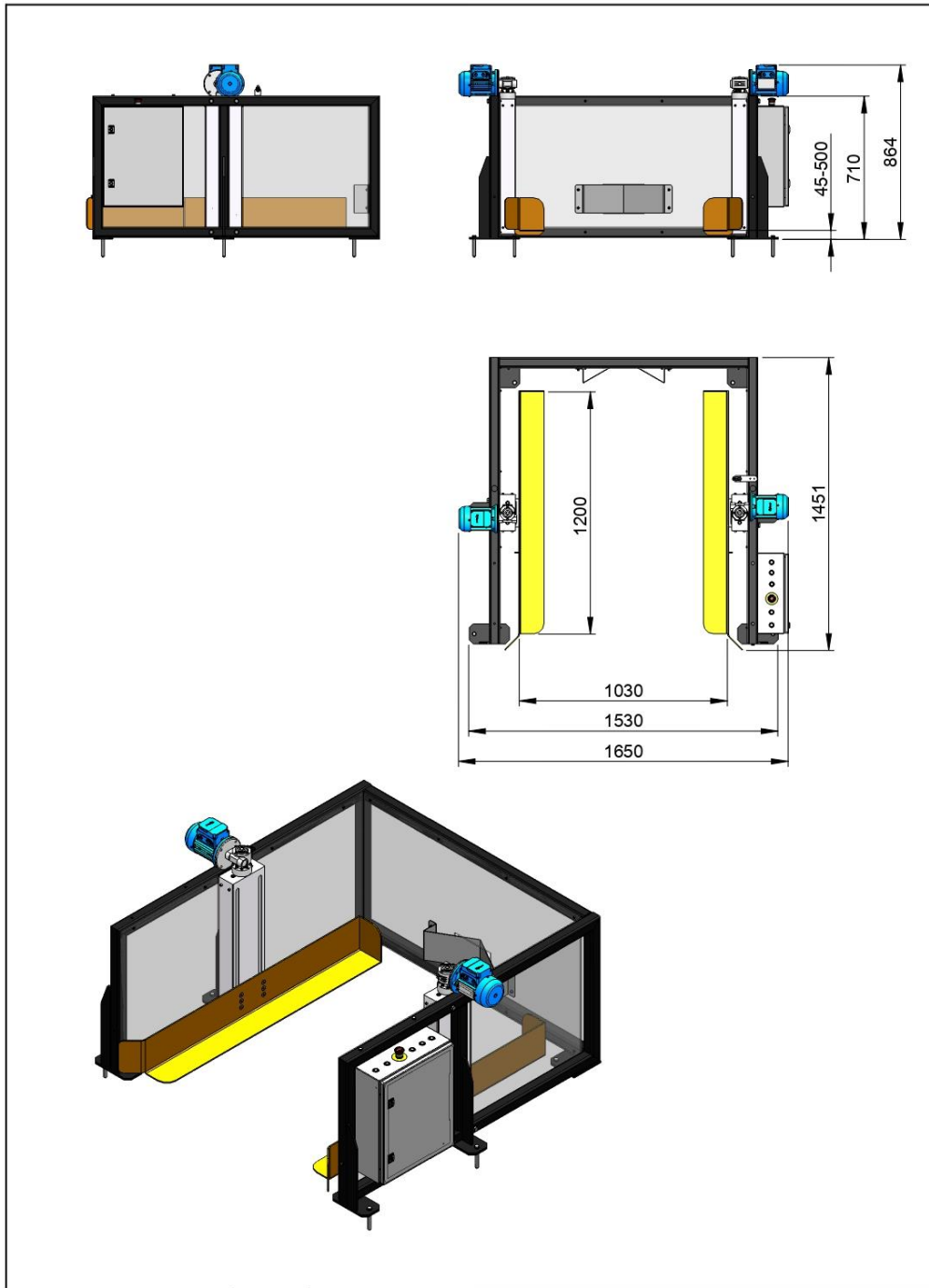

 <b>TEG</b> Tecno-Eléctric Girona s.l.			DESCRIPCIÓN	AUTOMATIC PALLET LIFTER 1200X1000				
			CONJUNTO	-				
DIBUJADO	FECHA	NOMBRE	MAQUINA	-				
VERIFICADO			Hoja	NUMERO DE ARTICULO	A4	ESCALA	Nº PLANO	ORDEN MOD.
			1 de 1			-	POA911	

Pictures



---

## AMR421 – BOX LIFTER

---

For Omron LD-90

### Technical specifications

---

Special design for samples transportation.

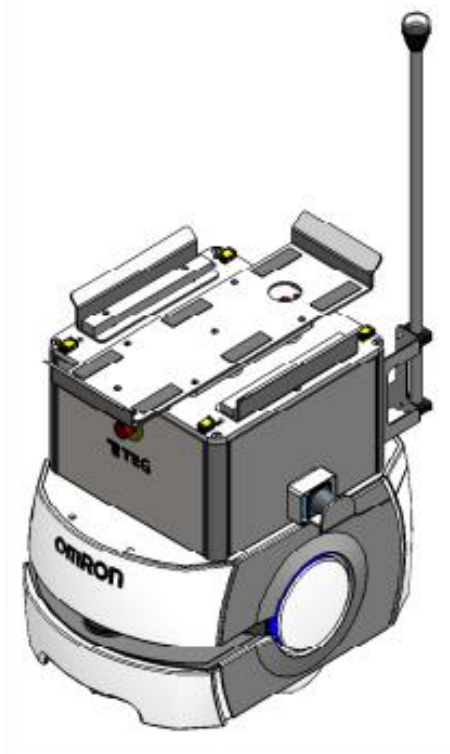

- Forward pickup/dropoff from/to special tables
- Steel, stainless steel and aluminium structure
- White and gray colours
- Box dimensions: 600 x 400 mm (configurable)
- Controlled by Sysmac or MATE
- Configurable, stainless-steel pushbuttons

### Available options

---

- Side lasers
- Beacon
- Extra pushbuttons
- **TEG POA921** fixed table
- Customized table
- Frontal blue spotlight

Dimensions

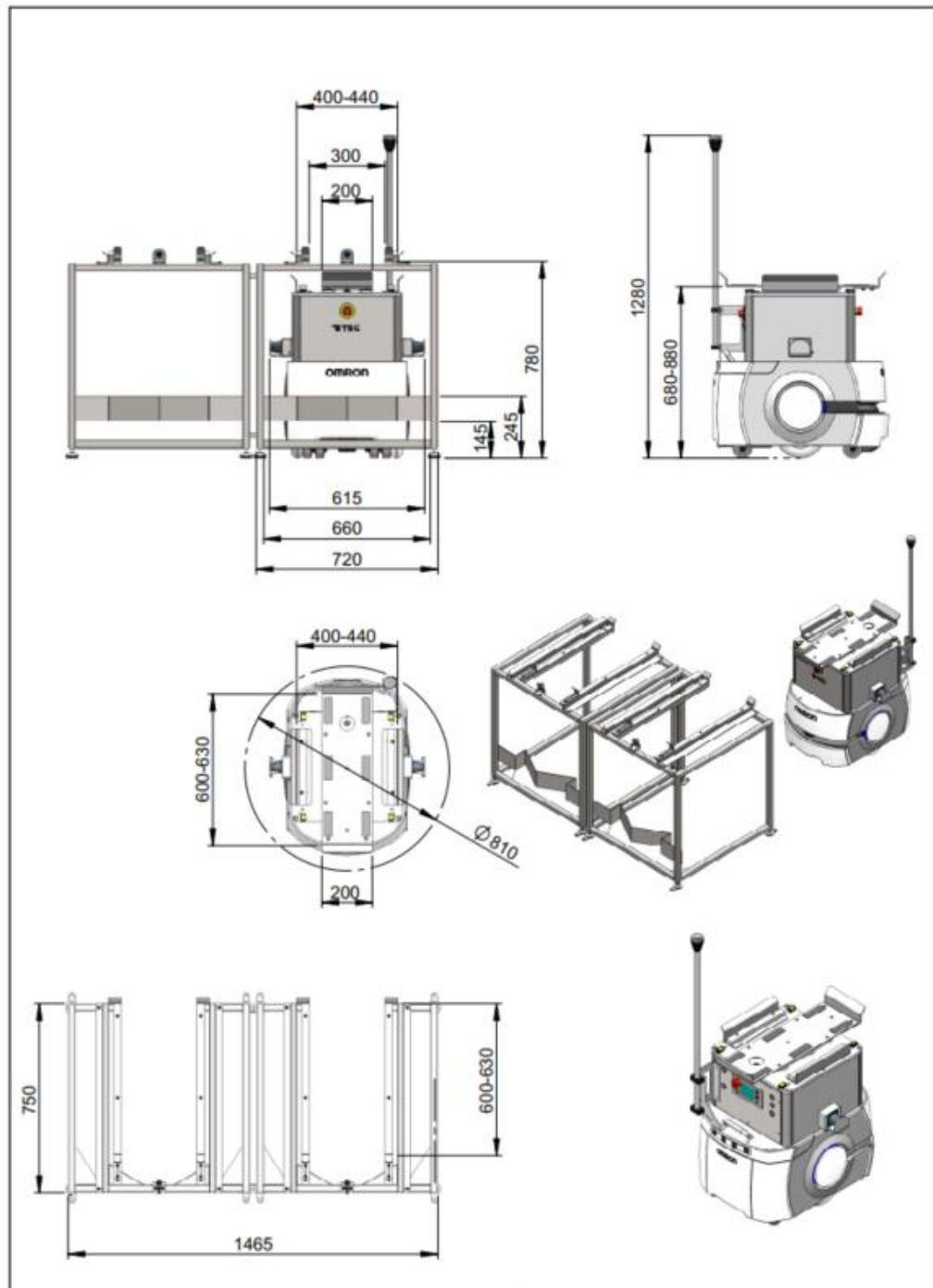

 Tecno-Eléctric Girona s.L.		DESCRIPCIÓN	ELEVADOR CAIXES					
		CONJUNTO	LD-90					
FECHA	NOMBRE	MAQUINA	-					
DIBUJADO 19/08/2022		Hop	NÚMERO DE ARTÍCULO	A4	ESCALA 1:20	Nº PLANO	AMR421 + POA921	ORIGEN MOL.
VERIFICADO		1 de 1						

Pictures

---



---

## AMR441 – TABLE/CART LIFTER

---

For Omron LD-90

### Technical specifications

---



- Forward pickup/dropoff of special tables
- Steel and aluminium structure
- White and black colours
- Configurable table/cart dimensions
- Controlled by Sysmac
- Configurable, stainless-steel pushbuttons

### Available options

---

- Side lasers
- Beacon
- Extra pushbuttons
- Customized tables or carts



Dimensions

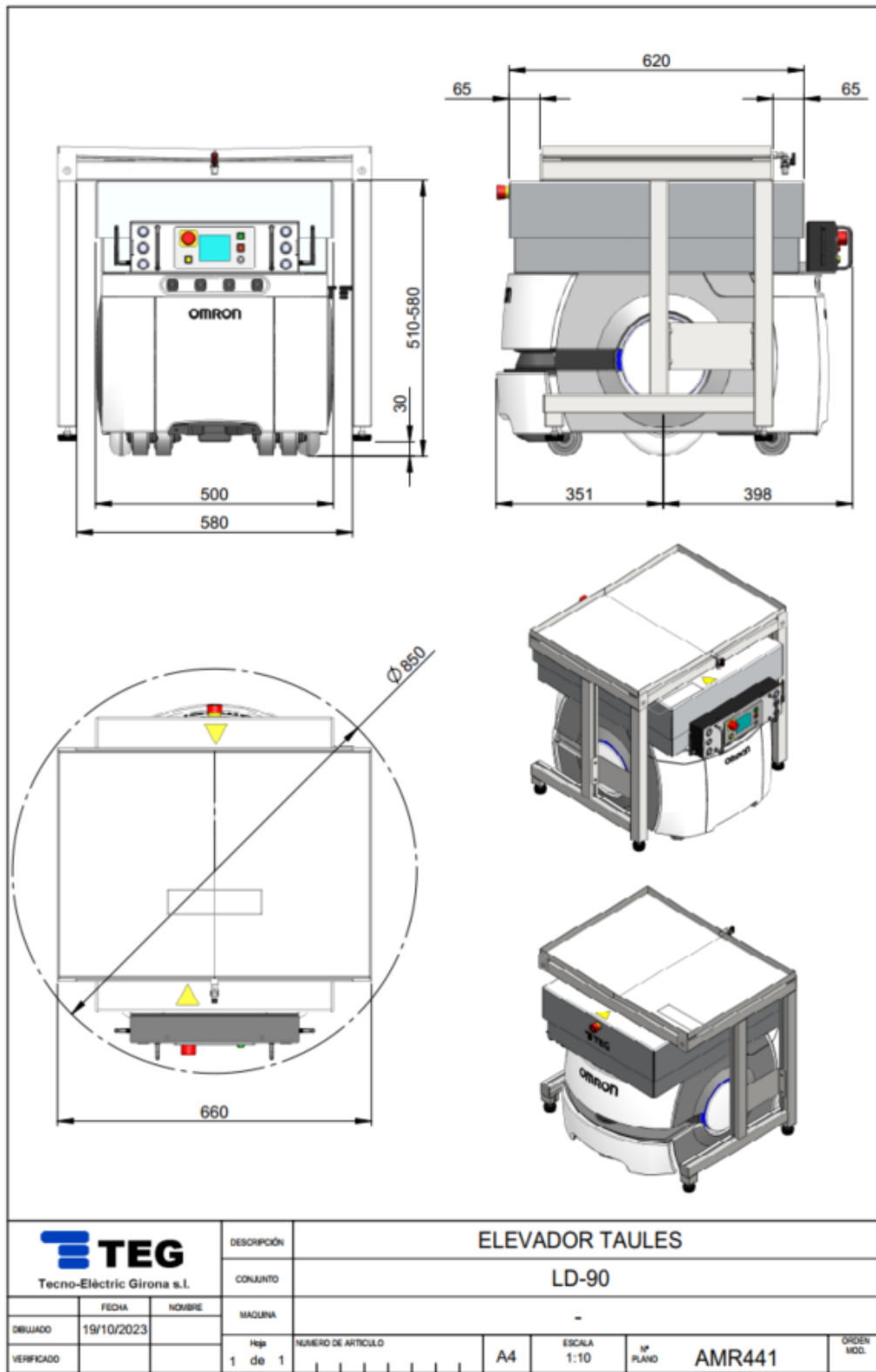

Pictures

---



---

## AMR611 – DOUBLE LIFTER SIDE BELT CONVEYOR

---

For Omron LD-250

### Technical specifications

---

Double lifter conveyor, double side, adjustable transfer height.



- Double conveyor, adjustable pickup/dropoff height (by communications)
- Materials: Steel and aluminium
- Colour: White and black
- Max payload: 2 x 800 x 600 mm
- Height: 700 - 1300 mm, configurable
- E-Stop pushbuttons included
- Controlled by Sysmac
- NA touchscreen included
- Box stoppers included
- Side lasers included

### Available options

---

- Acuity
- Beacon
- Frontal blue spotlight
- Customized conveyor



---

## AMR9x1 – MOBILE MANIPULATORS

---

For Omron LD-250. Models for LD-90 also available.

### Technical specifications

---

**TEG AMR921 MOMA 250:** Standard LD-250 + TM12 Mobile Manipulator

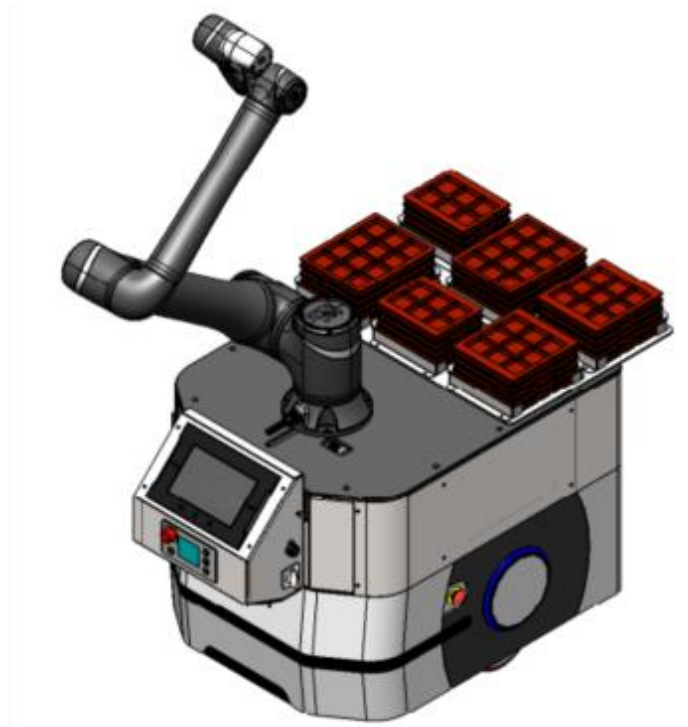

- Standard model for TM12
- Materials: Steel and aluminium
- Colour: Black and gray
- Configurable height from 650 mm
- Safety PLC included
- Controlled by Sysmac

### Available options

---

- Side lasers
- Additional OS32C safety lasers
- NA touchscreen
- Second battery
- Customized payload base
- Customized TM gripper
- Customized TM height
- LD-90 + TM5 or TM7 options
- Other customizations

Dimensions

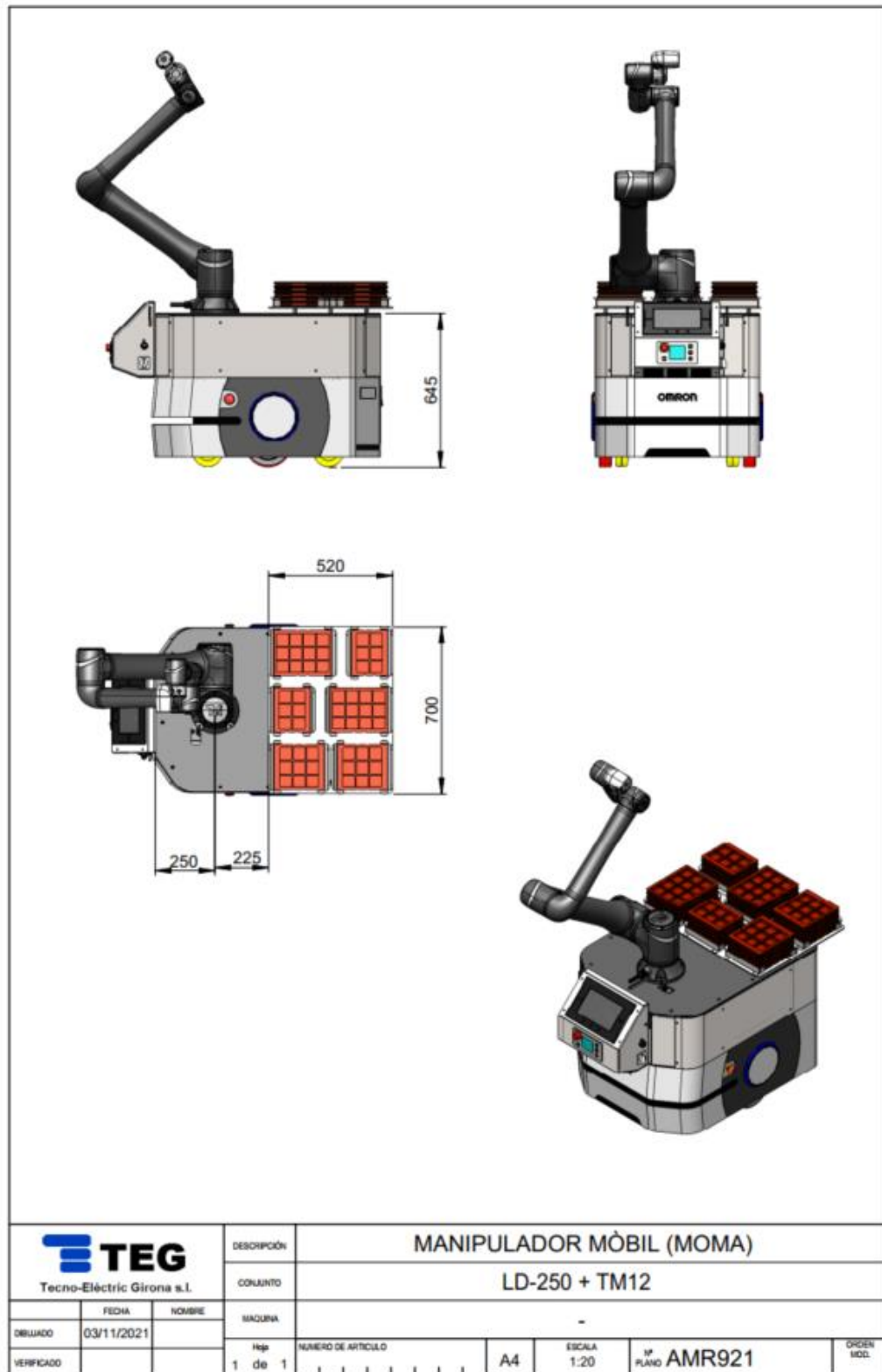

Pictures

---

