

Intelligent. Easy. Cost-Effective. Transportation.

AMR



The Mechafant is an autonomous mobile robot (AMR), that can handle payloads up to 700kg.

It is designed for usage in environments where people move and unexpected obstacles can occur. Additionally it is equipped with blue spot safety lights to improve the recognizability in difficult working environments.

Navigation



The Mechafant has intelligent navigation and motion control. Combined with a software for automatic map generation and orientation, the mobile robot moves autonomously and safely inside a defined working area.

Based on the abilities of the Mechafant modifications to the shopfloor are not necessary.

Superstructure



Due to the unique superstructure with hydraulic driven forks the Mechafant can pick up euro pallets directly from the shopfloor without any assisting machinery. During the transportation process the euro pallets are set on the loading area on top of the robot. The loading and unloading can be in heights up to 500mm above floor.

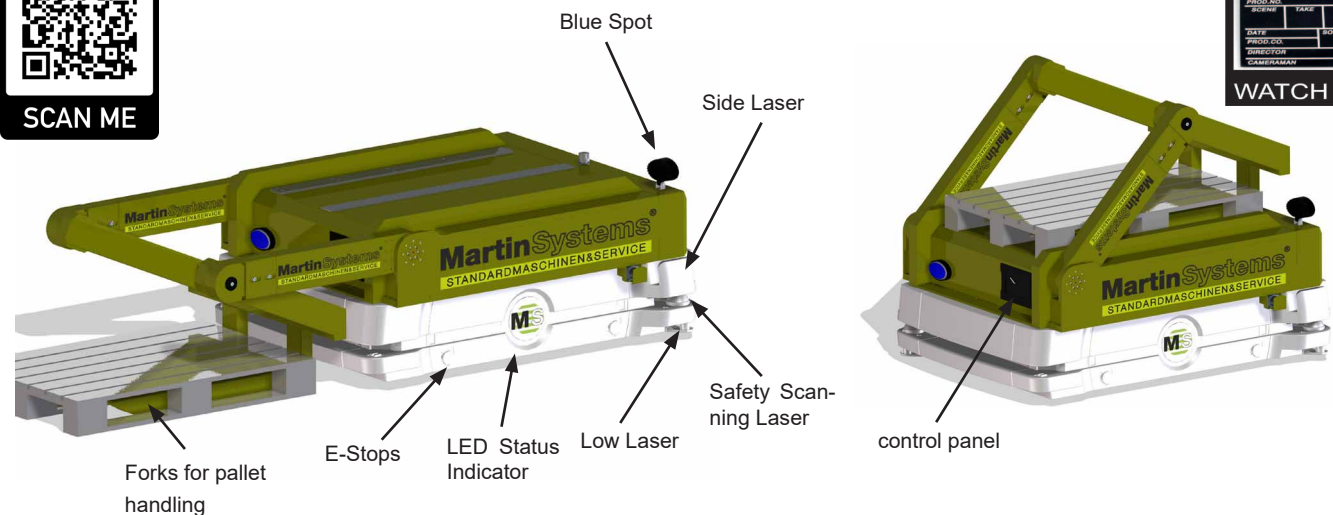

Safety



People and objects approaching the Mechafant are detected by two safety scanning lasers with a coverage angle of 360°. If a person or object comes too close to the Mechafant, it will safely slow down or stop until its safety area is clear again.

The load is monitored by two additional side lasers to detect objects that protrude over the outline of the Mechafant.

Fleet Management



The fleet management tasks are executed by intelligent software that performs traffic control, job distribution and navigation of the robots. It constantly monitors all robots regarding their position, orientation and status. Based on this data the software determines which robot has to perform the next task to ensure the best possible flow of goods.

Application



The Mechafant offers a wide range of applications in multiple sectors. It can unfold its full potential by linking machinery and manual workstations with different types of storage facilities.

Please contact us for more information on how to streamline your flow of goods with autonomous robots.

Technical Data



Options.

High Accuracy Positioning System (HAPS) to move in applications that require tight tolerances

Cell Alignment Positioning System (CAPS) for a fast position recognition and high accuracy

Fixed push-buttons to activate a movement command

Call-Button to configure two digital In- and Outputs (e.g. open roll-up door, request elevator, request device, etc.)

Light beacon to display the running status

Remote access in case of any disruption with END-to-END connection

Panel.

7 Zoll LCD-Display

Interfaces.

W-LAN 802,11 a/b/g/n/ac

Ethernet Ports (1xMaintenance, 1xUser, 2xInternal)

8 digital In- and Outputs

4 analog In- and Outputs

Digital Audio Out

Emergency Stop Button

Review Mechafant-L

Payload max.	Pickup Height max.	Lifting time	Speed (max.)	Rotating speed	Traversable Gap	Traversable Step
700kg*	400mm	30sec**	1.800mm/s	60°/s	15 mm	10 mm

Power Supply

Voltage	Capacity	Weight	Run time (loaded)	Recharge time (20-80%)	Battery Expectancy	Charging Method	Power Supply
42-57VDC	70Ah	68kg	9h	24min	9.000 load cycles	Automatic	230V or 400V

*special edition 1,2to

**customizable

MHP 08500

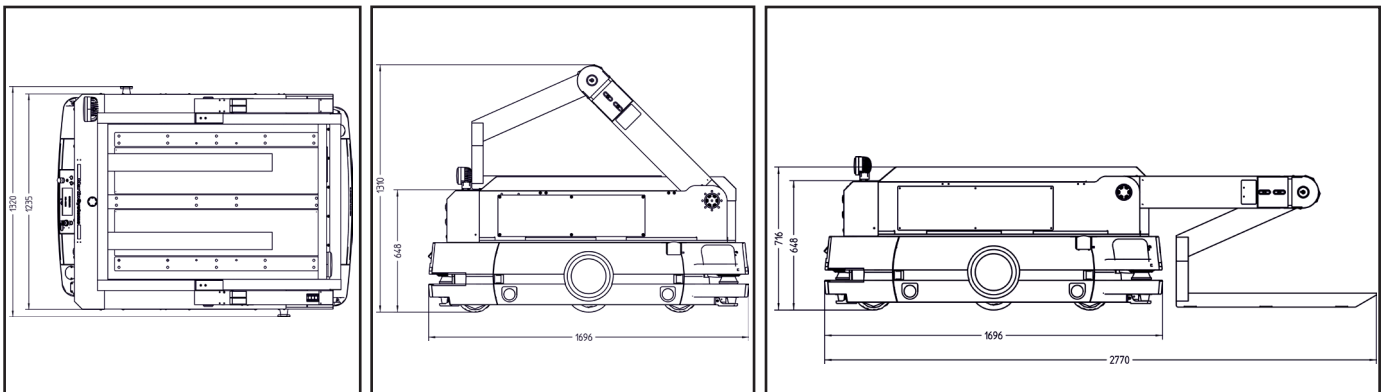

All data are approximate and can vary. Changes are reserved.