



Andreas Traberg
Managing Director
Tel.: +45 31 32 87 43
a.traberg@interroll.com



Stefano Amarena
Solution Sales Director
Manufacturing Logistic
Tel.: +39 370 3348016
s.amarena@interroll.com



Kenneth Martlev
Key Account Manager
Tel. +45 22 16 02 58
k.martlev@interroll.com



Henning Wacher
Application Engineer,
Tel.: +45 36 88 33 54
h.wacher@interroll.com



LCP AMR TOP MODULE

Interroll

Leading global provider for material handling solutions

28,000
customers



2,500
employees

35
companies

Founded in
1959

16
main factories



Headquarters in
Switzerland

Interroll

Focus on growth markets

Food & Beverage



Warehousing & Distribution

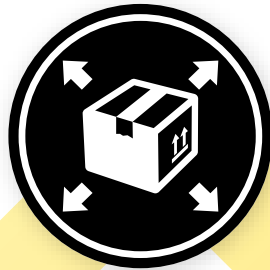

Courier, Express & Parcel



Fashion & Retail



Airports



Tire & Automotive



Supermarket Solutions



Industrial Manufacturing

Momentum for growth

Interroll product areas

Key Figures for the Interroll Group (2022)

CHF 664.4 Mio. Sales

CHF 572.6 Mio. Order Intake

CHF 105.2 Mio. EBIT



Distribution of order intake



8.5%

Pallet Handling

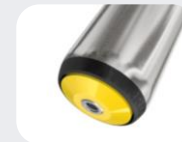

19.4%

Rollers



40.5%

Conveyors & Sorters



31.6%

Drives

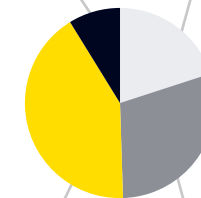

LCP AMR
TOP MODULE



LCP AMR TOP MODULE

Interroll Solution

Two modules – one construction

INTERROLL

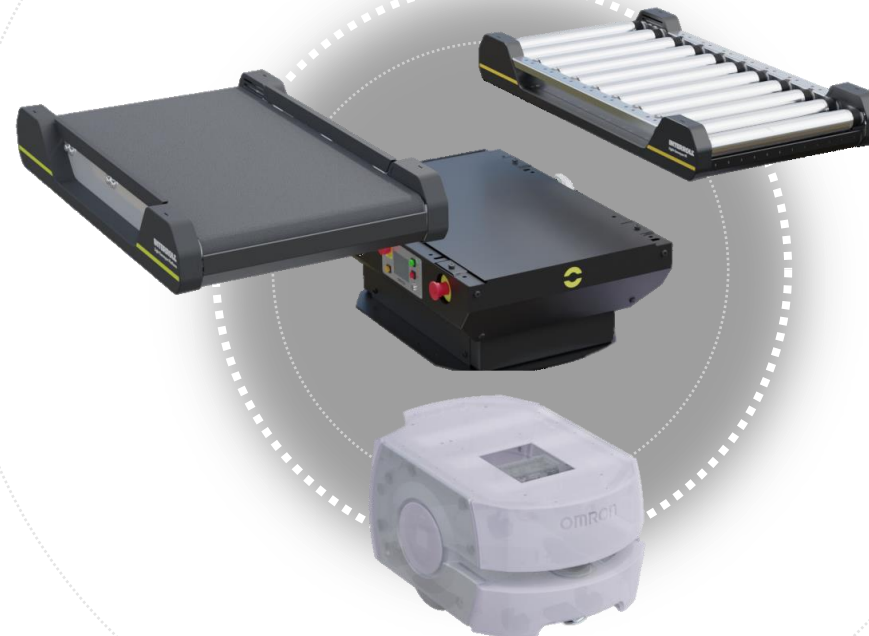

OMRON



Modular

Belt drive and & Roller-bed conveyor in two dimensions



Ease of integration

Unique design, for seamless merge with OMRON



Platform concept

Design line look and feel identical to Interroll LCP Light Conveyor Platform



LCP AMR TOP MODULE

Interroll Solution

INTERROLL

Light Conveyor Platform: Stationary Conveyors

All included when you buy a Interroll LCP conveyor



Photo Sensors
Build in in both end of the conveyor and connected to the control

Side Guide
In 3 different configurations
Included adjustable

Conveyor frame
In galvanised material and painted leg system

Side Cover
For protecting belt adjustment and housing electrical connectors for extension modules

Conveyor belts
Available in 4 variants
Including ESD for electronic production

Leg system
In different heights and adjustable both in angle and height

Power connection
for 3 x 400VAC 50 Hz or 3 x 480VAC 60Hz

Cable channels
Build into the conveyor frame
With separation of signal and power cables

Motor Control
With display and build-in safety system

Plug & Play” solution
CE-marked Stand-alone conveyor, with integrated Emergency Stop Button

Versatility made easy
Length: 1, 2 & 3 meters
Widths: 320, 420 & 620
Weight: up to 50 kg

Platform concept
Daisy-chain conveyors, to create tailor-made conveyor system

LCP AMR TOP MODULE

The versatility of the design

Multipurpose design



Dimensions

Two frame sizes (420x800 & 620x1000) designed to fit to LCP dimensions

Conveyor

Both belt and roller conveyor designed for both frame sizes

Can be ESD configured

The belt top comes as standard with PVC belt, but can be upgraded with ESD belt

LCP AMR TOP MODULE

ESD LCP configuration

Electro Static Discharge ESD LCP configuration

- Light Conveyor Platform (LCP) - the Electro Static Discharge (ESD) feature, specifically designed for the electronics industry. This new feature is a game-changer for those who are looking for a reliable and efficient way to handle sensitive electronic components during production and assembly.
- The ESD feature on the LCP has been rigorously tested and conforms to the electrical surface resistance (ROB) requirements of less than 3×10^8 Ohm and electrical volume resistance (RD) requirements measured according to ISO 21178 – section 6.1, which is lower than 10^9 Ohm.



ESD Compliance Report



Date:	2022-10-13		
Company:	Interroll Joki A/S		
Address:	Hammerholmen 2-6, DK-2650 Hvidovre		
ESD coordinator:	Jan Støvring Jensen	Email:	j.jensen@interroll.com
ZENITECH.dk Auditor:	Claus Hillker	Email:	ch@zenitech.dk

ZENITECH.dk
Albuen 42, DK 6000 Kolding · +45 9617 0818 · info@zenitech.dk · www.zenitech.dk

LCP AMR TOP MODULE

The communication concept



Integrated communication

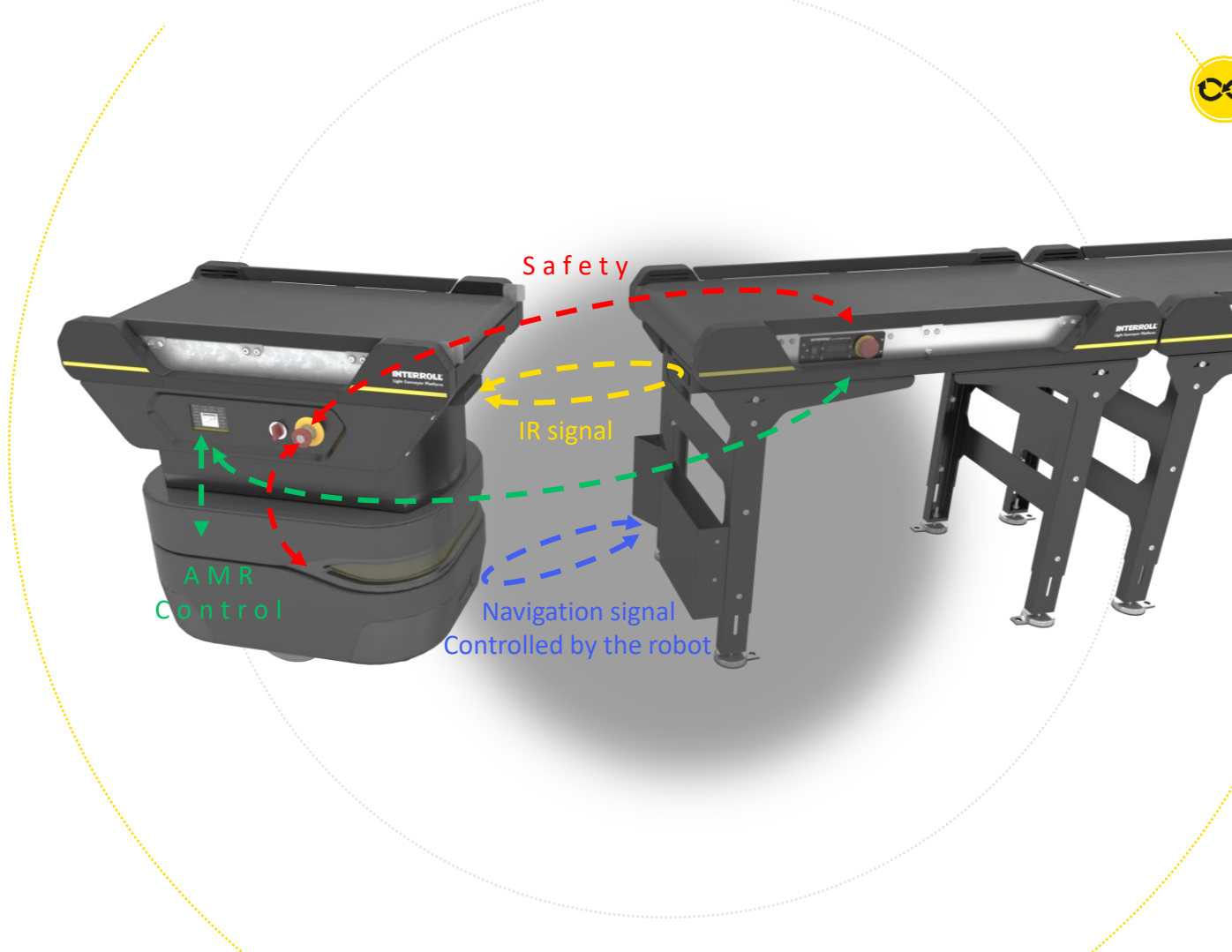

Navigation signal

Navigation plate installed on LCP, which enable the robot to navigate in place



Wireless communication

Infrared modules ensure seamless communication between stationary and mobile units



AMR control

Controls integration between LCP, Robot and AMR Top-Module



Safety

Both stationary and mobile conveyors units are formed as one safety unit

LCP AMR TOP MODULE

AMR top will as a start be produced in Denmark

Production in Denmark – But potential to localize

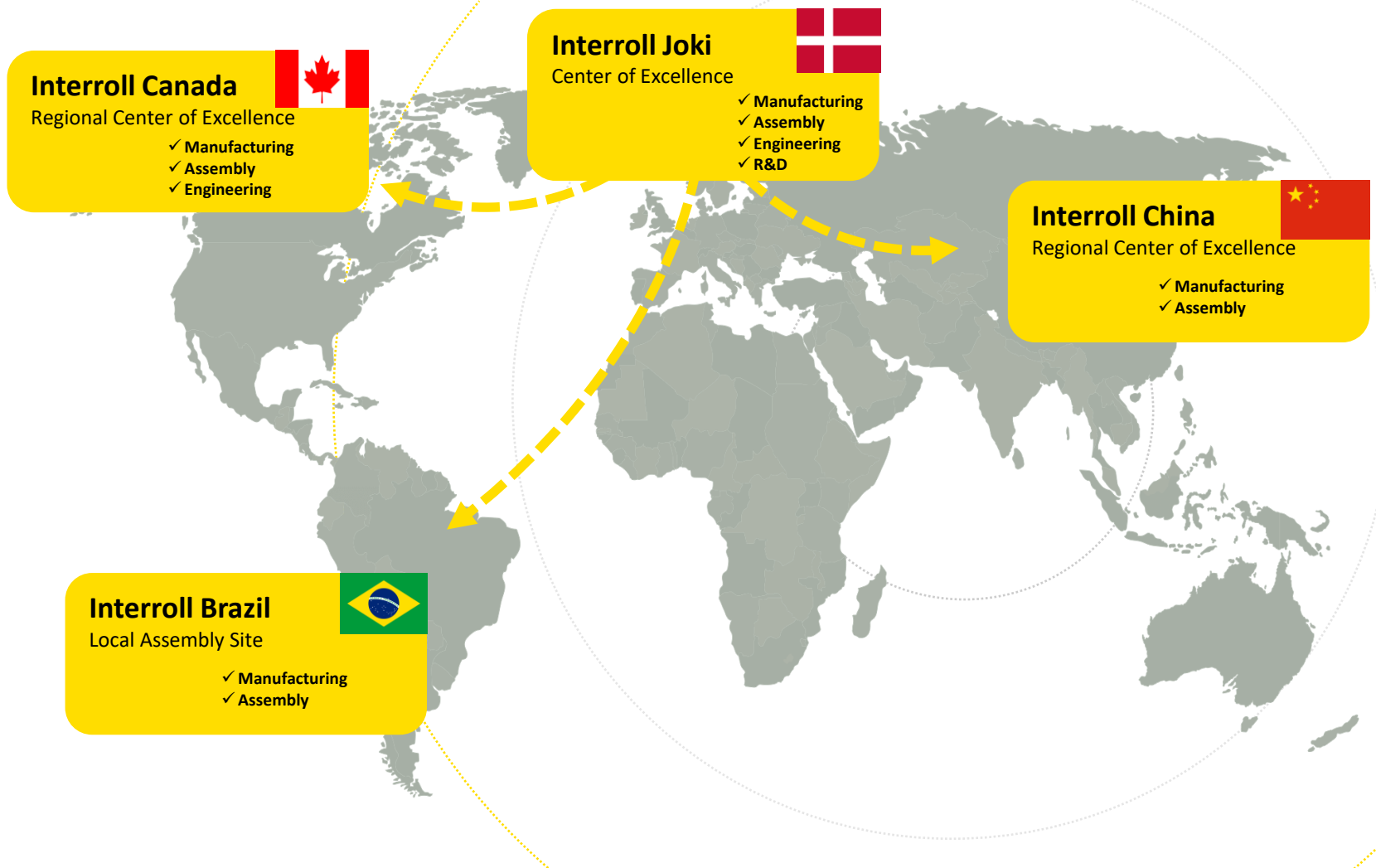

Center of Excellence

Acts as Lead plant, responsible for design and product management
Responsible for localization cascade, which is volume dependent



Regional Center of Excellences

Regional Centers of Excellence acts a local production, mirroring processes and quality from Center of Excellence



Local Assembly

Local assembly can be included in manufacturing cascade.

LCP AMR TOP MODULE

Interroll Sales strategy – Always via System integrators

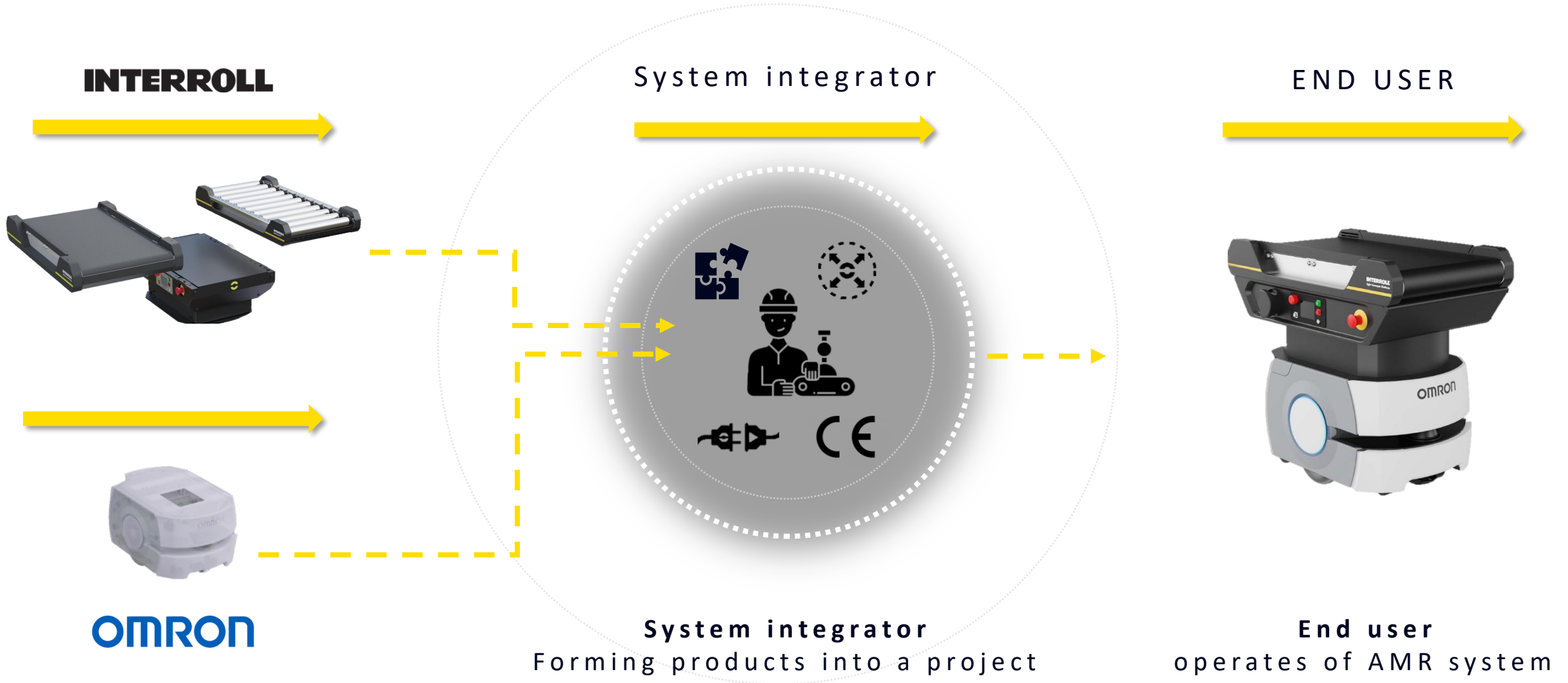

LCP AMR TOP MODULE

Service Concept

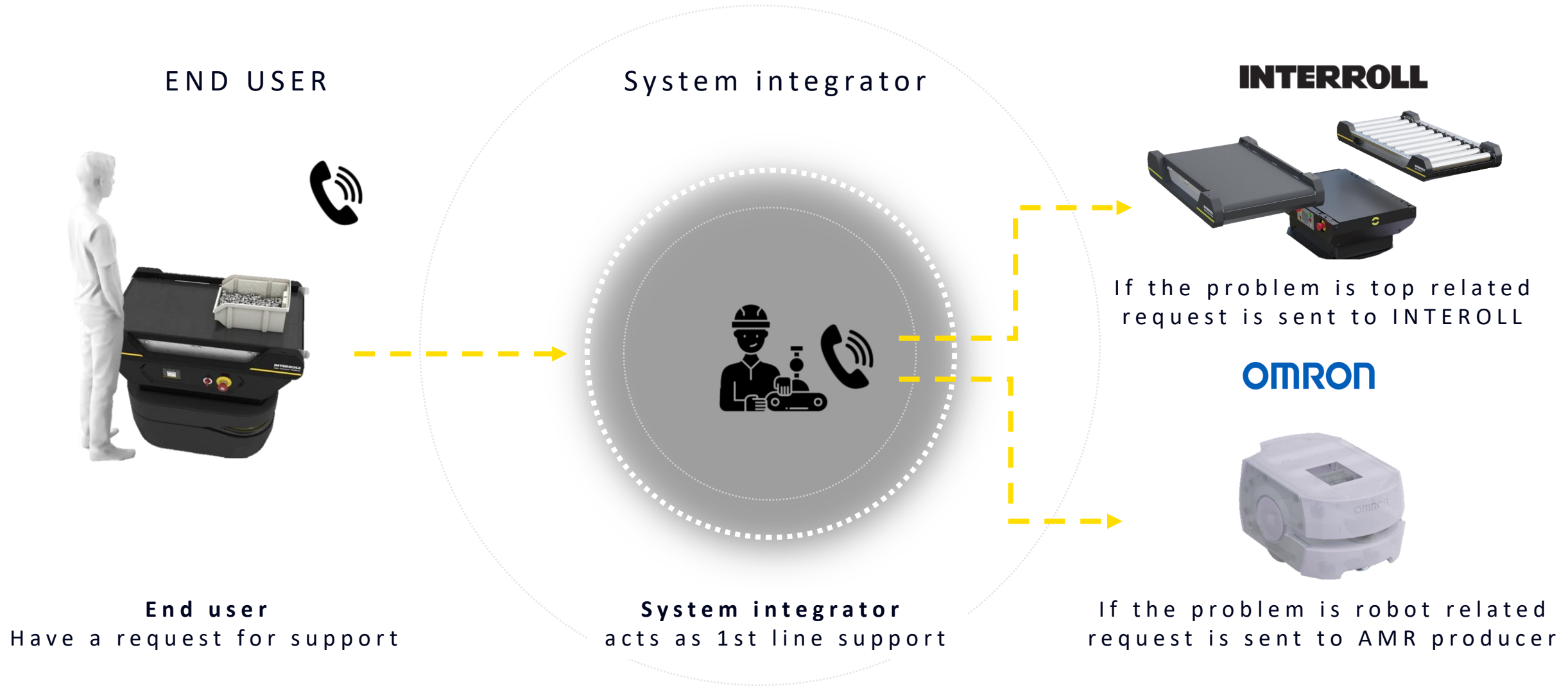

LCP AMR TOP MODULE

AMR Top: Strategic Partnerships - Trust matters

OMRON

Solution Partners

OMRON Solution Partners are a group of engineering companies that collaborate with OMRON in order to complement OMRON product with solutions to cover the demand for any kind of Industry.

INTERROLL



Rolling on Interroll

A strategic asset

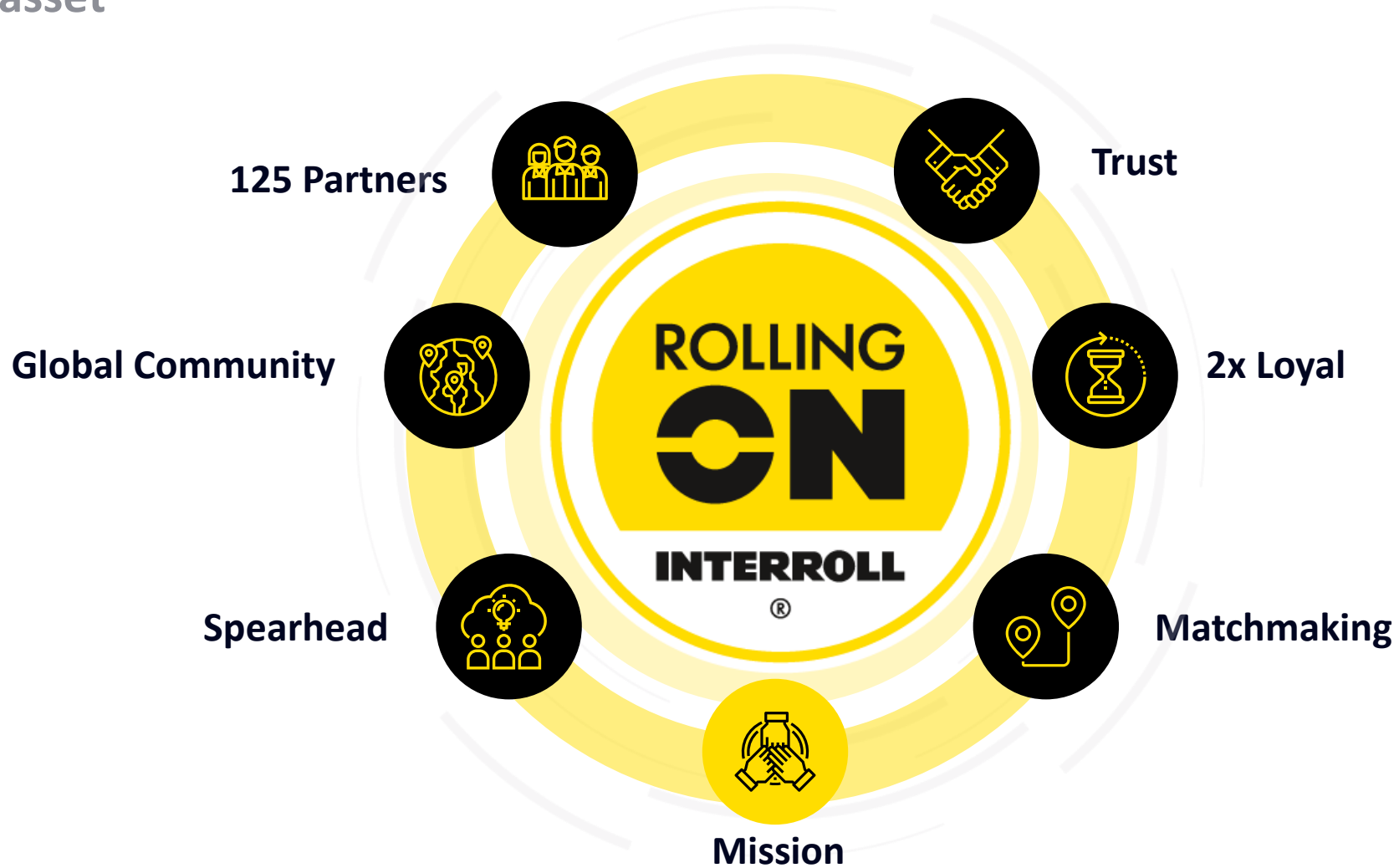

We help passionate business leaders of SMEs* to bring value to local markets

*Small and medium-sized enterprises





LCP AMR TOP MODULE

Marketing Material



Web

- Technical data sheets

Interroll LCP Mobile Robot Platform	
Mobile robot components 	Width: 420 mm LCP AMR Top-Module S-Platform with: <ul style="list-style-type: none"> • Adapter module for mobile robot • Conveyor module (l=800mm/W=420mm) • AMR control • Built in safety system • Wireless communication module • Fixed side guides Mobile module standard belt conveyor configuration
	Interroll adapter with cabling for OMRON LD60 and LD90 robot Mobile module ESD conveyor configuration
	Interroll adapter with cabling for OMRON LD60 and LD90 robot Mobile module with roller conveyor
	Interroll adapter with cabling for OMRON LD60 and LD90 robot
	Width: 620 mm LCP AMR Top-Module M-Platform with: <ul style="list-style-type: none"> • Adapter module for mobile robot • Conveyor module (l=1.000mm/W=620mm) • AMR control • Built in safety system • Wireless communication module • Fixed side guides Mobile module standard belt conveyor configuration Interroll adapter with cabling for MIR250 robot Interroll adapter with cabling for OMRON LD250 robot Mobile module ESD conveyor configuration Interroll adapter with cabling for MIR250 robot Interroll adapter with cabling for OMRON LD250 robot Mobile module with roller conveyor Interroll adapter with cabling for MIR250 robot Interroll adapter with cabling for OMRON LD250 robot

- Interroll Homepage

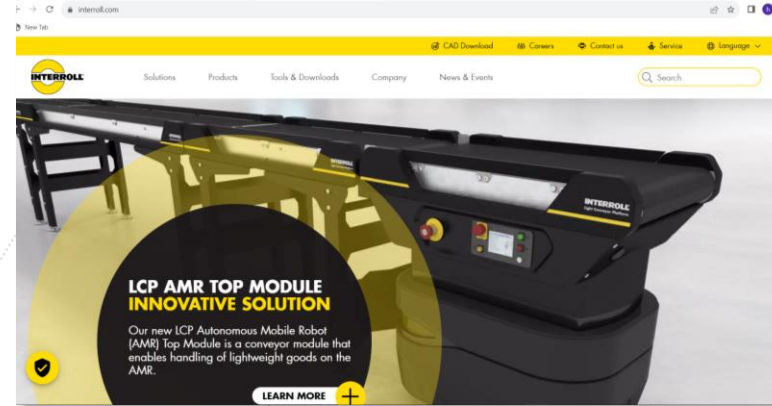

- Animations



- Videos



- Interroll presentations

Interroll
Leading global provider for material handling solutions

28,000
customers



2,500
employees

35
companies

Founded in
1959

16
main factories

 Headquarters in Switzerland

2 LCP AMR TOP MODULE 2023 © Interroll Group INTERROLL INTERROLL

LCP AMR TOP MODULE

Interroll Solution

Unique buying reasons for LCP AMR Top Module

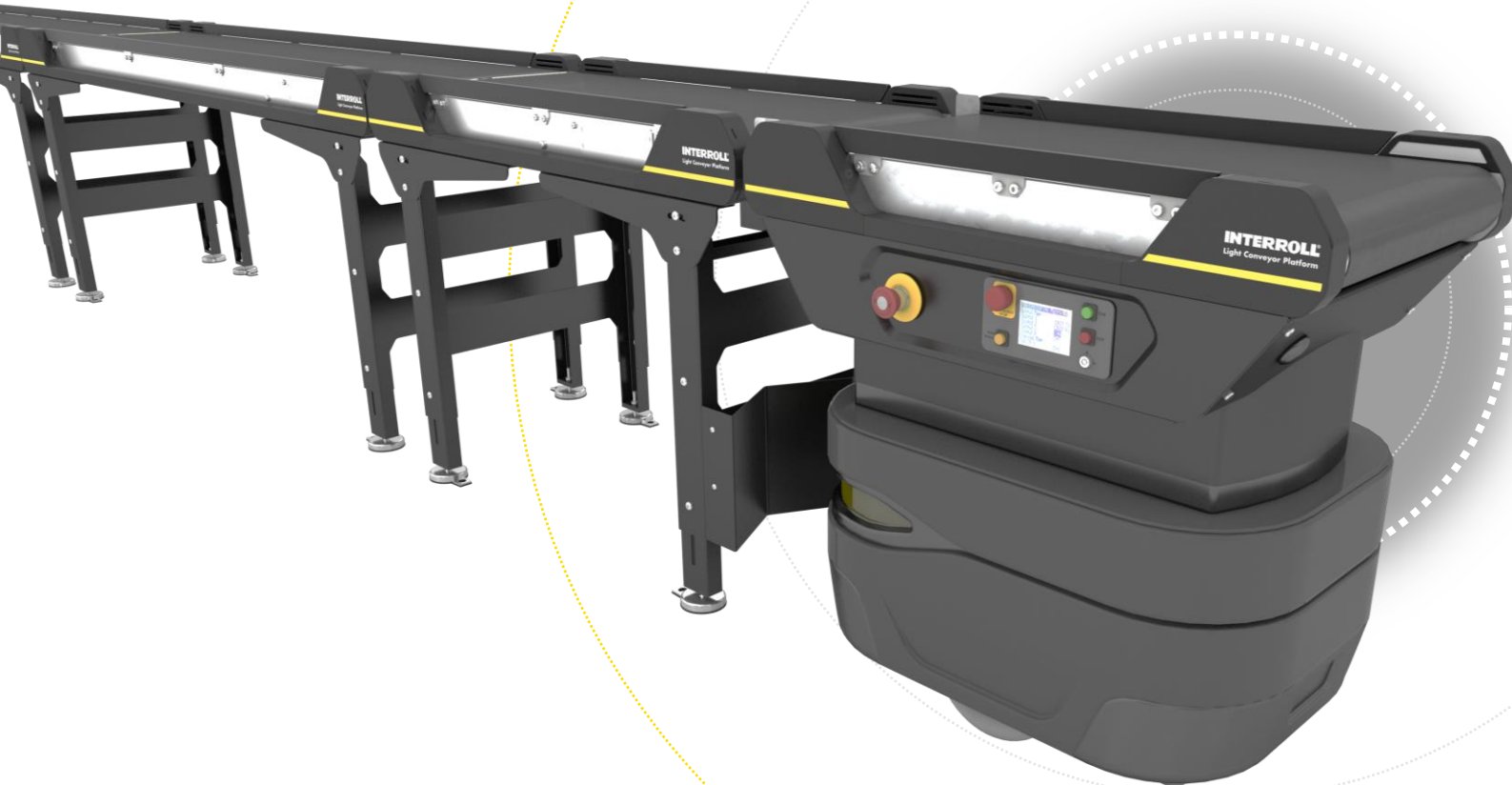

Full-Solution

Complete platform, including top module, stationary conveyors and communication interface.



Tested & Approved

Developed with focus on ease of integration

How can we help you?



Andreas Traberg
 Managing Director
 Tel.: +45 31 32 87 43
a.traberg@interroll.com



Stefano Amarena
 Solution Sales Director
 Manufacturing Logistic
 Tel.: +39 370 3348016
s.amarena@interroll.com



Kenneth Martlev
 Key Account Manager
 Tel. +45 22 16 02 58
k.martlev@interroll.com



Henning Wacher
 Application Engineer,
 Tel.: +45 36 88 33 54
h.wacher@interroll.com



LCP AMR
TOP MODULE