

Hardware Specifications

Model		IP-3000M	IP-3000SL	IP-3000L	IP-3000XL
Inspection PCB	Minimum size	50 × 50mm	50 × 50mm	50 × 50mm	50 × 50mm
	Maximum size	330 × 250mm	450 × 300mm	510 × 460mm	610 × 510mm
	PCB thickness	0.5 ~ 5.0mm			
System	Product height	35mm	35mm	50mm	50mm
	Dimensions	W644 × H592 × D716	W774 × H592 × D821	W912 × H634 × D1109	W1030 × H661 × D1230
	Weight	60kg	75kg	90kg	120kg
	Illumination	Fluorescent light			
	Power supply	AC100V ~ 240V			
	Power consumption	220 W			300W
	Repeated positional precision	± 0.05mm or less			
	Camera travel speed	560mm/sec			
	Operating environment	Temperature : 15 ~ 35°C Humidity : 20% ~ 80%			
	System OS	Windows XP or Windows 7			
Standard furnishings	Controller PC / Monitor				
	Fault point laser marking function				
	Inspection PCB top locking function				
Options	Operator box				
	Fault message printer				
	Area sensor				
	One dimensional, two dimensional barcode reading function				
	Repair terminal "Repair Pro"				

Software Specifications

Standard furnishings	Priority visual inspecting function	
	Inspection program creating function (Automatic PCB imaging • Optional point inspecting function)	
	Photographing function	
	Program learning function	
	Illumination brightness adjusting function	
	Scale gauge displaying function	
	Critical NG warning function	
	Parts drawing function	
	Customized fault category displaying and judging function	
	Automatic maintaining function	
	Inspection result and NG image displaying function	
	Options	Automatic appearance inspection system linking software
		Mount / CAD data linking software

Exterior dimension (Front view)

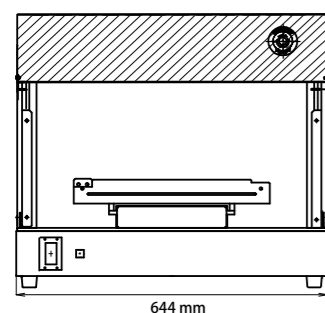

644 mm

Standard type(Side view)

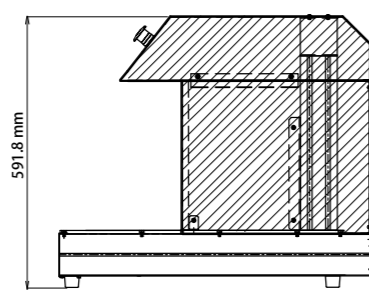

591.8 mm

Area sensor attached type(Side view)

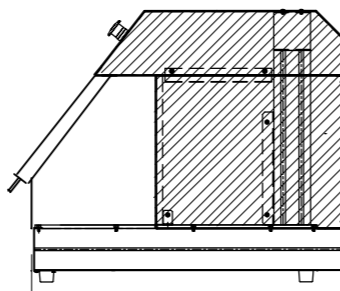

677.4 mm

Area sensor is available as an option.

WIT Co.,Ltd.

Head Office 8-1-5 Minaminagareyama, Nagareyama City,
Chiba-Pref., Japan 270-0163
Tel. +81-4-7140-6085 Fax. +81-4-7140-6086



<http://www.witjpn.com>

<Locations>

China Shanghai Office Tel. +86-21-65535500 Fax. +86-21-65527706
China Shenzhen Office Tel. +86-755-83461500 Fax. +86-755-83461639
Thailand Bangkok Office Tel. +66-2237-2479 Fax. +66-2233-9108

The specifications and appearance of the products in this brochure are subject to change for improvement without notice.
Printed in March 2012

Inspection **Pro**

Innovation in Circuit Board
Inspection Creates New Value



Inspection **Pro**
IP-3000

New Way to Conduct Visual Inspections
Visual Inspection System

Three Features

1 Reliability

Eliminates Visual Inspection Omissions

2 Traceability

Real-time Control without Missing Defective Images and Repair Images

3 Testability

Achieves Inspection Efficiency through Integrated Appearance and Electrical Inspections

WIT Co.,Ltd.

Circuit Board Inspection Accurately Detects All Manufacturing Defects

Nearly all of the circuit boards manufactured around the world are inspected by automated testing equipment (ATE), such as automated optical inspection (AOI) equipment, automated X-ray inspection (AXI) equipment, or in-circuit testers (ICT), and then people conduct visual inspections to identify manufacturing defects based on the inspection results output by the automated testing equipment.

Needless to say, it is very difficult to use visual inspection to identify defects in today's circuit boards, which are densely mounted with a great number of very small components. The IP-3000 proposes new way to eliminate the elements of uncertainty, such as the visual inspector's experience, ability, and environmental conditions, to accurately and quickly detect all of the manufacturing defects in the inspected circuit board.

Features Development Concept

Achieving reliability has been an issue for visual inspections, so we made that the product development concept for the initial development. We later expanded the concept to traceability by focusing on the inspections and repair result images acquired by the IP-3000 and then on achieving testability by focusing on visual inspection flexibility.

1 Reliability

Inspection equipment that makes possible instant and accurate visual judgment without omissions is the basic concept of the IP-3000. Unlike conventional visual inspection where the entire inspected circuit board is viewed, the inspection is narrowed down to the points that need to be viewed and is accurately performed without any omissions.

2 Traceability

It is well known that automated inspection equipment, such as AOI, AXI, and ICT, detect defective circuit boards, but what often goes overlooked is that most of the areas with manufacturing defects are found manually using a visual inspection. The IP-3000 is used in the repair process to record and manage the defective and repair images to achieve true traceability.

3 Testability

Programs can be registered in advance in the IP-3000 for areas that are difficult to inspect using AOI or AXI to achieve a perfect manufacturing process inspection without omissions through the combined used of AOI, AXI, and IP-3000. Further, we want to optimize the inspection process and make it more efficient from an overall perspective including such electrical inspections as ICT and FCT. Taking this cross-sectional perspective from circuit board mounting to final quality assurance while focusing on EMS operations, which in recent years have been specialized for mounted circuit board manufacturing, allows us to offer new solutions that reduce manufacturing and inspection costs and shorten the production preparation period.

Hardware

IP-3000 is equipped with a newly developed high magnification camera which enables the visual inspection of very small components such as 0603 or 0402. Checking all visual inspection areas without omissions requires ultra high speed movement of the camera head. The camera head contains two high-performance cameras; a top camera and a angled camera with different magnifications. For each item to be inspected, the previously set conditions, such as the angle (select top or slanted at a 45° angle and the camera turns in the 360° degree direction), image magnification, illuminance, etc., are followed and the image is projected on the monitor.

But no matter how excellent the hardware is, it is not possible to conduct an effective visual inspection if the visual inspector cannot instantly operate it as desired. For this reason, the IP-3000 is equipped with point movement and swing functions (Photo ②) as well as other excellent functions.

The equipment is operated using a mouse and keyboard or a special console box. When a defect is found, a laser pointer is used to indicate the defect area on the inspected circuit board and display it so that repairs can be made at that time. If repairs will be made in batch during a downstream process, the required defect information is displayed in batch to the repair person using a Repair terminal "Repair Pro" (optional).

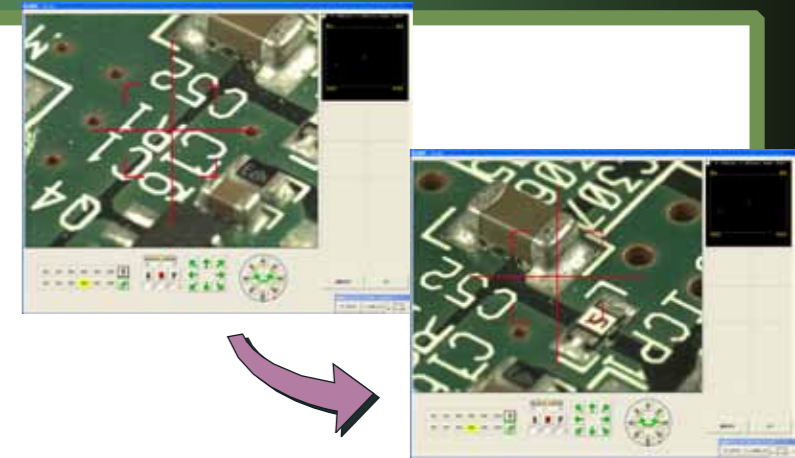
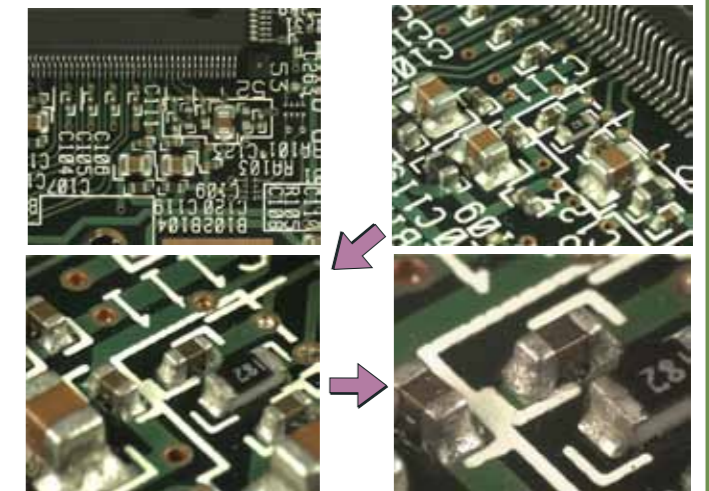

photo ① Point Movement

You can use the mouse to freely click on a point displayed on the screen. That camera will move to that point.



High Magnification Camera

In the standard configuration, the unit is equipped with 2 cameras (1 top, 1 angled) and the magnification can be changed to match the size of the component. A high magnification camera can also be installed as an option (Photo ②).

Inspection Program

Inspection program creation is possible if you prepare for a mounted circuit board that will be inspected (CAD data, etc., is also acceptable).

The inspection program is completed by identifying the areas that need to be visually inspected from the mounted circuit board image photographed by the IP-3000 and then sets to camera to make it easy to look for defects. In addition, if the QFP or connector leads, etc., will be inspected, zone programming can be used to instantly create a batch program, and the high-quality images can also be easily registered.



Good Quality Image Display Function

AOI Link

The IP-3000 follows the automated optical inspection equipment inspection results and follows up in order on the areas diagnosed as being defective by displaying the image of that area under the optimal conditions to provide the visual inspector with an environment for making a correct determination. In addition, after the visual inspection of the areas diagnosed as being defective is completed, it is followed by a visual inspection of the important areas previously registered in the program. Therefore, the IP-3000 can be used to conduct all the visual inspections in batch to make operations more efficient and reduce the labor requirements.